

How to facilitate comparability among product models: applying a standardizing description approach

Lukas Paehler[✉] and Sven Matthiesen

IPEK - Institute of Product Engineering at Karlsruhe Institute of Technology, Germany

[✉] lukas.paehler@kit.edu

Abstract

During a design process, designers are supported by several purposive product models. To enable designers to switch between them, researchers need to consider the linking of product models during their development. To assist researchers in doing so, the capabilities of a standardizing description approach, stances towards product models, was investigated. The results show that the description approach was able to identify indicators of linking possibilities by facilitating comparability. This is a step towards assisting researchers in considering the linking of product models systematically.

Keywords: design models, engineering design, model-based engineering (MBE), design research

1. Introduction

In engineering design, models of a product are essential tools for designers to describe, visualize, and shape thoughts for themselves or to communicate with others (e.g., Buur and Andreasen, 1989; Maier *et al.*, 2014). These product models may represent different aspects of technical systems (Hubka and Eder, 1990), address different purposes (Buur and Andreasen, 1989), or exist in different mediums (Jones *et al.*, 2020) throughout a design process. A design process requires different product models because all models are limited in their capabilities (Maier *et al.*, 2014) and no model can cover all use cases. Therefore, a sequence of product models is created through a design process (Andreasen, 1994), which requires switching between these product models. Switching enables designers to select a product model appropriate for the point in time and situation (Jones *et al.*, 2020). For example, Grauberger *et al.* (2020) addressed the switching between two product models in the use case of robustness evaluation. They linked the Contact and Channel Model (C&C²-M) (based on Matthiesen *et al.*, 2019b), which focuses on embodiment-function relationships, and the Tolerance Graph (based on Goetz *et al.*, 2018), which focuses on robustness evaluation. Thereby, this link enables the efficient combination of two models for an improved early robustness evaluation. Hence, product models are essential tools for designers and should be linked to each other by researchers to enable the efficient use of the right models, at the right time, and in the right situation in a design process.

The possibilities for linking product models are considered during the development or advancement of a product model or are identified in retrospect when comparing different product models. In both cases, the identification of linking possibilities relies on the descriptions of the product models and the ability of researchers to understand the descriptions properly. But product model descriptions lack a commonly applied structure and vocabulary. This can be illustrated by comparing the description of the Design Structure Matrix (DSM) by Palani Rajan *et al.* (2005) with that of Alizon *et al.* (2007). They describe different aspects of the DSM, structure these aspects differently, and use different vocabularies to refer to the described aspects (Paehler *et al.*, 2023). In contrast, a common vocabulary reflects a shared

understanding within a domain (Gruber, 1993) and counteracts ambiguity (Štorga *et al.*, 2010). Thereby, the ability to describe product models using a shared understanding and without ambiguity affects the identification of linking possibilities. It is therefore necessary to describe product models in such a comparable, standardized way that linking possibilities can be identified, so that researchers can take them into account in model development and provide designers with the appropriate knowledge for model selection and use.

Different approaches to describing multiple product models in a comparable way can be distinguished in the current state of research.

- Weidmann *et al.* (2017) and Matthiesen *et al.* (2019a) categorized product models in retrospect based on predefined categories and their possible values. Examples of categories used by Weidmann *et al.* (2017) are the discipline of use, type of depiction, and the type of information. These were partly adopted by Matthiesen *et al.* (2019a). Still, they pursued different aims. While Weidmann *et al.* (2017) used categorization to investigate the interdisciplinary character of product models in retrospect, Matthiesen *et al.* (2019a) aimed at their methodical selection.
- Buur and Andreasen (1989) and Paehler *et al.* (2023) focused on defining and structuring fundamental concepts when developing and discussing product models or the modelling activity. An example of such a concept used by both is the purpose of modelling. Buur and Andreasen (1989) applied the concepts to derive the need to develop new models and used the concepts to characterise them. In comparison, Paehler *et al.* (2023) understood the defined concepts as a means for discourse among researchers when developing or handling models with the aim of facilitating comparability, avoiding misunderstandings, and identifying commonalities, while mentioning the linking of product models as a sub-goal.
- Eisenbart *et al.* (2011) and Kohn (2014) provided frameworks that aim to establish a common ground for information about product models. Eisenbart *et al.* (2011) built their framework around the basic idea of design states which resemble similar information, with the aim of comparing product models within the design states across disciplines. In contrast, Kohn (2014) was guided by the idea of being able to bring together extensive knowledge for product model use in practice and thereby support designers in their work with product models. Both of them picked up elements of the previously described approaches.

Of these approaches, only Paehler *et al.*'s (2023) approach is aimed at researchers, focusses the development and advancement of models, and explicitly mentions the linking of different product models as an aim. This approach consists of a *classification-oriented*, a *functionality-oriented*, and a *message-oriented stance* towards product models. However, the problem is that it is not known whether or how these stances in fact facilitate the identification of linking possibilities between different product models in engineering design research.

To solve the above mentioned problem, this article investigates the systematic comparison of product models with respect to their potential for linkage with other product models based on the stances of Paehler *et al.* (2023). To this end, the research question is: *To what extent can the stances towards product models be applied to identify commonalities between different product models in engineering design in terms of their potential for linking with each other?* The answer to this research question will allow conclusions to be drawn about the suitability of the description approach for the targeted identification of linking possibilities between product models. This will be a basis for further research into the efficient combination of different product models within a design process.

2. Materials and methods

To answer the research question, the following scenario was considered: An existing technical system was to be analysed in terms of its working mechanism through the use of product models. During this analysis, several product models needed to be built to cover the different aspects of the technical system. As the relevant aspects were spread over the product models, these had to be considered in conjunction with each other for the analysis which would benefit from linking the models. Therefore, the product models built on the basis of this scenario could be used to evaluate the contribution of the stances to the identification of linking possibilities.

For use in the scenario, an angle grinder was selected as a technical system. The angle grinder and its representation are introduced in Section 2.1. The procedure from the representation of the angle grinder to answering the research question was as follows:

1. Three product models were built that could be used to analyse the angle grinder. These were a DSM, a Function Structure, and a C&C²-M. The models are briefly introduced and their selection described in Section 2.2.
2. All product models built were subsequently translated into the stances on product models according to Paehler *et al.* (2023). The stances are introduced in Section 2.3.
3. In the end, the stances of the product models were compared and evaluated with regard to the identification of linking possibilities to answer the research question.

2.1. The technical system

The drive train of a Fein WSG 8-125 angle grinder was considered. An angle grinder is a power tool consisting of an exchangeable tool attached to a hand-held machine. It is used to cut or grind workpieces, depending on the tool being used. The exchangeable tool is flat and round, for instance, a grinding wheel, and is rotated at high speed. The axis of rotation of the tool is perpendicular to the main axis of the handle. This technical system was chosen for the following reasons:

- **Combination of disciplines:** The interaction of mechanical and electrical components is a realistic requirement regarding the capabilities of product models and their interdisciplinary nature when used in today's design processes.
- **System complexity:** The behaviour of the system, e.g., with regard to the resulting vibrations, is influenced by a large number of relevant parameters and their interactions (Sturm *et al.*, 2020), which must be represented for an analysis of the technical system.
- **System dimensions:** The dimensions of the technical system and the number of components are of a manageable scale in the context of this explorative investigation.

Figure 1 shows an exploded view of the technical system. This view was used as a starting point for the building of all product models to exclude any influences due to different initial design representations.

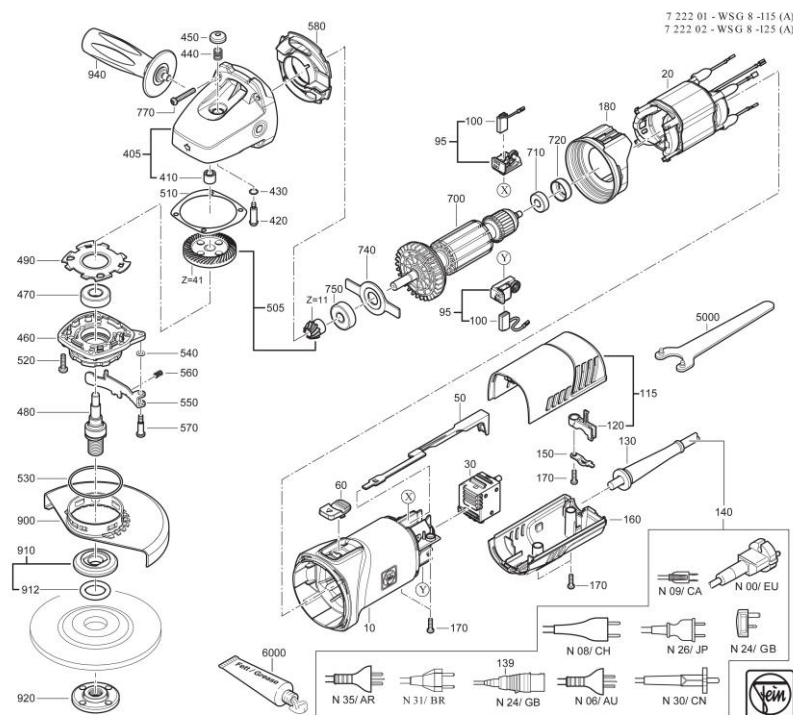

Figure 1. Exploded view of the technical system under consideration, a Fein WSG 8-125 angle grinder (C. & E. Fein Service GmbH, 2023)

2.2. The product models being built

The product models chosen as examples for this study were the DSM as described by Browning (2001), Function Structure as described by Pahl *et al.* (1996), and C&C²-M as described by Matthiesen *et al.* (2018). These product models were chosen because they all represent different aspects of the technical system, can be used simultaneously in a design process, and are used for different purposes. Further, they are all abstract product models, as the abstract character is expected to present a greater demand for the description approach. As such, they represent a sample group of product models where frequent and rapid switching may occur in the application and are therefore particularly suitable for this investigation.

The DSM, more specifically the component-based DSM, is a representation and analysis tool which displays the relationships between components as a square matrix on the level of decomposition of a technical system (Browning, 2001) (for an example, see Figure 2). The Function Structure depicts the sub-functions and their interactions as well as the type of interaction when interplaying to achieve the overall function as a block diagram, being independent of a certain solution (Pahl *et al.*, 1996) (for an example, see Figure 3). The C&C²-M explicitly represents the relationships between embodiment and function by employing abstracting model elements and application rules and is intended for the analysis of existing technical systems as well as the development of new solutions (Matthiesen *et al.*, 2018) (for an example, see Figure 4). Please refer to the original product model references for more information.

2.3. The applied description approach

The product model stances according to Paehler *et al.* (2023) were developed for describing product models in engineering design research with the aim of facilitating comparability, avoiding misunderstandings and identifying commonalities with the state of research, thereby also supporting the linking of different product models. There are three stances, with each stance containing a vocabulary for a set of related concepts within a contextual structure, representing a particular stance towards product models for their development and advancement. The stances are as follows:

- The *classification-oriented stance* looks at product models in terms of how they contribute to a design process. This is done by considering the *collective purpose*, which describes the basic operation of the designer that the model is intended to address; the *individual purpose*, which specifies the tangible reason for use in a particular design process; *attributes* that differentiate a product model from other models; and the *core idea*, which embodies the underlying mechanism of action of the model.
- The *functionality-oriented stance* regards product models in terms of their use as target-oriented tools in a design process. This includes the *input* as the initial set of descriptive features used to build the product model; the sequence of actions performed, i.e., the *modelling*; and the *output* as the articulation of information available in the defined modelling language.
- The *message-oriented stance* treats product models as objects carrying attributes of a design, used for communication between designers and/or systems. In this respect, this stance combines the *medium* of the model as the means by which the model is handled in space; the *modelling language* as the way in which data, information or knowledge is present; and the *captured construct*, i.e. data, information or knowledge, retrievable by the recipient of the model.

3. Results and discussion

The results are presented according to the procedure described in Section 2. The product models of the technical system that have been built based on Figure 1 represent the first step and are provided in Figure 2, Figure 3, and Figure 4 on the following page. Applying the description approach resulted in the three stances for each product model. To compare the product models, the resulting stances were sorted by stance. That is, the *classification-oriented stance* of each of the three product models was grouped into one figure, as were the *functionality-oriented* and *message-oriented stance*. In the following subsections, the findings in terms of similar and exactly matching parts of the product model descriptions are discussed separately for each stance. Subsequently the stance-specific findings are consolidated and evaluated to answer the research question.

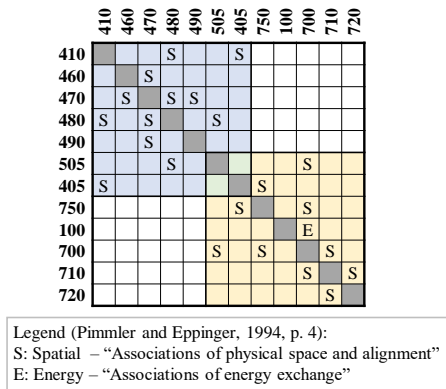

Figure 2. The Design Structure Matrix (DSM) depicts the interactions between the system elements of the angle grinder (colouring corresponds to subsystems; numbering corresponds to the part numbers from Figure 1; built according to Browning (2001); labels of the interactions according to Pimmler and Eppinger (1994))

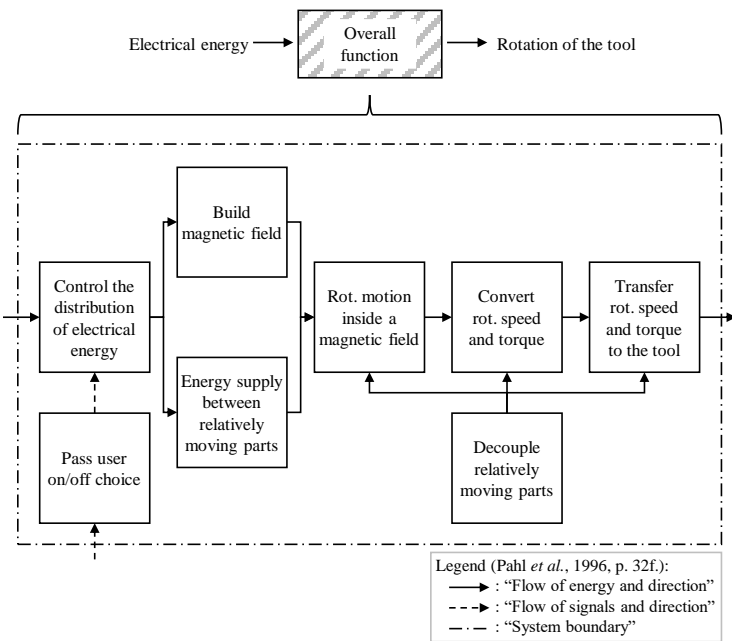

Figure 3. The Function Structure breaks down the overall function of the angle grinder into related sub-functions (built according to Pahl et al. (1996))

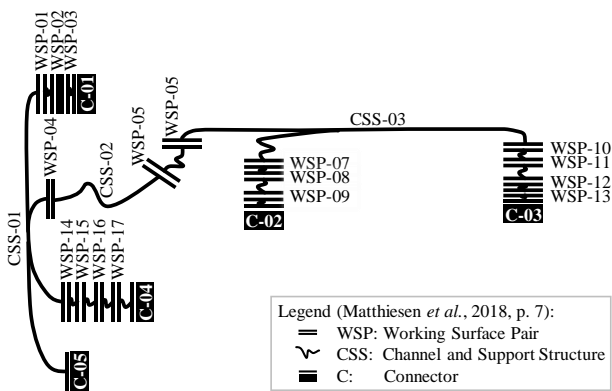

Figure 4. The Contact and Channel Model (C&C²-M) applies defined model elements to depict the working structure of the angle grinder (built according to Matthiesen et al. (2018))

3.1. The classification-oriented stance

Figure 5 provides the resulting *classification-oriented stance* for each product model based on the underlying concepts including marked similar and exactly matching parts. For the concept *collective purpose*, the basic operation of engineering design as stated by Buur and Andreasen (1989) was determined for each model based on the reference used to build it. The concept *individual purpose* was formulated based on the reason for applying each model in the studied case of angle grinder analysis. For the third concept, *attribute*, the classification of product models according to Matthiesen *et al.* (2019a) was referred to. The concept *core idea*, in turn, was derived from the references of the product models by abstraction. Hence, the content of the classification-oriented stance is based on the descriptions of the product models in their references and existing classifications as well as on the scenario in which they were considered.

The comparison between the product models shows matches between the C&C²-M and the Function Structure for the *collective purpose* and between all models for the *attribute*. These matches arise from the re-use of existing classifications or categories, such as in Matthiesen *et al.* (2019a) or Weidmann *et al.* (2017). As such, these matches do not offer new findings, but rather reproduce the current state of research.

Two similarities can also be identified: the *individual purpose* between C&C²-M and DSM and the *core idea* between DSM and Function Structure. In the case of the *individual purpose*, C&C²-M and DSM each establish a relationship between the components or elements of the technical system and the fulfilment of the main function. In the *core idea* of the DSM and Function Structure, a decomposition of an aspect of the system is mentioned. Both of these similarities are due to descriptions that can be found in multiple product models in the literature (e.g., Albers *et al.*, 2019; Eisenbart *et al.*, 2017; Leu *et al.*, 2009). This means that the similarities reflect common elements from the literature and have been confirmed by the comparison.

	C&C ² -Model	Design Structure Matrix	Function Structure
<i>Collective purpose</i>	<u>Describe</u>	Arrange	<u>Describe</u>
<i>Individual purpose</i>	Analyze how the embodiment of <u>components of the angle grinder contribute to its main function</u>	Providing a reduced view of the interaction patterns <u>between the elements of the angle grinder that are relevant for the function fulfilment</u>	Representation of the interaction of the sub-functions to achieve the main function
<i>Attribute</i>	Type of information: <u>function, behavior, qualitative embodiment</u> ; Type of depiction: <u>Graphical</u>	Type of information: <u>function, behavior, qualitative embodiment</u> ; Type of depiction: Table/Matrix	Type of information: <u>function</u> ; Type of depiction: <u>Graphical</u>
<i>Core idea</i>	Three model elements applied based on three basic hypotheses to abstract the embodiment-function relationship.	<u>Decomposition of a system</u> and transformation into a matrix according to a convention	<u>Breaking down the main function of a system into the sub-functions</u> which are connected to each other by defined types of relationships

Figure 5. Overview of the resulting classification-oriented stances (matches marked in orange; similarities marked in blue)

3.2. The functionality-oriented stance

Figure 6 provides the resulting *functionality-oriented stance* for each product model based on the underlying concepts including marked similar and exactly matching parts. The *input* resulted from the chosen procedure of this study, in which the explosion view of the angle grinder was constant for all models. *Modelling* and *output*, meanwhile, were based on the application of the modelling steps to be performed according to the references of the models and their outcome when applied in the scenario of the angle grinder. Thus, the content of the concepts in this stance originates from a combination of the method described in Section 2 and the product models created from it.

The match between all three product models in the *input* is the explosion view of the angle grinder (see Figure 1), which was consistently used as a starting point in the scenario of this study. Therefore, no conclusions can be drawn from this match, but rather the need for further investigation with different inputs or when developing without an existing product.

When considering *modelling*, a similarity can be seen between the DSM and the Function Structure: both document or specify the relationships between represented aspects of the technical system and the types of these relationships. However, the represented aspects are different. While the DSM relates system elements to each other, the Function Structure relates sub-functions. Thus, this similarity could be detached from the represented aspect of the system, as it is found in the product models themselves, by the description. The relevance of relationships can be found analogously in the fundamentals of technical systems, according to which functions arise through interactions of different elements (Pahl *et al.*, 1996). Meanwhile, in the case of the types of relationships, due to a lack of further specification what types of relationships are meant, it remains open whether these are also similar or if they overlap.

	C&C ² -Model	Design Structure Matrix	Function Structure
<i>Input</i>	Sectional drawing of the angle grinder created from an exploded view (Figure 1)(both virtual)	Exploded view (Figure 1)(virtual)	Main function of the angle grinder (mental), exploded view (Figure 1) (virtual)
<i>Modelling</i>	1. System boundaries defined 2. Force flow traced 3. Contact points of components identified 4. Model elements drawn	1. Enter system elements into a matrix 2. Identify and document interactions between system elements including the type of interaction 3. clustering the matrix	1. Specify the main function 2. Identify subfunctions of the subsystems of the angle grinder 3. Specify the relations between the subfunctions and their type
<i>Output</i>	Contribution of the components to the force flow through the system	Interactions between system elements, the types of interactions, and clusters of system elements	Subfunctions to be fulfilled for the main function and their sequence/relationships

Figure 6. Overview of the resulting functionality-oriented stances (matches marked in orange; similarities marked in blue)

3.3. The message-oriented stance

Figure 7 provides the resulting *message-oriented stance* for each product model based on the underlying concepts including marked similar and exactly matching parts. The medium resulted from the chosen way of working of the modeller. The modelling language, for its part, was derived from its description in the publications that were used as references for the three models. The captured construct came from the constructs actually represented in the product models formed, not from those outlined in the

references of the models, as it may change in different scenarios. Consequently, the descriptions in this stance are based on the way the modeller worked, the references of the models, and the models built. Considering the *medium*, all three product models show a match as they existed virtually. This is due to the preference of the modeller to build all models digital. It would also have been possible to create the models physically. Nevertheless, this match shows that it is possible to create all three models virtually and therefore also to share or manipulate them virtually.

With regard to the *modelling language*, a similarity can be seen between the DSM and the Function Structure. They both represent relationships and also have similarities in the types of relationships that can be represented. While a similarity with regard to the representation of relationships has already been identified in the *functionality-oriented stance*, the types of relationships can be considered in more detail here. In both cases, the types energy and material occur identically, while signal and information can also refer to the same thing. Comparing this with the depiction in the models, however, these relationships and their types are depicted differently. There is therefore a similarity here with regard to the information represented in the modelling languages, even if their depiction differs.

The *captured construct* of the C&C²-M and the function structure show a similarity again, which has already occurred with the *individual purpose*: the reference to the main function of the technical system. Likewise, it can be seen to reflect a common concept regarding product models in general.

	C&C ² -Model	Design Structure Matrix	Function Structure
<i>Medium</i>	<u>Virtual</u>	<u>Virtual</u>	<u>Virtual</u>
<i>Modelling language</i>	Defined model elements (working surface pairs, channel and support structures, connectors) and their interactions	N x N matrix, with each system element on the left and on the top outside, as well as the <u>relations in the matrix, which can be of the type 'spatial', 'energy', 'information', 'material'</u>	Block diagram with functions, auxiliary functions, <u>energy, material, and signal flows between functions</u> , and system boundaries
<i>Captured construct</i>	The influence of the form of the components on the force flow and <u>thus the main function of the system</u>	Structure of the technical system, interactions of groups of system elements, and interfaces between groups	The flow of energy through the angle grinder, the conversion of energy through the sub-functions, and the interaction of the sub-functions <u>to achieve the main function.</u>

Figure 7. Overview of the resulting message-oriented stances (matches marked in orange; similarities marked in blue)

3.4. Evaluation of the capabilities of the description approach

With the exception of the *output*, similarities or matches were identified in each concept of the stances. These were partly induced, partly expected, and partly new findings. Accordingly, the application of the stances systematically integrated existing knowledge from the state of the research and the publications of the product models with the insights of the investigated scenario.

With regard to the identification of linking possibilities, only parts of the similarities and matches found between the product models can be used. Although the *attributes* in the *classification-oriented stance* and the *medium* in *message-oriented stance* are indicators that similar information is available in the same *medium* that can be used for switching, these are too abstract to be able to make a statement regarding the possibility of a link. The strong similarity found in *modelling* and *captured construct* among DSM and Function Structure in terms of the representation of relationships is the clearest indicator of the presence of content that can be exchanged through a link between these product models.

However, this does not answer the question of whether the way in which these relationships exist is suitable for a link. Consequently, individual indicators are present in the form of similarities and matches, but the stances do not manage to merge them or relate them to each other to identify links.

Ultimately, the application of the stances showed that only indicators for potential linkages between product models could be systematically derived. The similarities and matches between the descriptions of the product models were not detailed enough and the relationships within the descriptions were too vague to derive linking possibilities from the descriptions. For new linkage possibilities, the indicators therefore need to be pursued and investigated beyond the stances.

This contribution is limited in that as it did not consider more product models or different users of the description approach. Due to the selection of three product models, it can not be excluded that a larger number of product models would not have resulted in more similarities and matches. Such a larger number would have provided a broader basis for evaluation of the description approach. Further, the transferability of the findings to other product models can not be assessed based on the three investigated models. This limitation should be further investigated by looking at other product models. Furthermore, the product models and their descriptions were built by the same person. Since both the building of the models and their descriptions have degrees of freedom, e.g., the level of detail of the descriptions, an influence of the user can not be excluded. It is therefore unclear to what extent an enlargement of the considered product models or variation of the user would have influenced the findings.

4. Conclusion

In this contribution, the feasibility of using a standardising description approach for product models to identify linking possibilities between them was investigated. It was shown that the used description approach, stances on product models according to Paehler *et al.* (2023), was able to identify indicators for linking possibilities. However, these indicators need further investigation as the description approach did not provide enough details for an assessment of the linking possibilities. This shortcoming could be addressed by extending the stances, methodically combining the individual indications and providing criteria for a link. With this in mind, the application of such a description approach is only a first step towards the systematic identification of linking possibilities and needs to be continued. The further continuation is necessary in order to be able to provide research with more appropriate tools to investigate linking possibilities in the future and thereby to be able to provide designers and developers of design processes in practice with efficiently usable product models.

Acknowledgement

The research described in this manuscript has been funded by the German Research Foundation (DFG) within the project “Research map of models for modelling embodiment and function of technical systems to support linked model usage” (446789859). The support by the German Research Foundation (DFG) is gratefully acknowledged.

References

- Albers, A., Matthiesen, S., Revfi, S., Schönhoff, C., Grauberger, P. and Heimicke, J. (2019), “Agile lightweight design - The extended target weighing approach in ASD - Agile systems design using functional modelling with the C&C2-approach”, *Proceedings of the Design Society: International Conference on Engineering Design*, Vol. 1 No. 1, pp. 2667–2676. <https://doi.org/10.1017/dsi.2019.273>.
- Alizon, F., Shooter, S.B. and Simpson, T.W. (2007), “Improving an existing product family based on commonality/diversity, modularity, and cost”, *Design Studies*, Vol. 28 No. 4, pp. 387–409. <https://doi.org/10.1016/j.destud.2007.01.002>.
- Andreasen, M.M. (1994), “Modelling—The Language of the Designer”, *Journal of Engineering Design*, Vol. 5 No. 2, pp. 103–115. <https://doi.org/10.1080/09544829408907876>.
- Browning, T.R. (2001), “Applying the design structure matrix to system decomposition and integration problems: a review and new directions”, *IEEE Transactions on Engineering Management*, Vol. 48 No. 3, pp. 292–306. <https://doi.org/10.1109/17.946528>.
- Buur, J. and Andreasen, M.M. (1989), “Design models in mechatronic product development”, *Design Studies*, Vol. 10 No. 3, pp. 155–162. [https://doi.org/10.1016/0142-694X\(89\)90033-1](https://doi.org/10.1016/0142-694X(89)90033-1).
- C. & E. Fein Service GmbH (2023), “WSG 8-115 (50/60Hz, 220/230V) - 72220108230”, available at: <https://etk.fein.de/spc/index.php?r=item%2Flist&id=4162> (accessed 12 October 2023).

- Eisenbart, B., Gericke, K. and Blessing, L. (2011), “A framework for comparing design modelling approaches across disciplines”, paper presented at ICED, 15.-19.08.2011, Lyngby/Copenhagen, Denmark.
- Eisenbart, B., Gericke, K. and Blessing, L.T.M. (2017), “Taking a look at the utilisation of function models in interdisciplinary design: insights from ten engineering companies”, *Res Eng Design*, Vol. 28, pp. 299–331. <https://doi.org/10.1007/s00163-016-0242-3>.
- Goetz, S., Schleich, B. and Wartzack, S. (2018), “A new approach to first tolerance evaluations in the conceptual design stage based on tolerance graphs”, *Procedia CIRP*, Vol. 75, pp. 167–172. <https://doi.org/10.1016/j.procir.2018.04.030>.
- Grauberger, P., Goetz, S., Schleich, B., Gwosch, T., Matthiesen, S. and Wartzack, S. (2020), “A CONCEPTUAL MODEL COMBINATION FOR THE UNIFICATION OF DESIGN AND TOLERANCING IN ROBUST DESIGN”, *Proceedings of the Design Society: DESIGN Conference*, Vol. 1, pp. 157–166. <https://doi.org/10.1017/dsd.2020.12>.
- Gruber, T.R. (1993), “A translation approach to portable ontology specifications”, *Knowledge Acquisition*, Vol. 5 No. 2, pp. 199–220. <https://doi.org/10.1006/knac.1993.1008>.
- Hubka, V. and Eder, W.E. (1990), “Design Knowledge: Theory in Support of Practice”, *Journal of Engineering Design*, Vol. 1 No. 1, pp. 97–108. <https://doi.org/10.1080/09544829008901646>.
- Jones, D.E., Snider, C. and Hicks, B. (2020), “A FRAMING OF DESIGN AS PATHWAYS BETWEEN PHYSICAL, VIRTUAL AND COGNITIVE MODELS”, *Proceedings of the Design Society: DESIGN Conference*, Vol. 1, pp. 41–50. <https://doi.org/10.1017/dsd.2020.128>.
- Kohn, A. (2014), *Entwicklung einer Wissensbasis für die Arbeit mit Produktmodellen [Development of a knowledge base for the work with product models]*, Dissertation, Technische Universität München.
- Leu, M.C., Wu, J.C. and Liu, X.F. (2009), “Axiomatic functional and object-oriented product design framework”, *CIRP Annals*, Vol. 58 No. 1, pp. 147–152. <https://doi.org/10.1016/j.cirp.2009.03.017>.
- Maier, A.M., Wynn, D., Howard, T.J. and Andreasen, M.M. (2014), “Perceiving Design as Modelling: A Cybernetic Systems Perspective”, in Chakrabarti, A. and Blessing, L. (Eds.), *An Anthology of Theories and Models of Design: Philosophy, Approaches and Empirical Explorations*, Springer London, London, pp. 133–149. https://doi.org/10.1007/978-1-4471-6338-1_7.
- Matthiesen, S., Grauberger, P., Bremer, F. and Nowoseltschenko, K. (2019a), “Product models in embodiment design: an investigation of challenges and opportunities”, *SN Applied Sciences*, Vol. 1 No. 9. <https://doi.org/10.1007/s42452-019-1115-y>.
- Matthiesen, S., Grauberger, P., Hölz, K., Nelius, T., Bremer, F., Wettstein, A., Gessinger, A., Pflegler, B., Nowoseltschenko, K. and Voß, K. (2018), *Modellbildung mit dem C&C²-Ansatz in der Gestaltung - Techniken zur Analyse und Synthese*. <https://doi.org/10.5445/IR/1000080744>.
- Matthiesen, S., Grauberger, P. and Schrempp, L. (2019b), “Extended Sequence Modelling in Design Engineering – Gaining and Documenting Knowledge about Embodiment Function Relations with the C&C² -Approach”, *Proceedings of the Design Society: International Conference on Engineering Design*, Vol. 1 No. 1, pp. 1483–1492. <https://doi.org/10.1017/dsi.2019.154>.
- Paehler, L., Grauberger, P. and Matthiesen, S. (2023), “Rethinking how we describe product models in engineering design research”, Preprint. <https://doi.org/10.5445/IR/1000164204>.
- Pahl, G., Beitz, W. and Wallace, K. (Eds.) (1996), *Engineering Design*, Springer London, London. <https://doi.org/10.1007/978-1-4471-3581-4>.
- Palani Rajan, P.K., van Wie, M., Campbell, M., Wood, K.L. and Otto, K.N. (2005), “An empirical foundation for product flexibility”, *Design Studies*, Vol. 26 No. 4, pp. 405–438. <https://doi.org/10.1016/j.destud.2004.09.007>.
- Pimmler, T.U. and Eppinger, S.D. (1994), “Integration Analysis of Product Decompositions”, in *6th International Conference on Design Theory and Methodology, 11.09.1994 - 14.09.1994, Minneapolis, Minnesota, USA*, American Society of Mechanical Engineers, pp. 343–351. <https://doi.org/10.1115/DETC1994-0034>.
- Štorga, M., Andreasen, M.M. and Marjanović, D. (2010), “The design ontology: foundation for the design knowledge exchange and management”, *Journal of Engineering Design*, Vol. 21 No. 4, pp. 427–454. <https://doi.org/10.1080/09544820802322557>.
- Sturm, C., Gwosch, T. and Matthiesen, S. (2020), “A modeling approach to identify the influences of relevant system parameters on drive train vibrations”, paper presented at INTER-NOISE 2020, 2020-8-23 - 2020-8-26, Seoul, Republic of Korea.
- Weidmann, D., Isemann, M., Kandlbinder, P., Hollauer, C., Kattner, N., Becerril, L. and Lindemann, U. (2017), “Product Models in Mechatronic Design: Literature Analysis on the Interdisciplinary Character of Product Models”, in *2017 Portland International Conference on Management of Engineering and Technology (PICMET), 09.07.2017 - 13.07.2017, Portland, OR*, IEEE, pp. 1–7. <https://doi.org/10.23919/PICMET.2017.8125397>.