

LATTICE PATHS AND A SERGEEV-PRAGACZ FORMULA FOR SKEW SUPERSYMMETRIC FUNCTIONS

A. M. HAMEL AND I. P. GOULDEN

ABSTRACT. We obtain a new version of the Sergeev-Pragacz formula for supersymmetric functions of standard shape—one applicable to arbitrary skew shape. The result involves an antisymmetrized sum of determinants that are themselves flagged supersymmetric functions. The proof is combinatorial, and follows by means of lattice path transformations.

1. Introduction. The Sergeev-Pragacz formula—a ratio of alternants formula for supersymmetric functions—was discovered independently by van der Jeugt *et al.* ([8]) and Sergeev, and has inspired much activity in recent years. It has spawned several algebraic proofs, beginning with Pragacz [13], and including Bergeron and Garsia [2], Lascoux (see Macdonald [10]), and Pragacz and Thorup [14]. Papers linking this formula with characters of polynomial representations of the Lie superalgebra $sl(m/n)$ [8], [1], the Littlewood-Richardson Rule [2], [7], and Schubert polynomials [10] have also appeared, building a solid base of knowledge and interest. In this paper we use combinatorial methods to generalize the Sergeev-Pragacz formula to skew supersymmetric functions (Theorem 3). This formula, which reduces for standard shape to give a direct and concise combinatorial proof of the Sergeev-Pragacz Formula, has a proof based on lattice path representations as introduced in Gessel and Viennot [4] and Bressoud and Wei [3].

Let λ be a *partition* of k with (at most) l parts, *i.e.* $\lambda = (\lambda_1, \dots, \lambda_l)$ where $\lambda_1 \geq \lambda_2 \geq \dots \geq \lambda_l$ are nonnegative integers and $\lambda_1 + \lambda_2 + \dots + \lambda_l = k$. A partition can be represented in the plane by an arrangement of squares that is left and top justified with λ_i squares in the i -th row. Such an arrangement is called a *Ferrers diagram*, and since it is left and top justified, we say it has *standard shape*. Given two partitions, λ and μ , we say $\mu \subseteq \lambda$ if $\mu_i \leq \lambda_i$ for all $i \geq 1$. Then we say a Ferrers diagram has *skew shape* λ/μ for $\mu \subseteq \lambda$ if it includes a square in row i , column j iff $\mu_i < j \leq \lambda_i$. Geometrically, this is the Ferrers diagram of λ with the Ferrers diagram of μ removed from its upper left hand corner. Note that the standard shape λ is just the skew shape λ/μ with $\mu = \emptyset$.

Associated with each skew shape is its *conjugate*. The conjugate of a skew shape λ/μ is defined to be the skew shape λ'/μ' whose Ferrers diagram is the transpose of the Ferrers diagram of λ/μ . More explicitly, the number of squares in the i -th row of λ'/μ' is the number of squares in the i -th column of λ/μ .

If we insert positive integers into the squares of a skew shape λ/μ such that the entries strictly increase down each column and weakly increase left to right along each row,

Received by the editors June 7, 1993.

AMS subject classification: Primary: 05E05; secondary: 05A15, 15A15.

© Canadian Mathematical Society, 1995.

we say we have a *tableau* of (skew) shape λ/μ . In a tableau we use $T(\alpha)$ to denote the positive integer in square α of the Ferrers diagram whose shape is T .

We assume a finite number of variables and adopt the conventions $x = (x_1, \dots, x_n)$ and $y = (y_1, \dots, y_m)$. Note also that the product $x_1^{\lambda_1} \cdots x_n^{\lambda_n}$ is denoted by x^λ , while $x_1^{n-1} \cdots x_n^0$ is denoted by x^δ . The Vandermonde determinant, $\det(x_i^{n-j})_{n \times n}$, will be denoted by $V(x)$.

Define the complete (homogeneous) and elementary symmetric functions, $h_k(x)$ and $e_k(y)$, ($k \geq 0$) respectively as

$$\sum_{k \geq 0} h_k(x)t^k = \prod_{j=1}^n (1 - x_j t)^{-1},$$

$$\sum_{k \geq 0} e_k(y)t^k = \prod_{j=1}^m (1 + y_j t),$$

and the skew Schur function $s_{\lambda/\mu}(x)$ as

$$s_{\lambda/\mu}(x) = \sum_T \prod_{\alpha \in \lambda/\mu} x_{T(\alpha)},$$

where the summation is over tableaux T of shape λ/μ and $\alpha \in \lambda/\mu$ means that α ranges over all squares in the Ferrers diagram of λ/μ .

Further characterizations of the skew Schur function include the Jacobi-Trudi identity:

(1)
$$s_{\lambda/\mu}(x) = \det(h_{\lambda_i - \mu_j - i + j}(x))_{l \times l},$$

and its dual form,

(2)
$$s_{\lambda/\mu}(y) = \det(e_{\lambda'_i - \mu'_j - i + j}(y))_{\lambda_1 \times \lambda_1},$$

(assume λ has l parts). All of these representations hold for countable sets of variables.

For the Schur function, $s_\lambda(x) = s_{\lambda/\emptyset}(x)$, there is also an expression as a ratio of alternants:

(3)
$$s_\lambda(x) = \frac{\det(x_i^{\lambda_j + n - j})_{n \times n}}{V(x)}.$$

This expression necessarily involves a finite number of variables, n , and λ has n parts.

A function in two independent sets of variables, $x = (x_1, \dots, x_n)$ and $y = (y_1, \dots, y_m)$ is said to be *supersymmetric* if it is symmetric in x and y separately and if it satisfies an additional cancellation property: given the substitution $x_1 = t, y_1 = -t$, the resulting polynomial is independent of t . These functions, then called bisymmetric, were first introduced by Metropolis *et al.* [12]. The name *supersymmetric* apparently first appeared in Scheunert [15].

Define the complete (homogeneous) supersymmetric function, $h_k(x \setminus y)$ ($k \geq 0$) as

$$\sum_{k \geq 0} h_k(x \setminus y)t^k = \prod_{i=1}^n (1 - x_i t)^{-1} \prod_{j=1}^m (1 + y_j t),$$

in terms of which the *skew supersymmetric Schur function* can be defined as

(4)
$$s_{\lambda/\mu}(x \setminus y) = \det(h_{\lambda_i - \mu_j - i + j}(x \setminus y))_{l \times l}$$

—a Jacobi-Trudi determinant (assume λ has l parts). A further characterization is the following:

$$s_{\lambda/\mu}(x \setminus y) = \sum_{\nu} s_{\nu/\mu}(x) s_{\lambda'/\nu'}(y).$$

Other descriptions, as tableau generating functions, can be found in Berele and Regev [1], Goulden and Greene [6], and Macdonald [11]. All these hold for countable sets of variables.

For the supersymmetric Schur function, $s_{\lambda}(x \setminus y) = s_{\lambda/\emptyset}(x \setminus y)$, there is an analogous form to the ratio of alternants involving two necessarily finite sets of variables (although λ has an arbitrary number of parts):

$$(5) \quad s_{\lambda}(x \setminus y) = \frac{1}{V(x)V(y)} \sum_{\sigma \in S_n} \sum_{\rho \in S_m} \text{sgn } \sigma \text{sgn } \rho \sigma \rho \left(x^{\delta} y^{\delta} \prod_{(i,j) \in \lambda} (x_i + y_j) \right),$$

where $(i, j) \in \lambda$ means the square in row i and column j of the Ferrers diagram of λ , and where we note the conventions that σ acts only on x (homomorphically from $\sigma(x_i) = x_{\sigma(i)}$), ρ acts only on y , $x_i = 0$ for $i > n$, and $y_j = 0$ for $j > m$. The main thrust of this paper is to generalize (5), called the Sergeev-Pragacz formula, to skew shape.

The second section introduces background information on lattice paths and some techniques for manipulating them. The third section extends the ratio of alternants form for the Schur function, (3), to skew shape and also independently proves an analogous dual result. The proofs are combinatorial and are based on Bressoud and Wei’s lattice path proof of (3) for standard shape [3]. The fourth section expands upon the results of Section 3 to produce a Sergeev-Pragacz formula for skew supersymmetric functions (assume λ has l parts):

$$(6) \quad s_{\lambda/\mu}(x \setminus y) = \frac{1}{V(x)V(y)} \sum_{\sigma \in S_n} \sum_{\rho \in S_m} \text{sgn } \sigma \text{sgn } \rho \sigma \rho \left(x^{\delta} y^{\delta} \det(h_{\lambda_i - \mu_j - i + j}(x_1, \dots, x_i \setminus y_1, \dots, y_{\lambda_i}))_{l \times l} \right),$$

and also details the specialization of (6) to (5). A final section explores the connections between the results of Section 3 and flagged skew Schur functions. This includes a proof of the equivalence of Theorems 1 and 2, the definition of flagged supersymmetric skew Schur functions, and generalizations of Theorems 1, 2, and 3.

2. Lattice paths. The foundation of the proofs in this paper rests on the manipulation of *lattice paths*. Fix points P_1, \dots, P_m and Q_1, \dots, Q_m in the (x, y) -plane. A lattice path from P_i to Q_j has two types of permissible steps: vertical steps, which increase the y -coordinate by one, and horizontal steps, which increase the x -coordinate by one. Note that if a horizontal step occurs at y -coordinate j , we say the step occurs at *height* j . If a horizontal step occurs at x -coordinate i and y -coordinate j , we say the step occurs at *diagonal* $i + j$.

An m -tuple of lattice paths from P_1, \dots, P_m to Q_1, \dots, Q_m has its i -th path from $P_{\tau(i)}$ to Q_i , $i = 1, \dots, m$, for some permutation $\tau \in S_m$, called the *starting permutation* of the m -tuple. We adopt the following restrictions on the starting and ending points: both the starting points P_1, \dots, P_m and the ending points Q_1, \dots, Q_m must be weakly decreasing in the y -coordinate and strictly increasing in the x -coordinate as we move from left to right. An m -tuple of lattice paths is said to be *intersecting* if two or more paths in the m -tuple pass through a common point in the plane; otherwise, the m -tuple is said to be *nonintersecting*. Note that our restrictions on the starting and ending points imply that all nonintersecting m -tuples of lattice paths from P_1, \dots, P_m to Q_1, \dots, Q_m have the identity as the starting permutation.

The *Gessel-Viennot* [4] *image* of an intersecting m -tuple of lattice paths is the intersecting m -tuple of lattice paths formed as follows:

Choose the maximum indexed path that intersects other paths, the last intersection point on this path, and the maximum indexed *other* path that passes through this intersection point. In the chosen paths, interchange the portions preceding the chosen intersection point.

The procedure above guarantees that an m -tuple and its Gessel-Viennot image have the same multiset of steps, but starting permutations of opposite sign. Thus this procedure defines a fixed-point free involution on the set of intersecting m -tuples of lattice paths.

Now for each horizontal step beginning at coordinates (i, j) , choose a weight depending only on i and j . For each vertical step, regardless of position, choose a weight of one.

Consider

$$(7) \quad \det(g(P_j, Q_i))_{m \times m} = \sum_{\tau \in S_m} \operatorname{sgn} \tau \prod_{i=1}^m g(P_{\tau(i)}, Q_i),$$

where $g(P_j, Q_i)$ is the sum over all paths from P_j to Q_i of the product of the weights on the individual steps. Now if the weight of an m -tuple of lattice paths with starting permutation τ is $\operatorname{sgn} \tau$ times the product of the weights of the individual steps in the m -tuple, then (7) is the generating function with respect to this weight for the set of m -tuples of paths from P_1, \dots, P_m to Q_1, \dots, Q_m . The above analysis demonstrates that the total contribution to this generating function from the set of intersecting m -tuples of lattice paths is zero, since each m -tuple cancels with its Gessel-Viennot image. Thus (7) simplifies to the generating function for *nonintersecting* m -tuples of lattice paths from P_1, \dots, P_m to Q_1, \dots, Q_m in which each of these nonintersecting m -tuples necessarily has the identity—which has positive sign—as the starting permutation. We call this result the *Gessel-Viennot Result*.

EXAMPLE 2.1. The well-known Jacobi-Trudi identity,

$$s_{\lambda/\mu}(x) = \det(h_{\lambda_i - \mu_j - i + j}(x))_{l \times l},$$

given as (1) above, is a special case of the Gessel-Viennot Result with starting and ending points $P_i = (\mu_i - i + 1, 1)$ and $Q_i = (\lambda_i - i + 1, m)$, $i = 1, \dots, l$, and a weight of x_j for each horizontal step beginning at coordinates (i, j) . Then the l -tuples of nonintersecting

paths within this framework are in one-to-one correspondence with tableaux of shape λ/μ (i.e. horizontal steps in path i occur at heights specified by the entries in row i of the tableau), and $g(P_j, Q_i) = h_{\lambda_i - \mu_j - i + j}(x)$.

EXAMPLE 2.2. The dual Jacobi-Trudi identity,

$$s_{\lambda'/\mu'}(y) = \det(e_{\lambda_i - \mu_j - i + j}(y))_{l \times l'}$$

given as (2) above, also lends itself to interpretation in this manner. The starting and ending points are $P_i = (\mu_i - i + 1, -\mu_i + i)$ and $Q_i = (\lambda_i - i + 1, m - \lambda_i + i)$, $i = 1, \dots, l$, and the weight is y_{i+j} for each horizontal step beginning at coordinates (i, j) . Then the l -tuples of nonintersecting paths within this framework are in one-to-one correspondence with tableaux of shape λ'/μ' (i.e. a horizontal step in path j occurs at height $\alpha_{i,j} + j - i$ where $\alpha_{i,j}$ is the element in row i , column j of the tableau), and $g(P_j, Q_i) = e_{\lambda_i - \mu_j - i + j}(y)$.

3. **Extensions of Bressoud and Wei.** Translating the directed graphs proof of Goulden [5] into a lattice path environment, Bressoud and Wei [3] give a combinatorial proof of the following (λ has n parts):

$$(8) \quad V(x) \det(h_{\lambda_i - i + j}(x))_{n \times n} = \det(x_j^{\lambda_i + n - i})_{n \times n},$$

a result that equates the Jacobi-Trudi determinant form to the ratio of alternants form of the Schur function for standard shape λ . Here we extend Bressoud and Wei’s proof to derive an analogous result for skew shape λ/μ . This result appears below as Theorem 1. Before proving Theorem 1, we note an important type of lattice path that figures in Bressoud and Wei’s proof, a *too high* lattice path. We say a lattice path is too high if it has a horizontal step above height i . An l -tuple of lattice paths is too high if one or more of the paths is too high.

THEOREM 1. *Let λ be a partition with l parts, and $\mu \subseteq \lambda$, then*

$$V(x) \det(h_{\lambda_i - \mu_j - i + j}(x))_{l \times l} = \sum_{\sigma \in S_n} \text{sgn } \sigma \sigma(x^\delta \det(h_{\lambda_i - \mu_j - i + j}(x_1, \dots, x_i))_{l \times l}).$$

PROOF. Fix points $P_i = (\mu_i - i + 1, 1)$ and $Q_i = (\lambda_i - i + 1, m)$, $i = 1, \dots, l$, as in Example 2.1. For each $\sigma \in S_n$ consider the l -tuples of lattice paths from P_1, \dots, P_l to Q_1, \dots, Q_l where we weight a horizontal step at height j by $x_{\sigma(j)}$. Define the weight of such an l -tuple as the product of the weights of the individual steps times

$$\text{sgn } \sigma \sigma(x^\delta) \text{sgn } \tau,$$

where τ is the starting permutation of the l -tuple. Figure 1 gives an example of an l -tuple with $\lambda = (8, 8, 5, 4)$, $\mu = (4, 3, 3, 0)$, $n = 6$, $l = 4$.

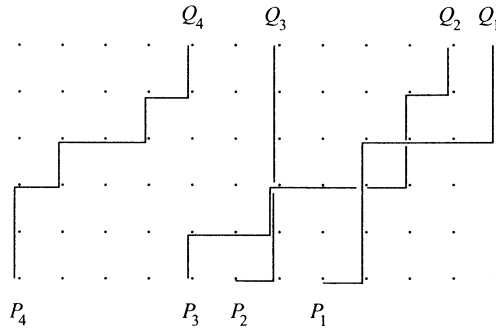

FIGURE 1: A 4-TUPLE OF LATTICE PATHS

Then if we sum the weight over all σ and all such l -tuples and use (7) as in Example 2.1, we obtain

$$(9) \quad \sum_{\sigma \in S_n} \text{sgn } \sigma \sigma \left(x^\delta \det(h_{\lambda_i - \mu_j - i + j}(x))_{l \times l} \right) = V(x) \det(h_{\lambda_i - \mu_j - i + j}(x))_{l \times l}.$$

Thus we have a lattice path interpretation for the left hand side of the result.

However, if we sum the weight over all σ but over only those l -tuples that *are not* too high, we get

$$(10) \quad \sum_{\sigma \in S_n} \text{sgn } \sigma \sigma \left(x^\delta \det(h_{\lambda_i - \mu_j - i + j}(x_1, \dots, x_i))_{l \times l} \right).$$

In this case we have used (7) with $g(P_j, Q_i) = h_{\lambda_i - \mu_j - i + j}(x_1, \dots, x_i)$, the generating function for paths from P_j to Q_i with no horizontal steps above height i . This gives a lattice path interpretation of the right hand side of the result.

We now prove the result by demonstrating that the sum of the weights over all σ , but over only those l -tuples that *are* too high, is zero. We do so by finding a sign-reversing involution that maps each pair consisting of a permutation and a too high l -tuple of lattice paths to another such pair so the weights of the pair and its image sum to zero.

The involution has the following description. Consider an arbitrary pair consisting of a permutation σ and a too high l -tuple of lattice paths. Let path j be the too high path of smallest subscript in the l -tuple, and let t be the greatest height of a horizontal step in path j .

Modify the l -tuple of lattice paths by leaving one step at height t in path j fixed but moving all other steps at height t in *all paths* down to height $t - 1$ and moving all steps at height $t - 1$ in *all paths* up to height t . The image under the involution is the pair consisting of the permutation $\sigma' = \sigma(t, t - 1)$ and the modified l -tuple of lattice paths. Figure 2 gives the modified 4-tuple of lattice paths corresponding to the 4-tuple

in Figure 1.

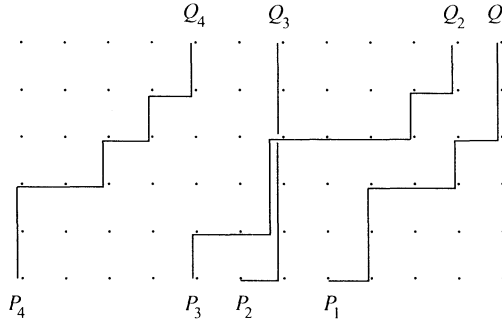

FIGURE 2: A MODIFIED 4-TUPLE OF LATTICE PATHS

It is straightforward to verify that this defines an involution. Moreover $\text{sgn } \sigma' = -\text{sgn } \sigma$, the starting permutation is unchanged, and the powers of x in the weight are the same for the l -tuple and the modified l -tuple. Thus the weights of a pair and its image cancel, as required. ■

Theorem 1 does indeed specialize to (8) for standard shape. To see this we utilize the same set-up as in Theorem 1 and then invoke the Gessel-Viennot procedure, as was done by Bressoud and Wei [3]:

COROLLARY 1. *Let λ be a partition with l parts. Then*

$$\det(h_{\lambda_i - i + j}(x_1, \dots, x_i))_{l \times l} = x^\lambda.$$

PROOF. Consider the starting and ending points of Theorem 1 in the case $\mu = \emptyset$, and σ equal to the identity. Then, from the proof of Theorem 1 and the Gessel-Viennot result, the left hand side of the corollary is the generating function for the set of nonintersecting l -tuples of not too high paths from P_1, \dots, P_l to Q_1, \dots, Q_l . But the only such nonintersecting l -tuple has starting permutation, τ , equal to the identity, and path i consisting of vertical steps from P_i to the line $y = i$, followed by λ_i horizontal steps to $(\lambda_i - i + 1, i)$, and finally vertical steps from there to $Q_i, i = 1, \dots, l$. The product of weights of these steps is $x_i^{\lambda_i}$, and taking the product over i gives the right hand side. ■

Note that if $l > n$, then, because of our convention $x_k = 0$ for $k > n$, the expression on the right hand side of Corollary 1—which we substitute into the right hand side of Theorem 1 to get (8)—reduces to 0 as required.

As we saw with Examples 2.1 and 2.2, there is a certain duality where the complete and elementary symmetric functions are concerned. It is therefore not surprising that we can obtain a dual result for Theorem 1. The combinatorial proof, however, involves a new and different mapping.

THEOREM 2. Let λ be a partition with l parts and let $\mu \subseteq \lambda$, then

$$V(y) \det(e_{\lambda_i - \mu_j - i + j}(y))_{l \times l} = \sum_{\rho \in S_m} \text{sgn } \rho \rho \left(y^\delta \det(e_{\lambda_i - \mu_j - i + j}(y_1, \dots, y_{\lambda_i}))_{l \times l} \right).$$

PROOF. Fix points $P_i = (\mu_i - i + 1, -\mu_i + i)$ and $Q_i = (\lambda_i - i + 1, m - \lambda_i + i), i = 1, \dots, l$ as in Example 2.2. For each $\rho \in S_m$ consider the l -tuples of lattice paths from P_1, \dots, P_l to Q_1, \dots, Q_l where we weight a horizontal step at coordinates (i, j) by $y_{\rho(i+j)}$. Define the weight of such an l -tuple as the product of the weights of the individual steps times

$$\text{sgn } \rho \rho(y^\delta) \text{sgn } \tau,$$

where τ is the starting permutation of the l -tuple. Figure 3 gives an example of such an l -tuple with $\lambda = (5, 3, 3, 2), \mu = (2, 2, 0, 0), m = 6, l = 4$.

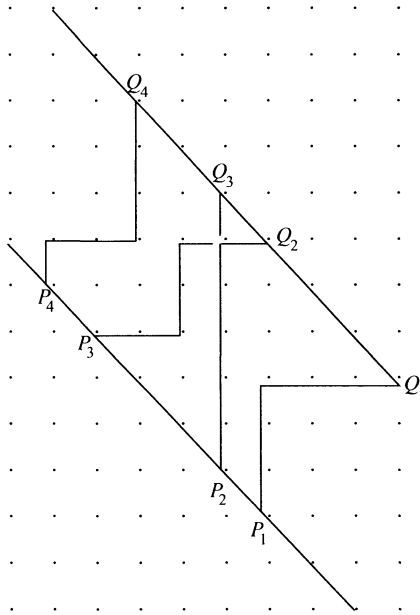

FIGURE 3: A 4-TUPLE OF LATTICE PATHS WITH DIAGONAL WEIGHTS

Then if we sum the weight over all ρ and all such l -tuples and use (7) as in Example 2.2, we obtain

$$(11) \quad \sum_{\rho \in S_m} \text{sgn } \rho \rho \left(y^\delta \det(e_{\lambda_i - \mu_j - i + j}(y))_{l \times l} \right) = V(y) \det(e_{\lambda_i - \mu_j - i + j}(y))_{l \times l}.$$

Thus we have a lattice path interpretation for the left hand side of the result.

However, if we sum the weight over all ρ but over only those l -tuples that *are not* too high, we get

$$(12) \quad \sum_{\rho \in S_m} \text{sgn } \rho \rho \left(y^\delta \det(e_{\lambda_i - \mu_j - i + j}(y_1, \dots, y_{\lambda_i}))_{l \times l} \right).$$

In this case we have used (7) with $g(P_j, Q_i) = e_{\lambda_i - \mu_j - i + j}(y_1, \dots, y_{\lambda_i})$, the generating function for paths from P_j to Q_i with no horizontal steps above height i . This gives a lattice path interpretation of the right hand side of the result.

We now prove the result by demonstrating that the sum of the weights over all ρ , but over only those l -tuples that *are* too high, is zero. We do so by first partitioning the set of pairs consisting of permutations and too high l -tuples of lattice paths into two sets, \mathcal{A} and \mathcal{B} , and then finding two sign-reversing involutions, one on \mathcal{A} and one on \mathcal{B} , that map each pair consisting of a permutation and a too high l -tuple of lattice paths to another such pair so the weights of the pair and its image sum to zero.

Starting from the left (that is, the highest indexed path), examine the paths from left to right until we encounter the first one that is too high. Suppose it is path j . Let \mathcal{A} be the set of permutation, l -tuple pairs such that this first too high path intersects other paths. Let \mathcal{B} be the set consisting of permutation, l -tuples pairs such that this first too high path does not intersect other paths.

INVOLUTION ON \mathcal{A} . Consider an arbitrary element in \mathcal{A} consisting of a permutation ρ and a too high l -tuple of lattice paths. Recall that path j is the first too high path and that it necessarily intersects other paths. Interpreting the l -tuple as a graph with the integer lattice points as vertices and the steps as edges, locate the component of this graph containing path j . Modify the l -tuple of lattice paths by finding the Gessel-Viennot image of the paths in this component while leaving all other paths unchanged. The image under this involution is the pair consisting of ρ and the modified l -tuple of lattice paths. Figure 4 gives the modified 4-tuple of lattice paths corresponding to the 4-tuple in Figure 3.

To ensure that this procedure is an involution, we must verify that the Gessel-Viennot image of the component also has a too high path. This is clearly true if path j is still too high. Otherwise the Gessel-Viennot intersection point (where path j switches with path k , say) must have occurred after the last horizontal step in path j , and thus must be above height j . Thus path k ends to the right of path j , and, in the Gessel-Viennot image, k has a step above height $j > k$, implying path k is too high, and giving us the contradiction we need.

The only remaining problem would be if path a for some $k < a < j$ is too high, yet belongs to a different component. But this is impossible because the ending point of path a is separated from all starting points by the terminal portions of paths j and k , and so path a for $k < a < j$ must intersect path j or k or both.

Finally, the weights of the pair and its image cancel as required since their starting permutations are of opposite sign (they differ by the transposition (k, j)), but ρ and all

their horizontal steps remain unchanged.

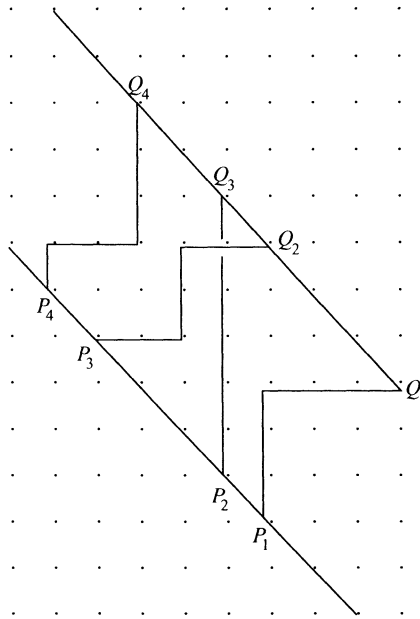

FIGURE 4: A MODIFIED 4-TUPLE OF LATTICE PATHS IN \mathcal{A}

INVOLUTION ON \mathcal{B} . For the involution \mathcal{B} it is useful to define a *jump* in a path: a jump at diagonal d is a vertical step at diagonal $d - 1$ followed immediately by a horizontal step at diagonal d . Consider an arbitrary element in \mathcal{B} consisting of a permutation ρ and a too high l -tuple of lattice paths. Recall that j is the first too high path and that path j intersects no other paths. First note that this forces j to be a fixed point under the starting permutation τ . Next note that path j must have a jump, for it starts at height $j - \mu_j$ and, being too high, has a horizontal step at height greater than j . Suppose the last jump in path j occurs at diagonal t and height a (necessarily $a > j$).

Modify the l -tuple of paths in the following way. Leave path j unchanged. In all other paths interchange the step (vertical or horizontal) at diagonal $t - 1$ and the step (vertical or horizontal) at diagonal t . The image under the involution is the pair consisting of the permutation $\rho' = \rho(t, t - 1)$ and the modified l -tuple of lattice paths. Figure 5 gives such an l -tuple and its image under this modification in the case $\lambda = (5, 3, 3, 2), \mu = (2, 2, 0, 0), m = 6, l = 4$.

To prove that this defines an involution, we examine in more detail the original l -tuple of paths. For $i > j$, path i has no horizontal steps above height i , since from the left j is the first too high path. Thus path i passes through the point $(\lambda_i - i + 1, i)$ on diagonal $\lambda_i + 1$ and has only vertical steps thereafter. Recall that path j intersects no other path and, in particular, path j does not intersect path $j + 1$. Thus $(\lambda_{j+1} - j, j + 1)$, the point past

which path $j + 1$ is vertical, must occur strictly to the left of $(t - a, a)$, the point at which path j has a jump (since $a \geq j + 1$), so

$$\lambda_{j+1} - j \leq t - a - 1$$

which implies

$$\begin{aligned} \lambda_{j+1} &\leq t - a + j - 1 \\ &\leq t - 2. \end{aligned}$$

But λ is a partition, so

$$\lambda_l \leq \lambda_{l-1} \leq \dots \leq \lambda_{j+1} \leq t - 2,$$

and we conclude that path i is vertical above diagonal $t - 1$ for all $i > j$.

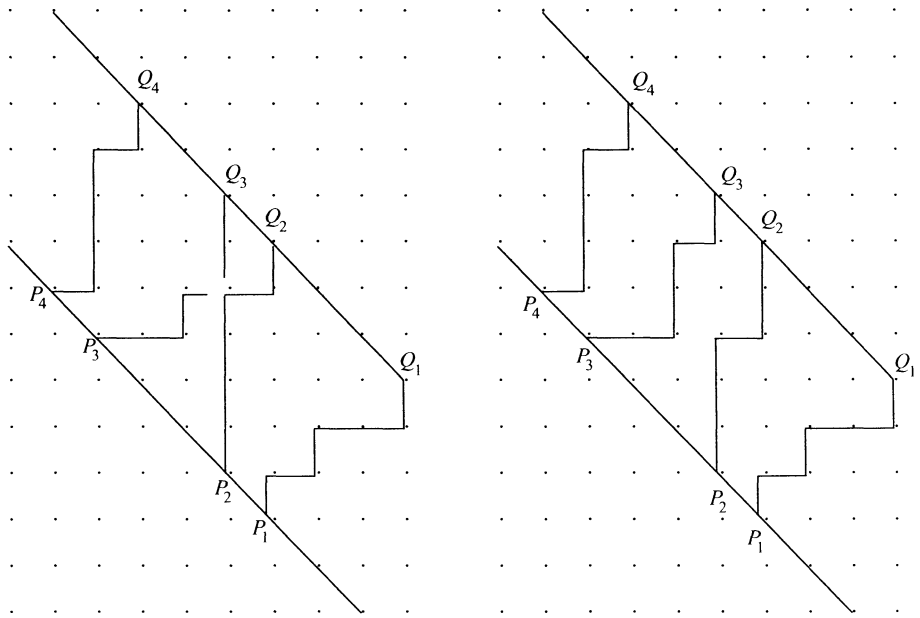

FIGURE 5: A 4-TUPLE IN \mathcal{B} AND ITS IMAGE

Thus path i is unchanged by the modification above for all $i \geq j$. Hence in the *modified* l -tuple, path j is still the highest indexed too high path, and path j still does not intersect any path with a higher index. The only difficulty that might arise is if a path of lower index that did not originally intersect path j is modified to intersect path j .

However, this cannot happen, for if the modified lower indexed path intersects path j at diagonal t , the original lower indexed path must have intersected path j at diagonal

$t - 1$, and if the modified lower indexed path intersects path j at diagonal $t - 1$, the lower indexed path must have intersected path j at diagonal t .

Note that $\text{sgn } \rho' = -\text{sgn } \rho$, the starting permutation is unchanged, and the powers of y in the weight are the same for the l -tuple and the modified l -tuple. Thus the weight of a pair and its image cancel, as required. ■

Note that Theorem 2 also specializes for standard shape to the dual of result (8) that appeared above, namely

$$(13) \quad V(y) \det(e_{\lambda_i - i + j}(y))_{l \times l} = \det(y_j^{\lambda_i + m - i})_{\lambda_1 \times \lambda_1},$$

where λ has l parts and $\lambda_1 \leq m$.

COROLLARY 2. *Let λ be a partition with l parts. Then*

$$\det(e_{\lambda_i - i + j}(y_1, \dots, y_{\lambda_i}))_{l \times l} = y^{\lambda'}.$$

PROOF. Consider the starting and ending points of Theorem 2 in the case $\mu = \emptyset$, and ρ equal to the identity. Then, from the proof of Theorem 2 and the Gessel-Viennot Result, the left hand side of the corollary is the generating function for the set of nonintersecting l -tuples of not too high paths from P_1, \dots, P_l to Q_1, \dots, Q_l . But the only such nonintersecting l -tuple has starting permutation, τ , equal to the identity, and path i consisting of vertical steps from P_i to the line $y = i$, followed by λ_i horizontal steps to $(\lambda_i - i + 1, i)$, and finally vertical steps from there to $Q_i, i = 1, \dots, l$. The product of the weights of these steps is $y_1 \cdots y_{\lambda_i}$, and taking the product over i gives the right hand side. ■

If λ' has more than m parts, then, because of our convention $y_k = 0$ if $k > m$, the expression on the right hand side of Corollary 2—which we substitute into the right hand side of Theorem 2 to get (13)—reduces to 0 as required.

4. A Sergeev-Pragacz formula for Skew supersymmetric functions. In combining concepts and techniques from the proofs of Theorems 1 and 2, we can forge the proof of Theorem 3 below. This proof is purely combinatorial and pleasingly concise, and its appeal is immediately apparent: Theorem 3 simplifies easily to the well-known Sergeev-Pragacz formula in the same way that Theorems 1 and 2 reduce to the ratio of alternants results for standard shape. Recall that σ and ρ act on x and y separately, and also recall that $x_k = 0$ if $k > n$ while $y_k = 0$ if $k > m$.

THEOREM 3. *Let λ be a partition with l parts and $\mu \subseteq \lambda$, then*

$$V(x)V(y) \det(h_{\lambda_i - \mu_j - i + j}(x \setminus y))_{l \times l} \\ = \sum_{\sigma \in S_n} \sum_{\rho \in S_m} \text{sgn } \sigma \text{sgn } \rho \sigma \rho \left(x^\delta y^\delta \det(h_{\lambda_i - \mu_j - i + j}(x_1, \dots, x_i \setminus y_1, \dots, y_{\lambda_i}))_{l \times l} \right).$$

PROOF. Fix points $P_i = (\mu_i - i + 1, -n - \lambda_1 + 2)$ and $Q_i = (\lambda_i - i + 1, m - \lambda_i + i)$, $i = 1, \dots, l$. For each $\sigma \in S_n$ and $\rho \in S_m$ consider the l -tuples of lattice paths from P_1, \dots, P_l to Q_1, \dots, Q_l with only vertical steps in the region bounded by the lines $y = -\lambda_1 + 1$ and $y = -x + 1$ (called the triangular region). For these l -tuples of lattice paths we weight a horizontal step at coordinates (i, j) by $x_{\sigma(n+\lambda_1-1+j)}$ if (i, j) is in the region bounded by the line $y = -n - \lambda_1 + 2$ and the line $y = -\lambda_1 + 1$ (called the horizontal region), and by $y_{\rho(i+j)}$ if (i, j) is in the region above the line $y = -x + 1$ (called the diagonal region). Define the weight of such an l -tuple as the product of the weights of the individual steps times

$$\text{sgn } \sigma \sigma(x^\delta) \text{sgn } \rho \rho(y^\delta) \text{sgn } \tau,$$

where τ is the starting permutation of the l -tuple. Figure 6 gives such an l -tuple in the case $\lambda = (8, 5, 4, 2, 1)$, $\mu = (2, 1, 1, 0, 0)$, $n = 4$, $m = 5$, $l = 5$.

Then if we sum the weight over all σ and ρ and all such l -tuples and use (7) we obtain

$$\sum_{\sigma \in S_n} \sum_{\rho \in S_m} \text{sgn } \sigma \text{sgn } \rho \sigma \rho \left(x^\delta y^\delta \det \left(h_{\lambda_i - \mu_j - i + j}(x \setminus y) \right)_{l \times l} \right) = V(x)V(y) \det \left(h_{\lambda_i - \mu_j - i + j}(x \setminus y) \right)_{l \times l},$$

since paths from P_j to Q_i consist of a portion through the horizontal region and a portion through the diagonal region. These portions have generating functions $h_r(x)$ and $e_s(y)$ respectively, with $r + s = \lambda_i - \mu_j - i + j$, so $g(P_j, Q_i) = \sum_{r+s=\lambda_i-\mu_j-i+j} h_r(x)e_s(y)$. Thus we have a lattice path interpretation for the left hand side of the result.

In order to consider the right hand side, we first reconsider our notions of too high from Theorems 1 and 2. If a horizontal step in path i of an l -tuple occurs above the line $y = i$ in the diagonal region, we say the path is *diagonally too high*. If a horizontal step in path i occurs above the line $y = -n - \lambda_1 + 1 + i$ in the horizontal region, we say the path is *horizontally too high*. An l -tuple of lattice paths is horizontally (resp. diagonally) too high if it contains a horizontally (resp. diagonally) too high path. Note that in an l -tuple that is neither diagonally nor horizontally too high, any path i will have only vertical steps above the line $y = i$ and also only vertical steps between the lines $y = -x + 1$ and $y = -n - \lambda_1 + 1 + i$.

Now if we sum the weight over all σ and ρ but over only those l -tuples that are *neither* diagonally nor horizontally too high, we get

$$\sum_{\sigma \in S_n} \sum_{\rho \in S_m} \text{sgn } \sigma \text{sgn } \rho \sigma \rho \left(x^\delta y^\delta \det \left(h_{\lambda_i - \mu_j - i + j}(x_1, \dots, x_i \setminus y_1, \dots, y_{\lambda_i}) \right)_{l \times l} \right).$$

In this case we have used (7) with $g(P_j, Q_i) = h_{\lambda_i - \mu_j - i + j}(x_1, \dots, x_i \setminus y_1, \dots, y_{\lambda_i})$, the generating function for paths from P_j to Q_i with no horizontal steps between the lines $y = -n - \lambda_1 + 1 + i$ and $y = -x + 1$ and no horizontal steps above the line $y = i$. This

gives a lattice path interpretation of the right hand side of the result.

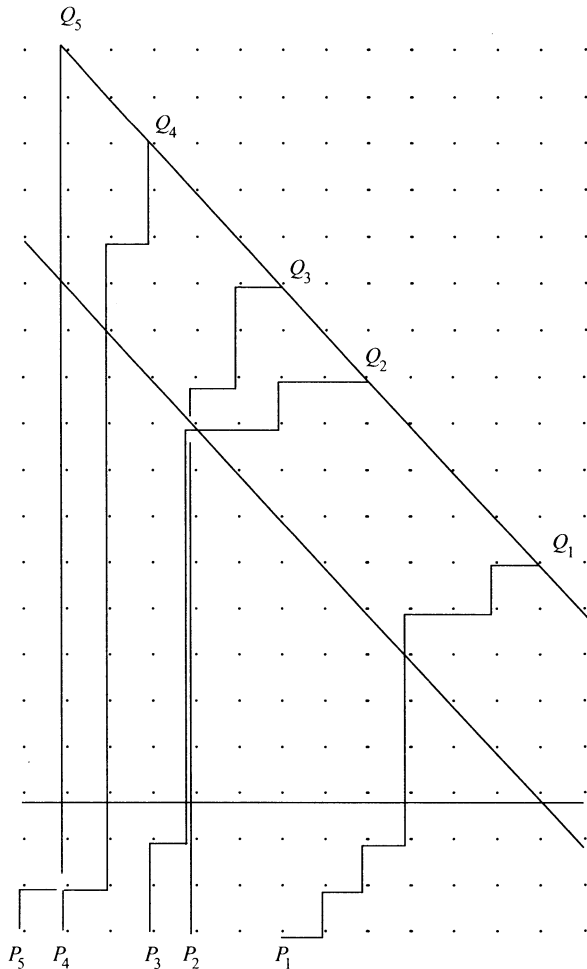

FIGURE 6: A 5-TUPLE OF LATTICE PATHS WITH HORIZONTAL AND DIAGONAL WEIGHTS

We now prove the result by demonstrating that the sum of the weights over all σ and ρ , but over only those l -tuples that are either diagonally or horizontally too high, is zero. We do so by finding a sign-reversing involution that maps each trio consisting of σ , ρ , and a too high (diagonally or horizontally) l -tuple of lattice paths to another such trio so the weights of the trio and its image sum to zero.

The sign-reversing involution proceeds with two stages. First, if the l -tuple is diagonally too high, apply the mapping of Theorem 2 to the portions of the paths in the diagonal region.

Second, if the l -tuple is *not* diagonally too high but *is* horizontally too high, apply the mapping of Theorem 1 to the portions of the paths in the horizontal region.

It is straightforward to verify that this defines an involution. In the first instance, the conclusion of Theorem 2 holds. In the second instance, the conclusion of Theorem 1 holds. Thus the weights of a trio and its image cancel as required. ■

As alluded to in Section 1, Theorem 3 specializes for standard shape to the familiar Sergeev-Pragacz formula by applying Corollary 3 below to the right hand side of Theorem 3. Recall the conventions $x_k = 0$ if $k > n$ and $y_k = 0$ if $k > m$.

COROLLARY 3. *Let λ be a partition with l parts. Then*

$$\det(h_{\lambda_i - i + j}(x_1, \dots, x_i \setminus y_1, \dots, y_{\lambda_i}))_{l \times l} = \prod_{(i,j) \in \lambda} (x_i + y_j).$$

PROOF. Consider the starting and ending points of Theorem 3 in the case $\mu = \emptyset$ and σ, ρ equal the identity. Then, from the proof of Theorem 3, the left hand side of the corollary is the generating function for the set of l -tuples of neither diagonally nor horizontally too high paths from P_1, \dots, P_l to Q_1, \dots, Q_l .

These neither diagonally nor horizontally too high l -tuples of paths must have the following form. The i -th path in the l -tuple must have only vertical steps beyond T_i , where

$$T_i = \begin{cases} (\lambda_i - i + 1, i), & i = 1, \dots, n, \lambda_i < m \\ Q_i, & \text{otherwise} \end{cases}$$

and also vertical steps from R_i to the line $y = -x + 1$, where

$$R_i = \begin{cases} (1 - i + \gamma_i, 1 - \lambda_1 - n + i), & i = 1, \dots, n \\ (1 - \tau(i), 1 - \lambda_1), & i > n \end{cases}$$

and $\gamma_i \geq 0, i = 1, \dots, n$.

Given this set of neither diagonally nor horizontally too high l -tuples, we select the subset of those for which the portions between $P_{\tau(i)}$ and R_i do not intersect. Call this set of l -tuples C . For each $\gamma_1, \dots, \gamma_n$ there is only one choice for these portions: τ must equal the identity, and, for $i = 1, \dots, n$, path i must consist of vertical steps from P_i to the line $y = -n - \lambda_1 + 1 + i$ and horizontal steps from there to R_i , while, for $i = n + 1, \dots, l$, path i must be vertical from P_i to R_i .

For $i = 1, \dots, n$, the weight contribution from the steps from P_i to R_i is $x_i^{\gamma_i}$, while the weight contribution from the steps from R_i to T_i is $e_{\lambda_i - \gamma_i}(y_1, \dots, y_{\lambda_i})$. Summing over all $\gamma_i \geq 0$ gives a total contribution from the i -th path in $C, i = 1, \dots, n$ of

$$(14) \quad \sum_{\gamma_i \geq 0} x_i^{\gamma_i} e_{\lambda_i - \gamma_i}(y_1, \dots, y_{\lambda_i}) = \prod_{j=1}^{\lambda_i} (x_i + y_j)$$

(recall the convention $y_k = 0$ for $k > m$). For $i = n + 1, \dots, l$, the weight contribution from the steps from P_i to R_i is 1, while the weight contribution from the steps from R_i to T_i is $e_{\lambda_i}(y_1, \dots, y_{\lambda_i}) = y_1 \cdots y_{\lambda_i}$. So we have a total contribution from the i -th path in $C, i = n + 1, \dots, l$ of

$$(15) \quad y_1 \cdots y_{\lambda_i}.$$

However, with the convention $x_k = 0$ if $k > n$, expressions (14) and (15) can be combined to give

$$\prod_{j=1}^{\lambda_i} (x_i + y_j),$$

for all $i = 1, \dots, l$.

Taking the product over all i we see that the weight sum of the l -tuples in C is

$$\prod_{(i,j) \in \lambda} (x_i + y_j),$$

the right hand side of Corollary 3.

If we can find a weight-cancelling involution that demonstrates that the sum of weights over l -tuples *not* in C is zero, then we will have achieved our purpose. Invoke the Gessel-Viennot procedure on the complement of C but consider only intersection points that occur in the segments from $P_{\tau(i)}$ to R_i . This defines a weight cancelling involution on the complement of C , so the result follows. ■

5. Connections to flagged Schur functions. The determinants present in the right hand sides of Theorems 1 and 2 are actually special cases of what are known as *row-flagged* and *column-flagged* skew Schur functions. The general definitions of these follow now.

We define $\mathcal{T}(\lambda/\mu, a, b)$ to be the set of all skew tableaux of shape λ/μ with *row flags* $a = a_1, \dots, a_n$ and $b = b_1, \dots, b_n$ (i.e. the entries in row i are bounded below by a_i and above by b_i). The row-flagged skew Schur function, $s_{\lambda/\mu}(a, b; x)$, is defined as

$$s_{\lambda/\mu}(a, b; x) = \sum_T \prod_{\alpha \in \lambda/\mu} x_{\mathcal{T}(\alpha)},$$

where the summation is over row-flagged skew tableaux $\mathcal{T}(\lambda/\mu, a, b)$ and $\alpha \in \lambda/\mu$ means that α ranges over all squares in the Ferrers diagram of λ/μ .

Moreover, if we make the assumption that $a_i \leq a_{i+1}$, and $b_i \leq b_{i+1}$ for $i = 1, \dots, n$, there is a Jacobi-Trudi result for these functions ([4], [16]):

$$(16) \quad s_{\lambda/\mu}(a, b; x) = \det(h_{\lambda_i - \mu_j - i + j}(x_{a_j}, x_{a_{j+1}}, \dots, x_{b_i}))_{l \times l}.$$

This result is true also under slightly weaker assumptions (see [16]); however, these conditions suffice for our purposes.

Note now the significance of (16). It means that the determinant on the right hand side of Theorem 1 is actually a row-flagged skew Schur function with $a = (1, 1, \dots, 1)$ and $b = (1, 2, \dots, l)$.

Now we define $\mathcal{T}^*(\lambda/\mu, a, b)$ to be the set of skew tableaux whose shape is the *conjugate* of λ/μ and whose *column flags* are $a = a_1, \dots, a_m$ and $b = b_1, \dots, b_m$ (i.e. the entries in column j are bounded below by a_j and above by b_j , $j = 1, \dots, m$). The column-flagged skew Schur function, $s_{\lambda/\mu}^*(a, b; y)$, is defined as

$$s_{\lambda/\mu}^*(a, b; y) = \sum_T \prod_{\alpha \in \lambda/\mu} y_{\mathcal{T}(\alpha)},$$

where the summation is over column-flagged skew tableaux $T^*(\lambda/\mu, a, b)$ and $\alpha \in \lambda/\mu$ means that α ranges over all squares in the Ferrers diagram of λ/μ .

Moreover, if we make the assumption that $a_j - \mu_j \leq a_{j+1} - \mu_{j+1} + 1$, and $b_j - \lambda_j \leq b_{j+1} - \lambda_{j+1} + 1, j = 1, \dots, m$, then there is a dual Jacobi-Trudi result for these functions ([4], [16]):

$$(17) \quad s_{\lambda/\mu}^*(a, b; y) = \det(e_{\lambda_i - \mu_j - i + j}(y_{a_j}, \dots, y_{b_i}))_{l \times l}.$$

This result is true also under slightly weaker assumptions (see [16]); however, these conditions suffice for our purposes.

Note now the significance of (17). It means that the determinant on the right hand side of Theorem 2 is actually a column-flagged skew Schur function with $a = (1, 1, \dots, 1)$ and $b = (\lambda_1, \lambda_2, \dots, \lambda_l)$.

It is important to note that row-flagged and column-flagged skew Schur functions are not generally equal. A judicious choice of flag conditions, however, can create equality. One instance of this appears in Macdonald [11]; another appears below.

THEOREM 4. *Let λ be a partition with l parts. Then*

$$\det(h_{\lambda_i - \mu_j - i + j}(x_1, \dots, x_i))_{l \times l} = \det(e_{\lambda'_i - \mu'_j - i + j}(x_1, \dots, x_{\lambda'_i}))_{\lambda_1 \times \lambda_1}.$$

PROOF. Exploiting the identifications provided by (16) and (17), we prove this theorem using the tableau definitions of row and column flagged skew Schur functions. First suppose we have a tableau satisfying the column bounds of 1 and λ_j . Then certainly all entries in row i are ≥ 1 . Now consider the entry in (i, j) . The largest element in column j is λ'_j and it can occur only in row λ'_j . Then because of column strictness we can count backwards to see that the largest element in (i, j) must be $\leq i$. So the tableau satisfies the row bounds as well.

Now suppose we have a tableau satisfying the row bounds of 1 and i . Then certainly all entries in column j are ≥ 1 . Now consider the entry in (i, j) . The largest possible element in row i is i . But i is always $\leq \lambda'_j$ since the largest row intersecting column j is at most λ'_j . So the tableau satisfies the column bounds as well.

Hence the same set of tableaux generates both determinants. ■

Because of Theorem 4, we see that Theorems 1 and 2 are actually the same theorem. Note however that we derived Theorems 1 and 2 separately, since we needed the techniques in the proofs of both Theorems 1 and 2 to prove Theorem 3.

Building on the models of the row- and column-flagged skew Schur functions we can proceed to define a *row-flagged supersymmetric Schur function*. The row-flagged supersymmetric skew Schur function, $s_{\lambda/\mu}(a, b, c, d; x, y)$, is defined as

$$s_{\lambda/\mu}(a, b, c, d; x, y) = \sum_{\nu} s_{\nu/\mu}(a, b; x) s_{\lambda/\nu}^*(c, d; y).$$

Moreover, if we make the assumptions $a_i \leq a_{i+1}, b_i \leq b_{i+1}, c_j - \mu_j \leq c_{j+1} - \mu_{j+1} + 1, d_j - \lambda_j \leq d_{j+1} - \lambda_{j+1} + 1, i = 1, \dots, n, j = 1, \dots, m$, then it follows easily by a Gessel-Viennot argument on the lattice path set-up of Theorem 3 that

$$s_{\lambda/\mu}(a, b, c, d; x, y) = \det(h_{\lambda_i - \mu_j - i+j}(x_{a_i}, \dots, x_{b_i} \setminus y_{c_j}, \dots, y_{d_i}))_{l \times l}$$

Note that, as in the two previous cases, this expression provides an identification of the determinant on the right hand side of Theorem 3 as a row-flagged skew supersymmetric Schur function.

Now that the right hand sides of Theorems 1 through 3 have been identified as flagged functions, we can ask the question: “For which flag conditions can the right hand side be extended so that Theorems 1, 2, and 3 are true?” A partial answer is given below in Theorems 5 through 7. The proofs are analogous to those for Theorems 1 through 3 with the only major change being slight alterations to the notion of *too high*. To extend Theorem 1 to Theorem 5, replace “height above i ” by “height above η_i .” To extend Theorem 2 to Theorem 6, replace “height above i ” by “height above $i + \nu_i - \lambda_i$.” The proof of Theorem 7 is obtained from those of Theorems 5 and 6 in the same way that the proof of Theorem 3 was obtained from those of Theorems 1 and 2.

THEOREM 5. *Let λ be a partition with l parts, and $\mu \subseteq \lambda$, then*

$$V(x) \det(h_{\lambda_i - \mu_j - i+j}(x))_{l \times l} = \sum_{\sigma \in S_n} \text{sgn } \sigma \sigma \left(x^\delta \det(h_{\lambda_i - \mu_j - i+j}(x_1, \dots, x_{\eta_i}))_{l \times l} \right),$$

where $0 < \eta_1 < \eta_2 < \dots < \eta_k < n, \eta_{k+1} = \dots = \eta_l = n$, and where $k \geq 0$.

THEOREM 6. *Let λ be a partition with l parts, and $\mu \subseteq \lambda$, then*

$$V(y) \det(e_{\lambda_i - \mu_j - i+j}(y))_{l \times l} = \sum_{\rho \in S_m} \text{sgn } \rho \rho \left(y^\delta \det(e_{\lambda_i - \mu_j - i+j}(y_1, \dots, y_{\nu_i}))_{l \times l} \right),$$

under the following conditions: 1) $\nu_l - \lambda_l \leq \nu_{l-1} - \lambda_{l-1} \leq \dots \leq \nu_t - \lambda_t, \nu_l \leq \nu_{l-1} \leq \dots \leq \nu_t < m$, and $\nu_{t-1} = \dots = \nu_1 = m$, and 2) $t \leq l + 1$.

THEOREM 7. *Let λ be a partition with l parts, and $\mu \subseteq \lambda$, then*

$$V(x)V(y) \det(h_{\lambda_i - \mu_j - i+j}(x \setminus y))_{l \times l} = \sum_{\sigma \in S_n} \sum_{\rho \in S_m} \text{sgn } \sigma \text{sgn } \rho \sigma \rho \left(x^\delta y^\delta \det(h_{\lambda_i - \mu_j - i+j}(x_1, \dots, x_{\eta_i} \setminus y_1, \dots, y_{\nu_i}))_{l \times l} \right),$$

under the following conditions: 1) $0 < \eta_1 < \eta_2 < \dots < \eta_k < n, \eta_{k+1} = \dots = \eta_l = n$; 2) $k \geq 0$; 3) $\nu_l - \lambda_l \leq \nu_{l-1} - \lambda_{l-1} \leq \dots \leq \nu_t - \lambda_t, \nu_l \leq \nu_{l-1} \leq \dots \leq \nu_t < m$, and $\nu_{t-1} = \dots = \nu_1 = m$; and 4) $t \leq l + 1$.

Note that the right hand sides of Theorems 5 through 7 involve restricted classes of flagging conditions. Indeed the analogous results are not true if an arbitrary Jacobi-Trudi determinantal form of flagged Schur function appears on the right hand side. For example, for Theorem 5, let $n = 2, \lambda = (2, 1), \mu = (1, 0)$, and $\eta_1 = \eta_2 = 1$. Then $\sum_{\sigma \in S_n} \text{sgn } \sigma \sigma \left(x^\delta \det(h_{\lambda_i - \mu_j - i+j}(x_1))_{2 \times 2} \right) = V(x)s_2(x_1, x_2)$, not $V(x)s_{(2,1)/(1,0)}(x_1, x_2)$, even though $\det(h_{\lambda_i - \mu_j - i+j}(x_1))_{2 \times 2} = x_1^2$ is a row-flagged Schur function.

ACKNOWLEDGEMENTS. This work was supported by grant A8907 from the Natural Sciences and Engineering Research Council of Canada (I.P.G.), a War Memorial Scholarship from the Imperial Order of the Daughters of the Empire (A.M.H.), and the J. H. Stewart Reid Memorial Fellowship from the Canadian Association of University Teachers (A.M.H.).

REFERENCES

1. A. Berele and A. Regev, *Hook Young diagrams with applications to combinatorics and to representations of Lie superalgebras*, Adv. in Math. **64**(1987), 118–175.
2. N. Bergeron and A. Garsia, *Sergeev's formula and the Littlewood-Richardson rule*, Linear and Multilinear Algebra **27**(1990), 79–100.
3. D. M. Bressoud and S.-Y. Wei, *Determinantal formulae for complete symmetric functions*, J. Combin. Theory Ser. A **60**(1992), 277–286.
4. I. Gessel and G. X. Viennot, *Determinants, paths, and plane partitions*, unpublished.
5. I. P. Goulden, *Directed graphs and the Jacobi-Trudi identity*, Canad. J. Math. **37**(1985), 1201–1210.
6. I. P. Goulden and C. Greene, *A new tableau representation for supersymmetric Schur functions*, J. Algebra, to appear.
7. J. van der Jeugt and V. Fack, *The Pragacz identity and a new algorithm for Littlewood-Richardson coefficients*, Comput. Math. Appl. **21**(1991), 39–47.
8. J. van der Jeugt, J. W. B. Hughes, R. C. King and J. Thierry-Mieg, *Character formulae for irreducible modules of the Lie superalgebra $sl(m/n)$* , J. Math. Phys. **31**(1990), 2278–2304.
9. I. G. Macdonald, *Symmetric Functions and Hall Polynomials*, Oxford Univ. Press, Oxford, 1979.
10. ———, *Notes on Schubert Polynomials*, Univ. du Québec à Montréal Press, Montréal, 1991.
11. ———, *Schur functions: Theme and Variations*, Actes 28e Séminaire Lotharingien, Publ. I.R.M.A. Strasbourg, 1992, 5–39.
12. N. Metropolis, G. Nicoletti and G. C. Rota, *A new class of symmetric functions*. In: Math. Analysis and Applications, pp. 563–575, Adv. in Math. Supplementary Studies 7B, Academic Press, New York, 1981.
13. P. Pragacz, *Algebro-geometric applications of Schur S- and Q- polynomials*. In: Topics in Invariant Theory—Séminaire d'Algèbre Dubreil-Malliavin 1989–1990, Lecture Notes in Math. **1478**, Springer-Verlag, New York, Berlin, 1991, 130–191.
14. P. Pragacz and A. Thorup, *On a Jacobi-Trudi identity for supersymmetric polynomials*, Adv. in Math. **95**(1992), 8–17.
15. M. Scheunert, *Casimir elements of Lie superalgebras*. In: Differential Geometric Methods in Math. Physics, Reidel, Dordrecht, 1984, 115–124.
16. M. L. Wachs, *Flagged Schur functions, Schubert polynomials, and symmetrizing operators*, J. Combin. Theory Ser. A **40**(1985), 276–289.

*Department of Combinatorics and Optimization
University of Waterloo
Waterloo, Ontario
N2L 3G1*

Current address for first author:
*Department of Mathematics and Statistics
University of Canterbury
Christchurch, New Zealand*