

Erratum

Spatial Sound Synthesis in Computer-Aided Composition – Erratum

MARLON SCHUMACHER and JEAN BRESSON

doi:10.1017/S1355771810000300, Published by Cambridge University Press 25 October 2010

Figure 5 on page 280 should be replaced with correct version below

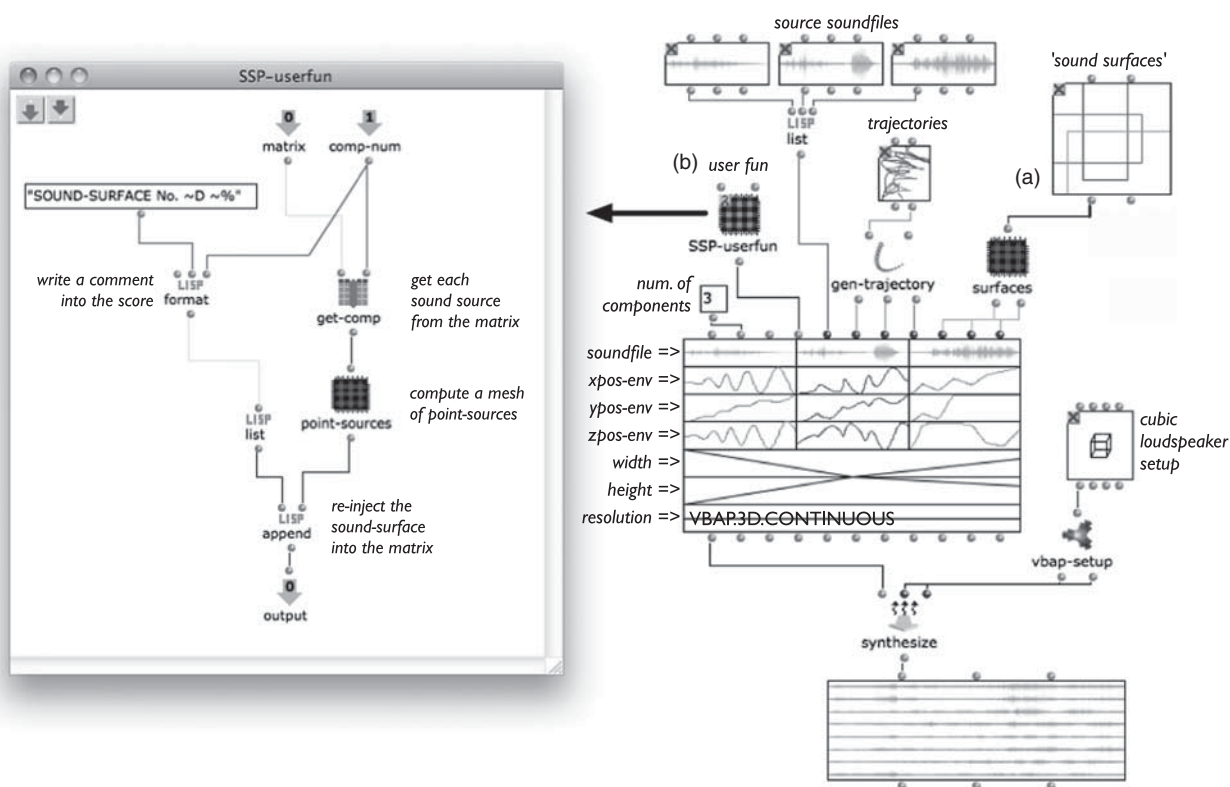

Figure 5.

In figure 10 on page 285, -“zpos-freqenc” should read ‘zpos-freqenv’

In the Introduction on page 271 the sentence:

The digital revolution of the music and media technologies since the early 1990s has stimulated an immense growth in the field of sound spatialisation technologies.

should read:

The digital revolution of music and media technologies since the early 1990s has stimulated an immense growth in the field of sound spatialisation technologies.

On page 272 (column 2, line 8)

...the grouping together of sound sources together and for these groups to be controlled individually.

should read:

...the grouping together of sound sources and for these groups to be controlled individually.

On page 273 (column 1, line 18)

Although the number of simultaneous sound sources and the temporal resolution of the control data were limited, as well as the number of simultaneous sound sources and the temporal resolution of the control-data, the ability ...

should read:

Although the temporal resolution of the control-data and the number of simultaneous sound sources were limited, the ability ...

On page 275 (column 1, line 7)

...score. this way irrelevant ...

should read:

...score. This way irrelevant ...

REFERENCE

Schumacher, M. and Bresson, J. 2010. Spatial Sound Synthesis in Computer-Aided Composition. doi:10.1017/S1355771810000300. *Organised Sound* **15**(3): 271–89.