

THE MULTI FREQUENCY FRONT END: A NEW TYPE OF FRONT END FOR THE WESTERBORK SYNTHESIS RADIO TELESCOPE

G.H.TAN

Netherlands Foundation for Research in Astronomy, P.O.Box 2, 7990 AA Dwingeloo, The Netherlands

ABSTRACT The Westerbork Synthesis Radio Telescope will be equipped with new front ends. These front ends will cover 8 frequency bands in the range from 250 MHz to 8.6 GHz. For the frequency bands above 1.2 GHz the sensitivity of the instrument will be drastically improved. Two independent local oscillator systems make it possible to observe in two frequency bands simultaneously.

INTRODUCTION

The Westerbork Synthesis Radio Telescope is one of the leading radio astronomical instruments in the world. Since the operations started in 1970 numerous modifications have been made to improve and extend the instrument (Baars *et al*, 1973)(Casse *et al*, 1982). This decade another major upgrade will be made on the WSRT, among others front ends, IF-system, correlator and control computers will be replaced. This paper describes the proposed new Multi Frequency Front Ends which will be added to the system in the first half of the 1990's. These new front ends will have more frequency bands than presently in use, instantaneous available in a compact package mounted at the focal point of the parabolic antennas. The user can choose between eight frequency bands in the range from 250 MHz to 8600 MHz. Some feed-arrangements and two independent local oscillator systems make it possible to observe in two frequency bands simultaneously. Also a large improvement will be made in the noise temperature of the front ends due to the use of cryogenically cooled amplifiers equipped with High Electron Mobility Transistors. Overall system temperatures range from 27 K for the 21 cm band to 84 K at 3.6 cm. For each frequency band two linear or circular polarized orthogonal channels are available making it possible to measure the 4 Stokes parameters.

SPECIFICATIONS

Probably the most interesting specifications from a user's point of view are the frequency coverage of the MFFE and the ability the change rapidly between frequency bands. The frequency bands covered by the new front ends are extended compared to the presently used front ends and more important

four frequency bands are added which are new for the WSRT. Table I shows the frequency spectrum covered by the Multi Frequency Front Ends with the properties to match for each band. Also shown is the theoretical r.m.s continuum sensitivity based on the system temperatures and the maximum MFFE bandwidth for the various wavelengths.

TABLE I WSRT Multi Frequency Front End Specifications and the resulting r.m.s. continuum sensitivity for 12 hours observation

λ	MHz	T_{sys}	BW	sensitivity
92 cm	320-330	120 K	10 MHz	0.2 mJy
49 cm	607-610	100 K	10 MHz	0.2 mJy
21 cm	1200-1450	27 K	160 MHz	0.01 mJy
18 cm	1590-1750	26 K	160 MHz	0.01 mJy
13 cm	2215-2375	52 K	160 MHz	0.02 mJy
6 cm	4770-5020	53 K	160 MHz	0.03 mJy
3.6 cm	8150-8650	84 K	160 MHz	0.05 mJy
UHF low	250-460	< 300 K	10 MHz	0.5 mJy
UHF high	700-1200	< 180 K	10 MHz	0.3 mJy

It is possible to observe in two frequency bands simultaneously but due to limitations in the mechanical construction it is not possible to have all combinations of the frequency bands shown in table I. The possible combinations are: 92 cm / 3.6 cm, 13 cm / 3.6 cm, 49 cm / 6 cm, UHF low / 3.6 cm, UHF low / 6 cm, UHF low / 18 cm, UHF low / 21 cm. However, full use of dual band observations will only be possible in conjunction with the projected new back end receiver of the WSRT.

CONSTRUCTION

Mechanical Construction

Figure 1 shows a cross section of the MFFE mounted in the front end box. The various feed systems can be seen together with the cryostat on which they are mounted (with the exception of the UHF-low feed). By rotating the cryostat around an axis perpendicular to the dotted axes the various feeds can be placed in the focal point (indicated by F) of the primary paraboloid.

Feeds

The front end uses five feed systems as can be seen in figure 1. The feeds for both UHF bands are made up of a pair of folded dipoles. These antennas give a reasonable performance over about an octave although they are not suited for polarization measurements. A single corrugated horn is used for 21 cm and 18 cm bands. A coaxial feed is used for the 49 cm, inside this feed another

corrugated horn is mounted covering the 6 cm band (Jeuken *et al*, 1972). A similar arrangement is used for a feed combining 92 cm, 13 cm and 3.6 cm.

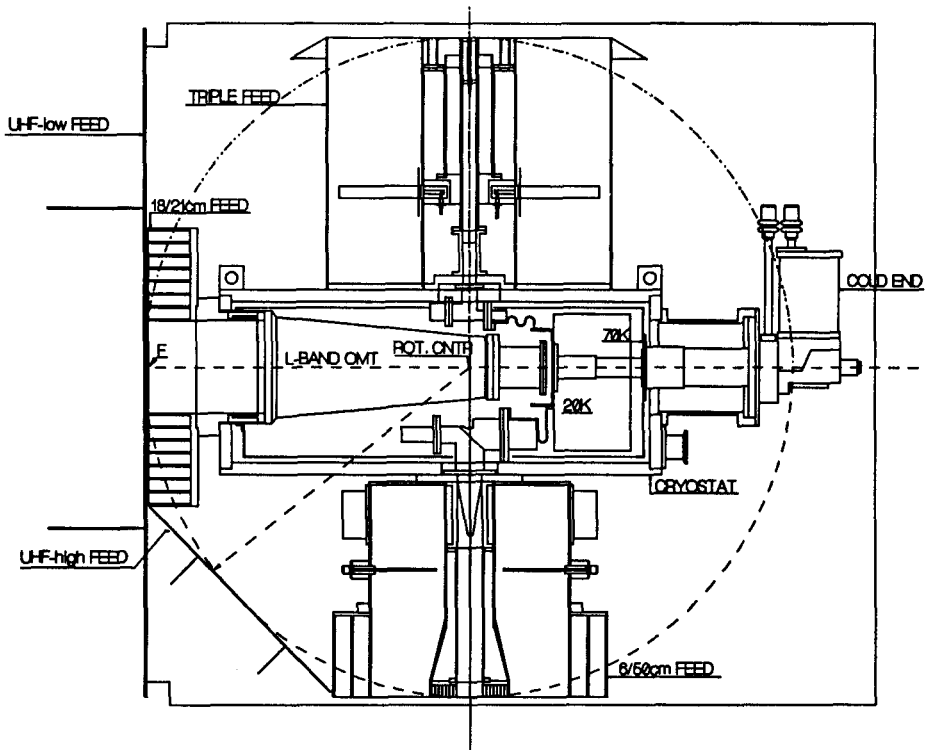

Fig. 1. MFFE cross section, showing feed systems

Electrical Systems

The front end is basically a double heterodyne, dual orthogonal polarization receiver. The principal polarization of the feed systems is linear. Figure 2. shows a simplified electrical lay-out. For the sake of clearness the dual orthogonal channels are not shown separately.

Incoming RF signals are amplified by one of the low noise amplifiers, filtered and converted to a first IF band at a center frequency of 1 GHz. For frequencies above 1.2 GHz the amplifiers are cooled to a temperature of approximately 20 K to reduce their noise contribution. The first local oscillator signal is generated by one of the two synthesizers. These synthesizers use YIG-tuned oscillators, which are phase locked to a very stable central frequency standard. After amplification and filtering in the first IF system the signals are converted to a second IF band with a center frequency of 100 MHz and send to the back end using coaxial cables. A fixed oscillator at 900 MHz, locked to the central frequency standard, drives the mixers between first and second

IF systems. A small computer system, not shown in figure 2, controls and monitors the front end.

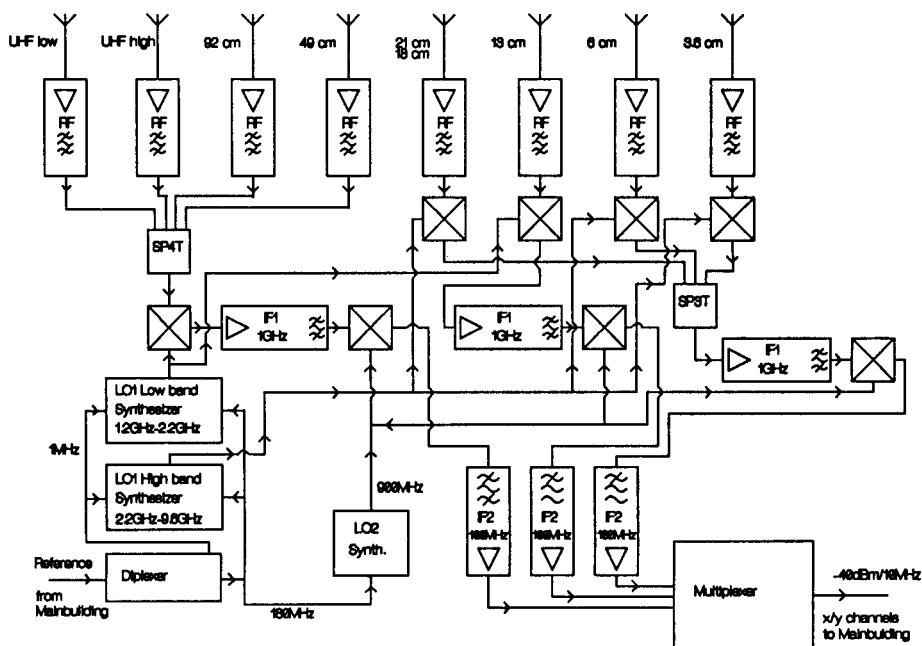

Fig. 2. Electrical lay-out of the Multi Frequency Front End

MFFE PROTOTYPE

The actual start of the MFFE project was in 1987 with the beginning of a feasibility study on the design of the new front end type. This study was completed in 1989 and the results have been published (Tan 1990). The next phase of the project was the construction of a single prototype MFFE and this started already last year. At present we are still in this prototype phase and it is planned to finish it next year, 1991, when this first MFFE will be ready for testing at the WSRT.

REFERENCES

- Baars, J. W. M. *et al*, 1973, *Proc. IEEE*, **61**, p. 1258
 Casse, J. L. *et al*, 1982, *IEEE Trans. Microwave Theory Tech.*, **MTT-30**, p. 201
 Jeuken, M. E. J. *et al*, 1972, *NTZ*, **8**, p. 374
 Tan, G. H., 1990, *N.F.R.A. note* **555**

Masato Ishiguro: Do you have a problem of interference or cross-talk between front ends?

G. H. Tan: We don't have a complete front end yet, so we are not able to test if there are any problems with interference inside or between front ends. However, we are aware of this problem and try to do as much as possible now in the design of the various subsystems. Some measures we are using to fight EMI are using milled housings with EMI-gaskets, extensive filtering of signal lines coming out of the housing and avoiding the use of switched power supplies.