

The Effects of Local Cooling on Canine Spinal Cord Blood Flow

Robert R. Hansebout, R. Neil Lamont, and M. Venkatraya Kamath

ABSTRACT: The internal spinal cord blood flow was measured in dogs at the site of local cooling using hydrogen polarography. Blood flow decreased to 50% of the normothermic values during cooling of the cord to a central temperature of 16 degrees Celsius. Upon cessation of cooling internal blood flow rapidly returned to normal values. Implications of this finding for the treatment of spinal cord injury are discussed.

RÉSUMÉ: Les résultats de refroidissement local sur l'écoulement sanguin dans la moelle épinière chez le chien Nous avons mesuré l'écoulement sanguin dans la moelle épinière chez des chiens à l'endroit de refroidissement local en employant la polarographie à l'hydrogène. L'écoulement sanguin diminua à 50 pourcent du niveau normothermique durant le refroidissement de la moelle épinière jusqu'à une température centrale de 16°C. Au moment de la cessation de refroidissement l'écoulement sanguin interne revient rapidement aux niveaux normaux. On discute les implications de cette donnée pour le traitement de blessures à la moelle épinière.

Can. J. Neurol. Sci. 1985; 12:83-87

Localized spinal cord cooling has been demonstrated to improve functional recovery after cord injury in animal experiments and human trials.¹ Cooling has been found to be most beneficial if instituted within four hours after injury.² The means by which cooling affects the pathogenesis has not been clearly delineated. The importance of ischemia in the pathogenesis of spinal cord injury (SCI) is controversial.^{3, 4, 5} Thus it would be of interest to determine if cooling alters spinal cord blood flow (SCBF). Previous work in this area consists of two papers which are contradictory, with one report indicating increased SCBF during local cord cooling⁶ and the other showing a decreased cerebral blood flow during whole body hypothermia.⁷

The cooling method employed here was that used in our previous SCI studies.^{2, 8} The effect of localized cooling on SCBF was measured by hydrogen polarography.^{9, 10} In addition to indicating tissue perfusion, this method permits serial SCBF measurements from the same site thus enabling the use of the SCBF value before cooling as a control.

MATERIALS AND METHODS

Surgical procedure

Five mongrel dogs of either sex with an average weight of 20 kg, were anesthetized with pentobarbital (30 mg/kg) and

maintained with pentobarbital. After an intravenous line was established using normal saline, each dog was intubated. A central arterial line was inserted into the left femoral artery for monitoring of arterial blood pressure and sampling of blood for gases and pH determinations.

Burr-hole laminectomies were performed at T-12, T-13, and L-1 vertebral levels. The left pedicle of T-13 was exposed and partially removed to expose the lateral aspect of the dura for placement of hydrogen polarograph (platinum) electrodes. The spinous processes at T-11 and L-2 were clamped in a frame to allow suspension of the entire animal. A 5 mm durotomy was made to expose the lateral aspect of the spinal cord. A single pial puncture was made using a 26 gauge needle. Two platinum electrodes with tips 1 mm apart were guided into the puncture site using a micromanipulator (saddle sites) (Fig. 1). No haemorrhage resulted from this procedure. These electrodes were advanced to approximately the midline of the cord. Next, a cooling saddle of previously reported design was positioned over the dorsal dura at T-13.⁸ A thermocouple (diameter 0.01 inch, T-type, Copper/Constantan, High Temperature Instruments Corp., West Conshohocken, PA) was inserted through the durotomy directly under the saddle in mid horizontal plane and advanced to about the midline. Platinum electrodes were also placed in the midline dorsal aspect of the cord at T-12 and L-1 through 26 gauge needle tracks (control sites). These were

From the Departments of Surgery and Neurosciences, McMaster University, Hamilton.

Received October 18, 1984. Accepted in revised form March 22, 1985.

Reprint requests to: Robert R. Hansebout, M.D., Department of Surgery, St. Joseph's Hospital, 50 Charlton Ave., E., Hamilton, Ontario, Canada L8N 4A6

advanced to a depth of about 3 mm. The wound was then filled with mineral oil to prevent tissue desiccation and diffusion of hydrogen. These procedures took between 4 to 5 hours.

The position of each electrode was not verified histologically. There was no subsequent manipulation of electrodes throughout the experiment.

Cooling technique

Local cord cooling was achieved by using a silastic saddle previously described.⁸ This cooling method enabled examination of the effects of cooling only, separate from those of perfusion. The coolant was ice water circulated at a rate sufficient to maintain a saddle temperature of approximately 3°C. Cord temperature was measured under the saddle by the above mentioned thermocouple connected to a digital thermometer readout (Newport Model 850, Newport Laboratories Inc.).

Blood flow measurement

The blood flow was measured using Fick's principle by the hydrogen clearance technique.^{9, 10} The technical improvements of Senter et al.¹¹ were utilized with modifications in the electrode tip etching procedure and in spinal immobilization technique to reduce respiratory artifact. The electrodes were made from Teflon coated platinum-iridium wire 150 microns in diameter (Medwire Corp., Vernon, NY). Two mm of exposed wire were etched to a 10 micron tip by passing 75-100 milliamps alternating current in 50% KCN, 30% KOH as described by Geddes.¹² The four platinum electrodes were connected to a hydrogen polarograph (Willis Medical Electronics, Washington D. C.). The reference voltage was set to 650 mV. The polarograph was connected to a four-channel analog to digital converter interfaced with an Apple-IIe computer.

Hydrogen was administered via a closed circuit anaesthetic gas machine fitted with a carbon dioxide scrubber in an approximate 50:50::H2:O2 mixture until the output voltage of the polarograph reached a plateau. The animal was allowed to breathe freely via the endotracheal tube. Only occasional ventilatory assistance was needed to maintain blood gas values within a normal range with the exception of higher than normal

pO2 values. This phase of the experiment took about 10-15 minutes at which time the dog resumed breathing room air.

The decaying electrode voltages (polarograph readings) were sampled every 15 seconds (sampling aperture of 70 microseconds) until the level of polarograph reading reached less than 10% of the peak value (Fig. 2). The data were stored on diskettes. A linear regression was performed on the logarithm of the data from each electrode and a best-fitting straight line was computed using a BASIC program. If the correlation was less than 98%, the datum was rejected. The blood flow was calculated from the slope of the curve which is proportional to the time taken for the polarograph reading to decay to half its plateau level (Fig. 2). The slope of this line is $k = 0.693/T_{-half}$ where T_{-half} is the time taken for the voltage value to fall to half. The flow $F = P \times k \times 100$ where 'P' is the tissue/blood partition coefficient which is assumed to be unity for hydrogen. The factor 100 in the above equation converts the flow units to ml of blood flow /100 gm of tissue/min.¹⁰

The functional characteristics of the platinum electrode during hypothermia have not been reported. The electrode reaction is $H_2 \rightarrow 2H^+ + 2e^-$. The electrode voltage is determined by the Nernst equation:

$$\text{electrode voltage} = \frac{RT}{ZnF} \ln \frac{aH^+}{aH_2}$$

Since R, Z, n, and F are all constants, the only variables are T (absolute temperature), aH⁺ (activity of hydrogen ion) and aH₂ (activity of hydrogen molecule) which are approximated by concentration of H⁺ and partial pressure of H₂. The effect of temperature on electrode function was examined using a fixed amount of inhaled hydrogen, allowing the polarograph reading to reach a plateau, then cooling and rewarming the cord.

Statistical significance of changes in SCBF were evaluated using Student's 't' test at p < 0.01.

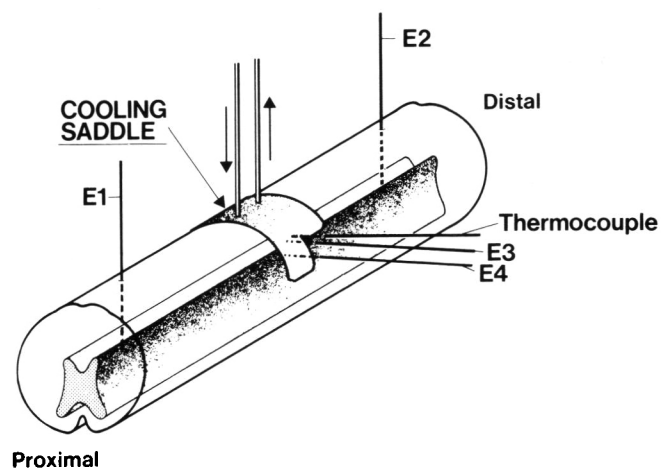

Figure 1 — Placement of electrodes, thermocouple and cooling saddle. Electrode positions were: electrodes 1 and 2, control sites; electrodes 3 and 4, saddle sites.

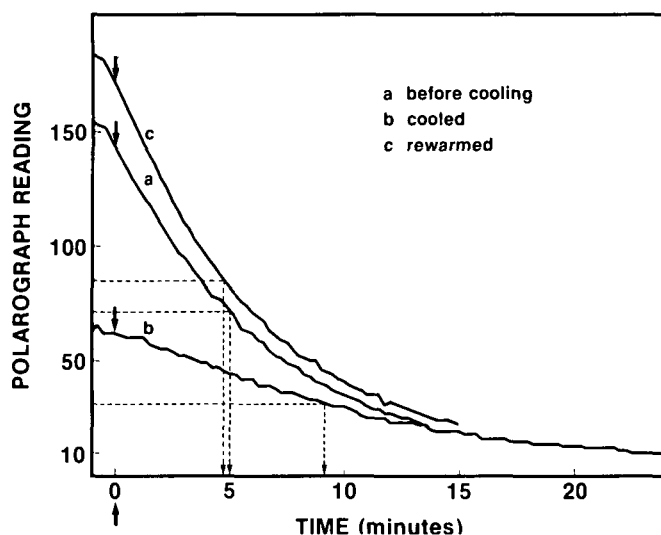

Figure 2 — Polarograph reading in arbitrary voltage units as a function of time after discontinuation of H2:O2 at time 0. Curves a, b, and c were all recorded from electrode 3 of experiment 14. Readings were taken every 15 seconds.

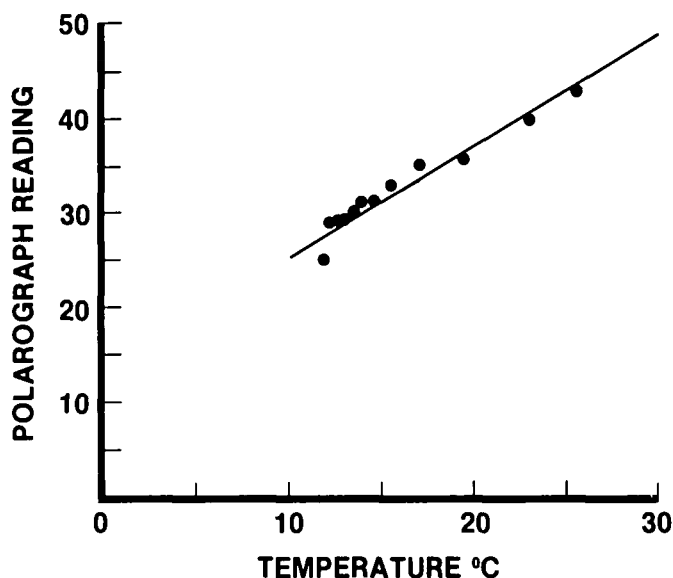

Figure 3 — Polarograph reading in arbitrary voltage units as a function of cord temperature. Readings were recorded from a saddle site (electrode 3) every 15 seconds while cooling the cord during one trial. The ambient tissue hydrogen level was kept constant by maintaining the dog on the closed respiratory circuit during the trial (see Methods). The line plotted is a linear regression of $y = 13.7 + 1.18x$ with $r = 0.99$.

Table 1: Initial spinal cord blood flow (SCBF) in ml/100 gm tissue/minute as measured by hydrogen polarography. (see Methods).

Dog Number	Number of trials	SCBF (Mean ± SD) Electrode Position			
		1	2	3	4
9	2	9.81 ± 0.79	—	12.91 ± 1.35	13.31 ± 0.70
11	2	—	—	9.10 ± 0.36	10.19 ± 0.45
12	3	7.65 ± 1.75	8.11 ± 0.81	12.89 ± 2.01	15.85 ± 4.09
14	2	6.32 ± 0.23	9.01 ± 0.89	13.82 ± 0.16	12.76 ± 0.07
17	2	7.88 ± 0.29	6.67 ± 0.05	10.63 ± 0.47	8.51 ± 0.09

RESULTS

The relationship between cord temperature and electrode potential was found to be linear ($y = 13.7 + 1.18x$), at a 99% confidence level (Fig. 3). The Nernst equation predicts that if temperature affects activities of H⁺ and H₂ the voltage will vary logarithmically with temperature. If there is no effect on activities and only the absolute temperature term (T) is changed, the voltage will vary linearly with temperature. Thus the observed variations in the voltage with cooling are a result of decreased temperature rather than different lipid partitioning of hydrogen at lower temperature.

A baseline blood flow value for the cord at each electrode position in each dog was determined by averaging 2 or 3 consecutive trial values at normal temperature. These blood flow values are tabulated in Table 1. Reproducibility of SCBF values from the initial trials served as a verification for the stability of electrode placement.

The SCBF values from Table 1 were used as 100% blood flow values for each electrode location in each animal. The average absolute blood flow values obtained during cooling and after

rewarming are expressed in Fig. 4 as a percentage of the initial SCBF values of Table 1. The SCBF decreased by an average of 50% at the saddle sites during cooling and returned to the original blood flow levels on rewarming as the results demonstrate (Fig. 4). The SCBF decrease during cooling was significant ($p < 0.01$), while the average flow following rewarming was indistinguishable from the original average flow value. This decrease indicates a profound effect on local SCBF alone. The SCBF at proximal and distal control sites was not significantly affected during cooling or rewarming at the saddle sites. During preliminary experiments the temperatures at these control sites was found to remain normothermic.

The degree of cooling effected was an average of 18.5°C lower than initial temperature with the rewarmed temperature returning to within 0.8°C of original temperature. Actual temperatures achieved in the spinal cord were in the neighbourhood of 16°C.

DISCUSSION

The absolute SCBF values reported in Table 1 are comparable to those reported by Griffiths and Rowan,¹³ Kobrine et al.¹⁴ and Senter et al.¹¹

The polarograph voltage reading plateau was found to be a function of the amount of hydrogen in the gas machine circuit

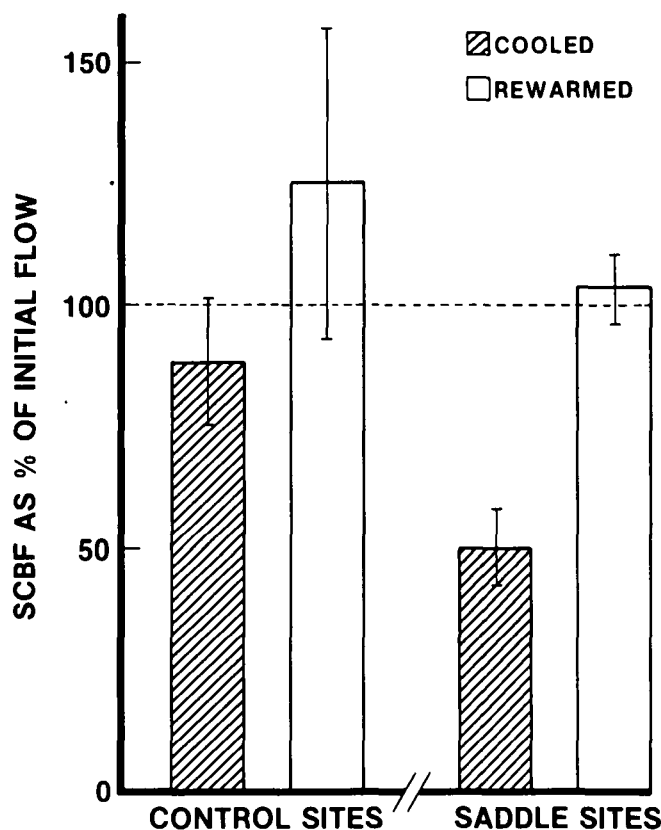

Figure 4 — Spinal cord blood flow (SCBF) as percentage of initial flow during cooling and subsequent rewarming to original temperature. Control sites and saddle sites are those delineated in Fig. 1. Initial flow values for each electrode are presented in Table 1. The percentages plotted are a mean ± s. d. of results in 5 dogs, each with two trials cooled and two trials rewarmed.

and of the temperature of the tissue around the electrode. The curves 'a' and 'c' in Fig. 2 demonstrate the difference in plateau achieved in two trials at the same temperature. This difference can be accounted for by different amounts of hydrogen in the animal's ventilatory circuit during each trial. However, the half-times and therefore blood flows of trials 'a' and 'c' are essentially the same. Curve 'b', obtained during cooling, has a markedly lower plateau value as well as a longer half-time. The longer half-time indicates a lower blood flow value. The lower plateau is the result of electrode characteristics as explained above. Thus, the measured voltage changes at the site of cooling indicate an actual reduction in blood flow and not the effects of partitioning of dissolved gases in the tissues at lower temperatures. Similar results are reported by Meyer and Hunter⁷ for oxygen electrodes used under hypothermic conditions. Consequently, this validates our measurement of blood flow during hypothermia using hydrogen polarography.

Our finding of a decreased SCBF during hypothermia corroborates reports by others^{7, 15} of a decrease in cerebral blood flow during hypothermia. However, whole body hypothermia (30°C) was used in those experiments rather than the low localized temperatures achieved in the current study. With whole body cooling, systemic effects cannot be ruled out.

What happens to the blood flow normally present in the region of the cord subjected to cooling as proximal and distal sites have normal SCBF? At least two possibilities can be considered. The hydrogen clearance method measures tissue perfusion within the cord rather than surface blood flow. It is possible that blood normally passing through the central part of the cord is shunted through large surface vessels under the cooled area. Zielonka et al.⁶ reported an increased flow in the intersegmental (surface) vessels of a cooled segment of spinal cord after 5 minutes of hypothermia. Their finding could be the result of increased shunting of blood past the cooled area avoiding deep capillary beds. Temperature can affect blood vessel calibre differently depending upon the location of the vessel.¹⁶ Thus surface vessels of the cord could dilate while the internal vessels constrict in response to hypothermia. This explanation would reconcile our observed 50% SCBF decrease with Zielonka et al.'s noted increased flow in surface vessels. A complete blockade

of flow through the cooled saddle site might be expected to decrease blood flow in at least one control site.

Zielonka et al.⁶ also noted an increased local tissue perfusion after 60 minutes of hypothermia which they attribute to a loss of autoregulation. In the present study, the second SCBF measurement during cooling was made at least 60 minutes after hypothermia had been instituted. An identical 50% decrease was again noted. The discrepancy between these studies could be due to: the difference in the method of blood flow measurement (Zielonka used Thioflavin S), the difference in cooling technique (Zielonka used cooled saline perfusion through durotomy), or more remotely, the difference in animal species (Zielonka used cats).

Meyer and Hunter⁷ reported that the calibre of brain surface vessels reduced by as much as 50% when cooled below 30°C. If the same occurs in cord surface vessels then a more likely explanation for our findings is that all cord vessels constrict upon cooling. Thus the extra blood may be shunted away from the cooled segment by collateral flow as schematically represented in Fig. 5. The hatched area represents the tissue perfusion or SCBF which is reduced in the cooled cord under the saddle. Proximally blood is directed retrograde away from the cooled segment through the first available radicular arteries. Distally blood is directed toward the cord via the radicular arteries to augment the blood flow to normal levels in the adjoining normothermic segment. Whether the blood normally flowing to the constricted central vessels is shunted past the cooled core by surface vessels or radicular vessels as illustrated in Fig. 5 is unknown. We were unable to confirm this as the present design precludes the observation of surface vessels.

Although this type of localized perfusion reduction could be mediated through an autonomic neural mechanism, it is probable that increased blood viscosity or a direct effect on vascular smooth muscle are more likely mechanisms for the decreased blood flow. We are currently studying the effect of cooling on smooth muscle. If this direct smooth muscle action is the result of a membrane effect such as a decrease in fluidity which in turn affects the ion conductances or some other function, then one would expect the membrane effect to be generalized to all cells and subcellular organelles being cooled. Astrup¹⁷ notes that hypothermia reduces the consumption of oxygen and glucose in the brain affording clinical protection, but that a similar degree of barbiturate metabolic reduction does not give protection. He concludes that hypothermia must be protecting the tissue by "membrane stabilization."

Scuotto et al.¹⁸ found that edema started within an hour after impact injury and then peaked between the 4th and 6th hour after the injury, suggesting a rapid onset of vasogenic edema. Kobrine et al.¹⁹ found that after a significant cord injury, blood flow in the gray matter was markedly reduced while flow in the white matter actually increased. If the cord is cooled for four hours during the first few hours after injury this tends to preserve cord function.² In light of these findings we postulate that the decreased blood flow caused by cooling at the site of injury tends to prevent the outpouring of edema fluid and other toxic factors from the injured vessels, thus preserving cord function. However, if the injured cord is cooled for a long time (18 hours) the beneficial effects of cooling are obviated.² This may be the result of an ischemic situation perpetrated by prolonged cooling. Thus, our finding of decreased SCBF in the locally cooled spinal cord may have some clinical relevance.

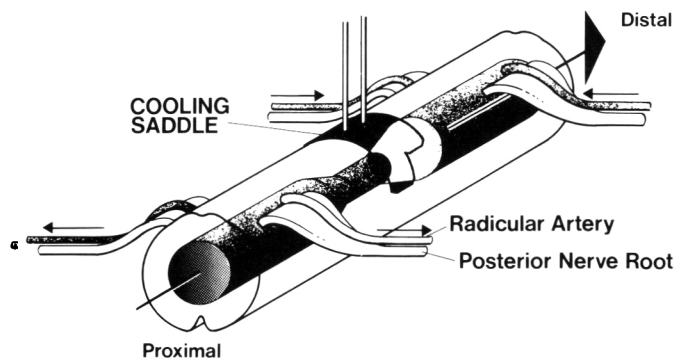

Figure 5 — Schematic representation of SCBF during local cord cooling. Dark central cylinder represents blood flow rate with sharply reduced flow under cooling saddle. Blood in proximal radicular arteries flows in retrograde fashion due to distal vascular resistance. Distally, blood flow is augmented to usual rates by normal flow through distal radicular arteries.

ACKNOWLEDGEMENTS

This work was supported by funds from the Medical Research Council of Canada (MA 3988).

REFERENCES

1. Hansebout R R A comprehensive review of methods of improving cord recovery after acute spinal cord injury. In: Tator C H, ed. *Early Management of Acute Spinal Cord Injury*. Semin Neurol Surg, New York: Raven Press, 1982; pp 181-196.
2. Wells J D, Hansebout R R Local hypothermia in experimental spinal cord trauma. *Surg Neurol* 1978; 10: 200-204.
3. Bingham W G, Goldman H, Friedman S J, et al. Blood flow in normal and injured monkey spinal cord. *J Neurosurg* 1975; 43: 162-171.
4. Kobrine A I, Evans D E, Rizzoli H Correlation of spinal cord blood flow and function in experimental compression. *Surg Neurol* 1978; 10: 54-59.
5. Tator C H Acute spinal cord injury: A review of recent studies of treatment and pathophysiology. *Can Med Assoc J* 1972; 107: 143-150.
6. Zielonka J S, Wagner F C, Dohrmann G J Alterations in spinal cord blood flow during local hypothermia. *Surg Forum* 1974; 25: 434-435.
7. Meyer J D, Hunter J *Effects of hypothermia on local blood flow and metabolism during cerebral ischemia and hypoxia*. *J Neurosurg* 1957; 14: 210-227.
8. Romero-Sierra C, Hansebout R, Sierhuis A, et al. A new method for localised spinal-cord cooling. *Med Biol Eng* 1974; 12: 188-193.
9. Aukland K Hydrogen polarography in measurement of local blood flow: theoretical and empirical basis. *Acta Neurol Scand [Suppl]* 1965; 14: 42-46.
10. Aukland K, Bower B F, Berliner R W *Measurement of local blood flow with hydrogen gas*. *Circ Res* 1964; 14: 164-187.
11. Senter H J, Burgess D H, Metzler J An improved technique for measurement of spinal cord blood flow. *Brain Res* 1978; 149: 197-203.
12. Geddes L A *Electrodes and the Measurement of Bioelectric Events*. Toronto: Wiley & Sons Inc., 1972; pp 139-140.
13. Griffiths I R, Rowan J O Spinal cord blood flow measured by a hydrogen clearance technique. *J Neurol Sci* 1975; 26: 529-544.
14. Kobrine A I, Doyle T F, Martins A N Spinal cord blood flow in the rhesus monkey by the hydrogen clearance method. *Surg Neurol* 1974; 2: 197-200.
15. Rosomoff H L Protective effects of hypothermia against pathological processes of the nervous system. *Ann Ny Acad Sci* 1959; 80: 475-486.
16. Janssens W J, Vanhoutte P M Instantaneous changes of alpha-adrenoceptor affinity caused by moderate cooling in canine cutaneous veins. *Am J Physiol* 1978; 234: H330-H337.
17. Astrup J Energy-requiring cell functions in the ischemic brain. *J Neurosurg* 1982; 56: 482-497.
18. Scuotto A, Borriello R, Paggio G Valuation of some biological parameters in acute spinal cord trauma: experimental study. Presented at *Seminar On Spinal Cord Reconstruction*, Auditorium Museo di Capodimonte, Naples, Italy, October 21, 1983.
19. Kobrine A I, Doyle T F, Martins A N Local spinal cord blood flow in experimental traumatic myelopathy. *J Neurosurg* 1975; 42: 144-149.