Proteinuria is associated with persistence of antibody to streptococcal M protein in Aboriginal Australians

A. M. GOODFELLOW, W. E. HOY, K. S. SRIPRAKASH, M. J. DALY*,
M. P. REEVE* AND J. D. MATHEWS†

Menzies School of Health Research, PO Box 41096, Casuarina NT, Australia 0810

(Accepted 26 August 1998)

SUMMARY

Aboriginal communities in Northern Australia with high rates of group A streptococcal (GAS) skin infection in childhood also have high rates of renal failure in adult life. In a cross-sectional study of one such high risk community, albuminuria was used as a marker of renal disease. The prevalence of albuminuria increased from 0/52 in subjects aged 10–19 years to 10/29 (32.9%) in those aged 50 or more ($P < 0.001$). Antibodies to streptococcal M protein, markers of past GAS infection, were present in 48/52 (92%) at ages 10–19 years, 16/32 (50%) at ages 30–39, and 20/29 (69%) in those aged 50 or more. After allowing for the age-dependencies of albuminuria and of M protein antibodies ($P < 0.001$) albuminuria was significantly associated with M protein antibodies ($P < 0.01$). Thus, 72% of adults aged 30 or more with M protein antibodies also had albuminuria, compared with only 21% of those who were seronegative. More detailed modelling suggested that although most Aboriginal people in this community developed M protein antibodies following GAS infection in childhood, the development of proteinuria was associated with the persistence of such seropositivity into adult life. The models predicted that proteinuria developed at a mean age of 30 years in seropositive persons, at 45 years in seronegative persons who were overweight, and at 62 years in seronegative persons of normal weight. We demonstrated a clear association between evidence of childhood GAS infection and individual risk of proteinuria in adult life. This study provided a strong rationale for prevention of renal disease through the more effective control of GAS skin infections in childhood and through the prevention of obesity in adult life.

INTRODUCTION

Group A streptococcal infections of the throat or skin in childhood can be followed by acute glomerulonephritis, particularly in poor social circumstances where streptococcal infections are endemic [1]. In affluent populations, acute post-streptococcal glomerulonephritis (APSGN) has virtually dis-

appeared [2] since the 1950s following improvements in living conditions and availability of penicillin; deaths due to chronic renal failure have also declined markedly [3].

Follow-up studies of children with APSGN suggest that the outcome is usually benign [4, 5], with progression to sub-acute or chronic glomerulonephritis only in a minority [6], whereas APSGN in older subjects is more likely to progress [7] or to be followed by diffuse mesangial proliferative glomerulonephritis with albuminuria [8]. Many Aboriginal

* Present address: Whitehead Institute for Biomedical Research, 9 Cambridge Centre, Cambridge, MA, 02142, USA.

† Author for correspondence.

Australians still live in poor social circumstances, with inadequate health services [9, 10]. Consequently, there are high rates of scabies and endemic skin sores associated with GAS infection [10, 11]. Skin sores are present in 10–60% of Aboriginal children in school surveys in Northern Australia and most lesions are infected with GAS [10–12]; higher rates of GAS carriage at any one time are associated with larger numbers of antigenically distinct strains of GAS [12, 13].

Very high rates of proteinuria and renal failure are also found in Aboriginal communities in the Northern Territory of Australia [10, 14, 15]. Proteinuria occurs in a minority of adolescents [10] and was noted in 50% of adults in an island community [14], where 2% of adults are currently on haemodialysis [15]. Proteinuria is familial, and often associated with obesity, hypertension and with non-insulin dependent diabetes mellitus (NIDDM) in a minority [14, 15]. The incidence of end-stage renal failure (ESRF) is increased 60–100 fold in this Aboriginal community compared with rates for Australia as a whole [14, 15]. Biopsies from Aboriginal patients show diffuse mesangial glomerulonephritis, glomerulomegaly and/or diabetic nephropathy [15].

Thus in Aboriginal populations subject to endemic GAS infection [10–13], with occasional epidemics of APSGN [16, 17], and with a high frequency of chronic renal disease [14, 15] there could be a causal link between persistent or recurrent GAS infection in childhood and progressive glomerulonephritis in later life.

Antibodies to GAS M proteins develop within months of GAS infection, confer M-type specific protection [18, 19] and persist for years [20]. Raised levels of M protein antibodies have been reported in patients with chronic glomerulonephritis from Japan [21]. To explore the relationship between M protein antibodies and renal disease we measured M protein antibodies and proteinuria amongst participants in a prospective health study in an Aboriginal community at high risk of renal disease.

METHODS

Study population

The study population was Aboriginal people in the Tiwi Island community of Nguiu, Northern Australia, concerned about their high rates of renal failure [14, 15], participated in a prospective community

survey to describe proteinuria and its potential risk factors, to study the natural history of renal disease and to provide early treatment. Ethical approval was given by a committee working to National Health and Medical Research Council guidelines. Study details have been reported [22]. Briefly, without selecting for or against renal disease, adults and adolescents from the study population were invited to volunteer for a health screening examination. Measurements included: height, weight, the ratio of albumin to creatinine in urine, and serum antibodies to streptococcal M proteins.

The albumin to creatinine ratio

The albumin to creatinine ratio (ACR) was measured by standard methods [23] in a ‘clean catch’, random urine sample. ACR measurements are reliable and provide valid measurements of proteinuria when it is impractical to use 24 h collections of urine [24]. We defined: ‘probably normal’ as an ACR $< 3.4 \text{ g mol}^{-1}$; microalbuminuria as an ACR ≥ 3.4 but $< 34 \text{ g mol}^{-1}$; albuminuria as an ACR $\geq 34 \text{ g mol}^{-1}$. Proteinuria was defined as the presence of either microalbuminuria or albuminuria.

The Quetelet index

Quetelet index, as an index of obesity, was calculated as $\text{weight}/(\text{height})^2$ in units kg m^{-2} . For qualitative analyses an index greater than 25 kg m^{-2} was regarded as overweight.

Detection of M protein antibodies

Acid extracts of *Streptococcus pyogenes* were prepared from reference isolates of M1, M3, M4, M5, M6, M12, M14, M18, M24, M30, M49, M52, M53, M57, M59, M60 and M80. Total protein in each M protein extract [25] was adjusted to 1 mg/ml before use and tested by the slide method for Ouchterlony double diffusion [26]. Serum aliquots ($4 \mu\text{l}$) were placed in the central well of 1% immunodiffusion agarose (Biorad 170-3002) containing 3% polyethylene glycol 6000 (BDH), and $2 \mu\text{l}$ of each acid extract was placed in outer wells. After 16 h in a humidified chamber at room temperature, gels were washed, dried and stained with 0.5% Coomassie Brilliant Blue R-250. Precipitin bands were clearly discernible and were

distinct from the diffuse anti-group A carbohydrate precipitation reactions observed in a few serum samples; gels were read blind, and results recorded as positive or negative for each of the M protein extracts used. Because positive precipitin reactions were infrequent for individual M proteins, results were aggregated and M protein antibody status was regarded as positive if there was a precipitin reaction with at least one M protein. As a negative control, IgG antibody to recombinant human heat-shock protein (HSP-60) (Stress Gen, Canada SPP740) was measured by ELISA [27] in the same sera.

Data and statistical methods

Data on age, ACR, Quetelet index and M protein antibodies were available for the first 175 unselected subjects seen in the community survey. As there were no substantial differences between male and female subjects, results were not stratified by gender. The GLIM statistical package was used for log-linear and logistic regression models [28]. Using previously published methods for multi-stage modelling [29], we used these prevalence data to estimate rates for past acquisition and loss of antibodies to M protein, for development of overweight, and for acquisition of proteinuria in the presence and absence of M protein antibodies. The modelling approaches are explained in more detail in the appendix.

RESULTS

Albuminuria rates increased from 0/52 at ages 10–19 years to 10/29 (32.9%) at age 50 or more ($P < 0.001$, Table 1). Microalbuminuria also increased with age. The prevalence of M protein antibodies was highest (92%) at ages 10–19 but fell with age ($P < 0.001$). After allowing for the age dependence of both albuminuria and M proteins antibodies, subjects with albuminuria or microalbuminuria were significantly more likely to be seropositive ($\chi^2_{(2)} = 7.2$, $P < 0.03$ by log-linear modelling).

The association of proteinuria with M protein antibody status, age and obesity was explored in a logistic regression analysis (Table 2). The increasing probability of proteinuria with age, antibody status and overweight status is shown in Figure 1.

Figure 2 summarizes the transition-state model explaining the age distribution of proteinuria and seropositivity for the data in Table 1. In this model it

was assumed that after birth, young children were negative (N_1) for both antibodies and proteinuria, but that because of the ubiquity of GAS infection, children underwent antibody conversion to the state S . The estimated rate of seroconversion was $K_1 = 32.6\%$ per year, and the mean age of seroconversion was estimated to be $1/K_1 = 3.1$ years. After seroconversion, antibodies could be lost and subjects could become seronegative again (N_2) at an estimated rate of K_2 (2.5% per year). Alternatively subjects could develop ‘permanent’ antibodies (S_2) at a rate K_4 (3.8% per year). Proteinuria could develop by transition from the seronegative state N_2 to P at a rate K_3 (2.7% per year) or from the seropositive state S_2 to the state PS (proteinuria with seropositivity) at a rate K_5 (7.8% per year).

The conclusions from the model may be summarized in terms of the mean time in years to reach each of the states in Figure 2. The estimated low mean age for M protein antibody seroconversion ($1/K_1 = 3.1$ years), implied that most subjects seroconverted in childhood (Table 1). Thus seronegativity in adult life was explained in this model by subsequent loss of M protein antibodies, rather than by failure to seroconvert in childhood. The second inference was that the mean age of onset of proteinuria for those remaining seropositive was 31.6 years, compared with a mean age of onset of proteinuria of 55.5 years for those reverting to seronegative status (Fig. 2). The lower age of onset of proteinuria in subjects retaining M protein antibodies was significant ($\chi^2_{(1)} = 8.52$, $P < 0.005$). This suggested that the persistence of antibodies to GAS M proteins was a risk factor for the early onset of proteinuria in this population. In contrast, the presence of antibodies against HSP-60, measured as a negative control, was not correlated with proteinuria.

The added effect of becoming overweight on the acquisition of proteinuria was estimated in a separate model. Figure 3 shows that the predicted mean age of onset of proteinuria in seropositive subjects not overweight was 30.0 years, compared with 62.3 years for seronegative subjects who were not overweight. For overweight subjects the predicted mean age of onset of proteinuria was 29.3 years if seropositive and 45.0 years if seronegative. The differences attributable to seropositivity were highly significant ($\chi^2_{(2)} = 20.0$, $P < 0.001$), as were those due to overweight. Thus seropositivity for M protein antibodies was associated with an earlier onset of proteinuria regardless of whether the subject was overweight, whereas over-

Table 1. Numbers (%) of subjects with microalbuminuria or albuminuria and/or M protein antibodies by age

Age group (years)	Normal urine ACR < 3.4 g mol ⁻¹		Microalbuminuria 3.4 < ACR < 34 g mol ⁻¹		Albuminuria ACR > 34 g mol ⁻¹		All classes
	M ⁻ *	M ⁺	M ⁻	M ⁺	M ⁻	M ⁺	
10-19	4 (7.7)	41 (78.8)	1 (1.9)	6 (11.5)	0	0	52 (100%)
20-29	12 (29.3)	18 (43.9)	5 (12.2)	4 (9.8)	0	2 (4.9)	41 (100%)
30-39	8 (25.0)	4 (12.5)	4 (12.5)	6 (18.8)	4 (12.5)	6 (18.8)	32 (100%)
40-49	4 (19.0)	2 (9.5)	1 (4.8)	5 (23.8)	0	9 (42.9)	21 (100%)
50+	3 (10.3)	3 (10.3)	4 (13.8)	9 (31.0)	2 (6.9)	8 (26.0)	29 (100%)
All ages	31	68	15	30	6	25	175

* M⁻, no M protein antibodies detected; M⁺, antibodies to one or more M types detected.

Table 2. Regression analysis to predict proteinuria as a function of age, Quetelet index and presence of M antibodies

Predictor variable	Logistic regression co-efficient	Standard error of co-efficient	Statistical significance (backwards elimination)
Age (years)	0.07513	0.01416	$\chi^2_{(1)} = 36.74, P < 0.001$
Quetelet (kg m ⁻²)	0.1282	0.03845	$\chi^2_{(1)} = 12.10, P < 0.001$
M antibody (present)	0.9343	0.4237	$\chi^2_{(1)} = 5.12, P = 0.03$
Constant term	-6.1877	1.380	—

Probabilities of proteinuria estimated from this regression equation are plotted in Fig. 1 for various combinations of age, Quetelet index and M protein antibody status.

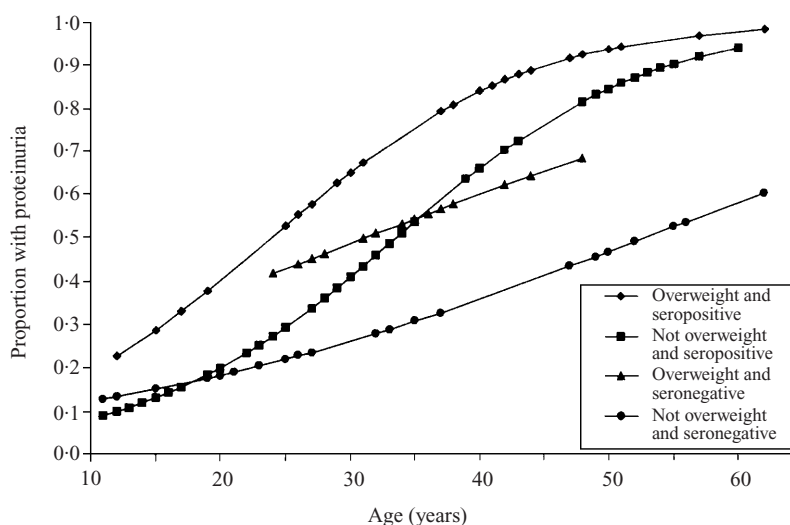

Fig. 1. Estimated probability of proteinuria by age, overweight status and M protein antibody status.

weight was associated with an earlier onset of proteinuria only in seronegative subjects.

DISCUSSION

High rates of renal disease in Aboriginal people in northern Australia invite comparison with rates in

other tropical populations, some forms of which are attributed to malaria, hepatitis B, schistosomiasis or other infections [30]. Malaria and schistosomiasis are absent from Northern Australia, and there is no association of proteinuria with hepatitis B infection status [31]. Despite the frequency of GAS skin infections in Aboriginal and tropical populations

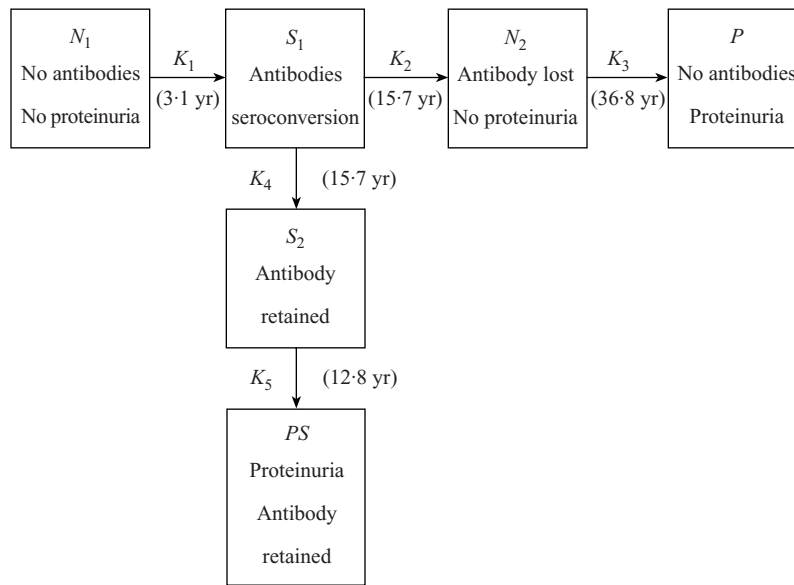

Maximum likelihood estimates of rate parameters for model in Fig. 2

Parameter	Process	Parameter estimate (S.E) (yr^{-1})	Mean time (yr) for process
K_1	$N_1 \longrightarrow S_1$	0.3264 (0.1549)	$\frac{1}{K_1} = 3.1$
K_2	$S_1 \longrightarrow N_2$	0.0252 (0.0061)	$\frac{1}{K_2 + K_4} = 15.7$
K_3	$N_2 \longrightarrow P$	0.0272 (0.0069)	$\frac{1}{K_3} = 36.8$
K_4	$S_1 \longrightarrow S_2$	0.0385 (0.0143)	$\frac{1}{K_2 + K_4} = 15.7$
K_5	$S_2 \longrightarrow PS$	0.0779 (0.0393)	$\frac{1}{K_5} = 12.8$

Log likelihood = -193.8743 for the full model.

For the data summarized here the best estimate for the mean age of developing proteinuria in those who stay seropositive is

$$\frac{1}{K_1} + \frac{1}{K_2 + K_4} + \frac{1}{K_3} = 31.6 \text{ years}$$

compared with an estimate of

$$\frac{1}{K_1} + \frac{1}{K_2 + K_4} + \frac{1}{K_5} = 55.5 \text{ years}$$

for the mean age of onset of proteinuria in those reverting to seronegative status. The significance of the difference between these estimates can be judged by constraining $K_3 = K_5$ in the above model. In the constrained model, the log-likelihood decreased to -198.1362, giving a

$$X^2_{(1)} = -2(-198.136 - (-193.874)) = 8.524, \quad P < 0.005$$

Fig. 2. Model for development of proteinuria (P) according to M protein antibody status (S).

[10–14, 16, 17, 30], there has been no consensus as to the importance of GAS in causing chronic renal disease [4–8, 10, 30].

The present study was initiated because of the high rates of both GAS infection [10–12, 16, 17] and chronic renal disease [14, 15] in Aboriginal com-

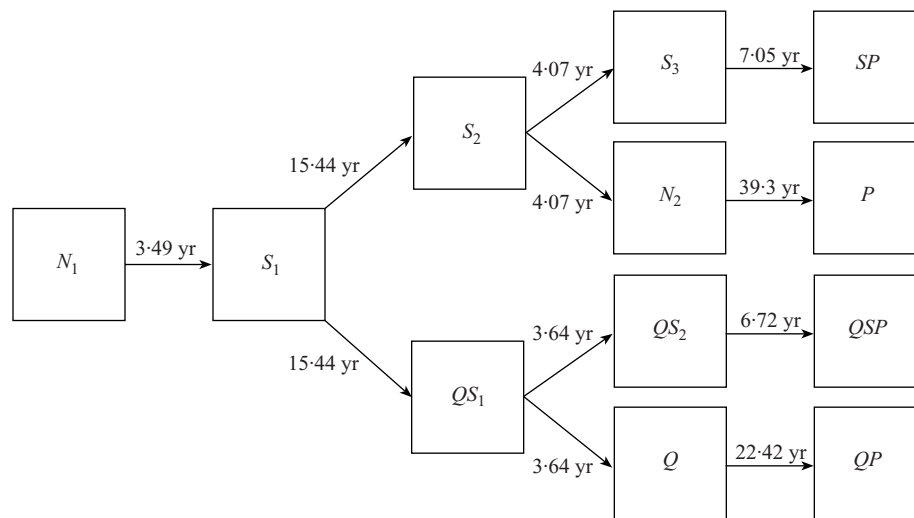

Process	Specification in Figure	Estimated mean time for process (years)	Aggregate mean age (years) to achieve state
Initial seroconversion	$N_1 \longrightarrow S_1$	3.49	3.49
Becoming overweight	$N_1 \longrightarrow QS_1$	15.44	18.93
Seropositivity persists	$QS_1 \longrightarrow QS_1$	3.64	22.57
Proteinuria onset	$QS_1 \longrightarrow QSP$	6.72	29.29
Seropositivity lost	$QS_1 \longrightarrow Q$	3.64	22.57
Proteinuria onset	$Q \longrightarrow QP$	22.42	44.99
Not overweight	$S_1 \longrightarrow S_2$	15.44	18.93
Seropositivity persists	$S_2 \longrightarrow S_3$	4.07	23.00
Proteinuria onset	$S_3 \longrightarrow SP$	7.05	30.05
Seropositivity lost	$S_2 \longrightarrow N_2$	4.07	23.00
Proteinuria onset	$N_2 \longrightarrow P$	39.30	62.30

Fig. 3. Model for development of proteinuria (P) according to M protein antibody status (S) and overweight (Q) status (Quetelet Index $> 25 \text{ kg m}^{-2}$).

munities in Northern Australia. The results show, for the first time, an association between an individual marker of GAS infection (M protein antibody), and the risk of proteinuria in the same individuals (Table 1, Figs 1, 2). To test the possibility that this association may reflect a role for GAS infection(s) in causing proteinuria in Aboriginal adults, we developed models [29] for the possible time sequences for M antibody acquisition and loss and for onset of proteinuria (Fig. 2). The parameter estimates are plausible: the estimated rate of acquisition of M antibodies (some 30% per year for those not yet seroconverted), is consistent

with the observed high rates of childhood streptococcal infection in the community [10]. The estimated rate of loss of M antibodies of 2.5% per year for those still seropositive is consistent with the long-lasting nature of such antibodies [20].

A major conclusion was that the rate of onset of proteinuria when M antibodies persisted (7.8% per year) was significantly greater than the rate (2.7% per year) after reversion to seronegative status, suggesting that the mechanisms leading to proteinuria in adult life are correlated with the persistence of M protein antibodies. A simple interpretation would be that M

protein antibodies persist if GAS (skin) infections are recurrent. Thus, persistent antibodies could mark an increase in risk of proteinuria by mechanisms that do not necessarily involve M protein antibody. This view is consistent with ancillary evidence (Hoy and colleagues, unpublished) showing that proteinuria rates are higher in adults with active skin sores. Another possibility is that the long-term persistence of M protein antibodies reflects an autoimmune response based on cross-reactions between M protein epitopes and autoantigens [32]. Such a delayed autoimmune response could be involved more directly in the pathogenesis of proteinuria following repeated infections.

High rates of proteinuria and ESRF in this population are already known to be familial, with risk factors that include hypertension, non-insulin dependent diabetes mellitus, and overweight [14]. This study identified GAS infection as an additional factor contributing to high rates of proteinuria and ESRF. The model exploring the relationship of seropositivity and overweight to proteinuria (Fig. 3) suggested that overweight did not prolong seropositivity, and accelerated proteinuria only in seronegative subjects.

The clear association of proteinuria with evidence of prior GAS infection in this study is at variance with studies suggesting that APSGN in children is rarely followed by ESRF [4, 5]. However, in Australian Aboriginal communities, where streptococcal skin sores in children have point prevalences of 14% [10] to 60% [13], it is plausible that proteinuria and ESRF are more likely to be due to prior streptococcal infection than would be the case in an affluent population where streptococcal infections and renal disease are much less frequent. The clinical implications from this study are explicit – community education and service delivery aimed at treatment and prevention of persistent or recurrent streptococcal infection will improve the long-term health outcomes for populations with high rates of ESRF.

ACKNOWLEDGEMENTS

We thank Ms Jeni Wie, Ms Betty Criag and Ms Jenny Carter for assistance; Dr Diana Martin for provision of reference strains of *Streptococcus pyogenes*; Ms Jenny Powers and Mr Chris Lai for statistical and computer assistance; Drs Jonathan Carapetis, Tarun Weeramanthri, Bart Currie and Kevin Urdahl for critical comments and suggestions; Mrs Debra Davis

for producing the manuscript. This study was funded by the National Health and Medical Research Council of Australia.

STATISTICAL APPENDIX

Rationale for use of compartmental (or transition-state) models in epidemiology

Compartmental models have been used in areas such as engineering, physics, ecology and in communicable disease epidemiology, but have not been widely adopted in studies of chronic disease. Such models provide a framework to draw inferences from time- (or age-) related variation. This contrasts with most conventional (descriptive) approaches to epidemiological data, where age- (or time-) related variation is often regarded as a ‘nuisance’ to be eliminated, rather than being used for inference.

Such compartmental models seek to model time-dependent transitions between states in a way that allows hypotheses about causal processes to be tested. Furthermore, more informative inferences can emerge with fewer parameters (i.e. simpler models) than with conventional epidemiological analyses.

Model specification and assumptions

In the simplest case there would be two states of a single binary attribute (e.g. presence or absence of proteinuria). The model summarized in Figure 2 is more complex, with two binary attributes: seropositivity (antibodies present or absent) and proteinuria (present or absent).

In a specific application, the assumptions and allowable transitions are based on the biology, and possibly on the results of earlier model fitting. For example the model in Figure 2 does not allow for proteinuria to precede seroconversion, because an earlier model showed that this sequence of events was much less consistent with the data (i.e. it had a lower likelihood).

Specific assumptions for model in Figure 2

1. All individuals start as normal (N_1) from birth.
2. The seropositive state can be temporary (S_1) or become permanent (S_2).
3. A state of proteinuria (P or PS) can follow a seronegative state (N_2) or a seropositive state (S_2).
4. The state of proteinuria (P or PS) is irreversible.

- The transition processes are linear in time, with rate constants K_1 – K_5 .

Specific assumptions for model in Figure 3

- All individuals starts as normal (N_1) from birth.
- The seropositive state (S_1) can become associated with obesity (QS_1) or not (S_2), persist (S_3) or become seronegative (N_2).
- Obese seropositive subjects (QS_1) can become seronegative (Q) or remain persistantly seropositive (QS_2).
- Proteinuria can develop at different rates to give states SP , P , QSP and QP respectively.

REFERENCES

- Wannamaker LW. Differences between streptococcal infection of the throat and skin (Part I). *Lancet* 1970; **282**: 23–31.
- Higgins PM. Acute poststreptococcal glomerulonephritis in general practice: the contribution of infection to its onset and courses. *Epidemiol Infect* 1996; **116**: 193–201.
- D'Espaignet ET, Ommeren MV, Taylor F, Briscoe N, Pentony P. Trends in Australian Mortality (1921–88). Canberra: Australian Institute of Health Mortality Series No. 1. AGPS. 1991.
- Perlman LV, Herdman RC, Kleinman H, Vernier RL. Poststreptococcal glomerulonephritis – a ten year follow up of an epidemic. *JAMA* 1965; **194**: 175–82.
- Potter EV, Lipschultz SA, Abidh S, Poon-King T, Earle DP. Twelve to seventeen year follow-up of patients with poststreptococcal acute glomerulonephritis in Trinidad. *N Engl J Med* 1982; **307**: 725–9.
- Schacht RG, Gallo GR, Gluck MC, Iqbal MS, Baldwin DS. Irreversible disease following acute poststreptococcal glomerulonephritis in children. *J Chron Dis* 1979; **32**: 515–24.
- Baldwin DS. Poststreptococcal glomerulonephritis – a progressive disease? *Am J Med* 1977; **62**: 1–11.
- Buzio C, Allegri L, Mutti A, Perazzoli F, Bergamaschi E. Significance of albuminuria in the follow up of acute poststreptococcal glomerulonephritis. *Clin Nephrol* 1994; **41**: 259–64.
- Munoz E, Powers JR, Nienhuys TG, Mathews JD. Social and environmental factors in 10 Aboriginal communities in the Northern Territory: relationship to hospital admissions of children. *Med J Aust* 1992; **156**: 529–33.
- Van Buynder P, Gaggin JA, Martin D, Pugsley D, Mathews JD. Streptococcal infection and renal disease markers in Australian Aboriginal children. *Med J Aust* 1992; **156**: 537–40.
- Nimmo GR, Tinniswood RD, Nuttall N, Baker GM, McDonald B. Group A streptococcal infection in an Aboriginal community. *Med J Aust* 1992; **157**: 521–2.
- Carapetis J, Gardiner D, Currie B, Mathews JD. Multiple strains of *Streptococcus pyogenes* in skin sores of Aboriginal Australians. *J Clin Microbiol* 1995; **33**: 1471–2.
- Gardiner DL, Sriprakash KS. Molecular epidemiology of impetiginous group A streptococcal infections in Aboriginal communities of northern Australia. *J Clin Microbiol* 1996; **34**: 1448–52.
- Van Buynder PG, Gaggin JA, Mathews HD. Renal disease patterns in Aboriginal Australians: a family-based study in a high incidence community. *Med J Aust* 1993; **159**: 82–7.
- Hoy W, Pugsley D, Hayhurst B, Mathews JD. Treatment of end stage renal disease in the Top End of the Northern Territory 1978–1993. *Nephrology* 1995; **1**: 307–13.
- Gogna NK, Nossar V, Walker AC. Epidemic of acute poststreptococcal glomerulonephritis in Aboriginal communities. *Med J Aust* 1983; **1**: 64–6.
- Carapetis J. An outbreak of acute post-streptococcal glomerulonephritis in an Aboriginal community. *Commun Dis Intell* 1995; **19**: 140–2.
- Rothbard S. Bacteriostatic effect of human sera on group A streptococci. I. Type-specific antibodies in sera of patients convalescing from group A streptococcal pharyngitis. *J Exp Med* 1945; **82**: 93–105.
- Denney FW, Perry WD, Wannamaker LW. Type-specific streptococcal antibody. *J Clin Invest* 1957; **36**: 1092–100.
- Lancefield RC. Persistence of type specific antibodies in man following infection with group A streptococci. *J Exp Med* 1959; **110**: 272–92.
- Nishimura T, Yamada A. Streptococcal type-specific antibody in patients with glomerulonephritis (2): correlation to their histological type. *Jap J Nephrol* 1990; **32**: 855–62.
- Hoy WE, Mathews JD, McCreddie DA, et al. The multidimensional nature of renal disease in Australian Aborigines: findings in a high risk community. *Kidney Int* 1998; **54**: 1296–304.
- Consensus Statement. Preventing the kidney disease of diabetes mellitus. *Am J Kidney Dis* 1989; **13**: 2–6.
- Nathan DM, Rosenbaum C, Protasowicki VD. Single void urine samples can be used to estimate quantitative microalbuminuria. *Diabetes Care* 1987; **10**: 414–8.
- Bradford MM. A rapid and sensitive method for the quantitation of microgram quantities of protein utilizing the principle of protein-dye binding. *Anal Biochem* 1976; **72**: 248–54.
- Rotta J, Krause RC, Lancefield RC, Everly W, Lackland H. New approaches for the laboratory recognition of M types of group A streptococci. *J Exp Med* 1971; **134**: 1298–315.
- Xu Q, Willeit J, Marosi M, et al. Association of serum antibodies to heat shock protein 65 with carotid atherosclerosis. *Lancet* 1993; **341**: 255–9.
- The GLIM System, Release 4.0 (computer program). Oxford Numerical Algorithms Group, 1993.
- Leach AJ, Boswell JB, Asche LA, Nienhuys TG, Mathews JD. Bacterial colonisation of the nasopharynx

- predicts very early onset and persistence of otitis media in Australian Aboriginal infants. *Paediatr Infect Dis J* 1994; **13**: 983–9.
30. Chugh KS, Sakhuja V, Glomerular disease in the tropics. In: Cameron S, Davison AM, Grünfeld J-P, Kerr D, Ritz E, eds. *Oxford textbook of clinical nephrology*, vol I. Oxford: Oxford University Press, 1992: 486–502.
 31. Van Buynder PG, Mathews JD, Pugsley DJ. Hepatitis surface antigen is not associated with chronic renal disease in Aboriginal Australians. *Med J Aust* 1991; **154**: 366.
 32. Kraus W, Dale JB, Beachey EH. Identification of an epitope of type 1 M protein that is shared with a 43-kDa protein of human myocardium and renal glomeruli. *J Immunol* 1990; **145**: 4089–93.