

## What has engineering design to say about healthcare improvement?

P. John Clarkson

Department of Engineering, University of Cambridge, Cambridge CB2 1PZ, UK

### Abstract

This paper builds on the author's keynote address to the Design Society's 21st International Conference on Engineering Design in 2017 and in doing so provides a personal perspective to the question of the title. It begins by describing the engineering experience of the author which led to an understanding of the importance of taking a systems approach to the development of engineering products and services. This is followed by reflections on the development of a research portfolio focused on the design of complex engineering systems, inclusive design and healthcare improvement. The paper then reports on the recent work of engineers, clinicians and healthcare leaders, who came together under the guidance of the author, to explore how an engineering systems approach could be described that might simultaneously meet the needs of patients, carers and healthcare staff. It discusses the challenges associated with the translation of this narrative description of a systems approach (*What?*) into a practical implementation guide or toolkit (*How?*), supported by evidence of its effective use in health and care improvement practice. Finally, the paper reflects on the lessons to be learned from this process and their possible repercussions for design research and the practice of design.

**Key words:** healthcare, systems, design, risk and people

### 1. Introduction

What has engineering design to say about healthcare improvement? This question is inspired not only by the current challenges facing the delivery of health and care, but also the author's experience of engineering and healthcare drawn from more than three decades of experience working in practice and research. This paper broadly follows the narrative of the keynote address given to the 21st International Conference on Engineering Design at the University of British Columbia, Vancouver, Canada in August 2017, describing the author's formative experiences and their influence on the development of a systems approach to *Engineer Better Care* (Clarkson *et al.* 2017). Much of the rationalisation provided is necessarily 'after the event', born of time to reflect on matters that have only in the past few years begun to make sense, particularly in the context of having to explain to health and care providers, and patients, what engineers actually do.

The narrative that follows tracks the author's career from PhD to practice and from practice to research, focusing on the lessons learned that ultimately contributed to an *understanding* of the importance of a systems approach and its description in a form of value to both engineers and non-engineers. Yet the journey has just begun, as the translation of the definition of a systems approach

Received 10 November 2017

Revised 25 July 2018

Accepted 31 July 2018

#### Corresponding author

P. John Clarkson  
pjc10@eng.cam.ac.uk

Published by Cambridge  
University Press  
© The Author(s) 2018  
Distributed as Open Access under  
a CC-BY 4.0 license  
(<http://creativecommons.org/licenses/by/4.0/>)

*Des. Sci.*, vol. 4, e17  
[journals.cambridge.org/dsj](http://journals.cambridge.org/dsj)  
DOI: 10.1017/dsj.2018.13

the **Design Society**  
a worldwide community

 **CAMBRIDGE**  
UNIVERSITY PRESS

torque 
$$T = \frac{npk_c L_1 V_0}{2r\sqrt{r^2 + u^2 L_0^2}} \left( V_1 \cos(\varphi - \delta) - \frac{u L_1 V_0}{\sqrt{r^2 + u^2 L_0^2}} \right)$$

motion 
$$J\ddot{\theta} + (B + pT'_\delta)\dot{\theta} + pT'_\delta\theta = -T_l$$

stable if 
$$B + pT'_\delta > 0$$

where 
$$T'_\delta = \frac{npk_c L_1^2}{4r(r^2 + u^2 L_0^2)} \left( V_1^2 \cos^2(\varphi - \delta) - \frac{V_0 V_1 u L_1}{\sqrt{r^2 + u^2 L_0^2}} \cos(\varphi - \delta) + 2V_0^2 \frac{r^2 - u^2 L_0^2}{r^2 + u^2 L_0^2} \right)$$

Figure 1. Equations of motion for a variable-reluctance stepping motor.

(*What?*) into a practical implementation guide for health and care improvement (*How?*), and real change in practice, remains rather more demanding and illusive.

## 2. The early years

The story begins in the early eighties with the author working for the English Electric Valve Company (now known as e2v) and studying engineering at the University of Cambridge. Work on leddicons, klystrons, travelling-wave tubes large valves and bespoke LCD displays led to an early fascination for *sculptural* electronic systems, where performance was determined by the particular combination of mechanical, electrical and control attributes of a *product* that then served as a *component* in a larger broadcasting or imaging *system*.

A PhD followed on the modelling and control of stepping motor systems, where such motors are essentially digital devices – you tell them to *step* once and they rotate one step, you tell them to *step* repeatedly and they rotate continuously. Stepping motors are known to exhibit low-speed resonances, where the *step* rate excites mechanical resonances, and high-speed resonances where motion is not sustainable (Clarkson & Acarnley 1988). Further investigation (Figure 1) shows that the motor, with its associated drive, converts electrical power into torque ( $T$ ) which is dependent on the position of the motor when the next *step* is requested (*switching* angle,  $\delta$ ), and that the resulting physical motion is damped ( $B + pT'_\delta$ ) at a rate dependent on the speed and switching angle (Clarkson & Acarnley 1989).

Surprisingly, this electrical damping ( $pT'_\delta$ ) may be negative, leading to instability when its magnitude exceeds the mechanical damping ( $B$ ) present in the system. Typical graphs of the torque ( $T$ ) and electrical damping ( $pT'_\delta$ ) highlight this potential for instability when drawn with the operating curve (load-line) for a motor and drive in a given mechanical system (Figure 2). The addition of software to control the switching angle ( $\delta$ ) and the use of closed-loop control (where the *step* command is only generated when the previous step is complete) can stabilise the motor system, combining the benefits of stability associated with closed-loop control and the speed-following capability of open-loop control.

In retrospect, this was an early introduction to the fascinating world of systems where artefacts of the emergent performance (in this case, instability) could only be avoided with deep knowledge of the system, its components and their

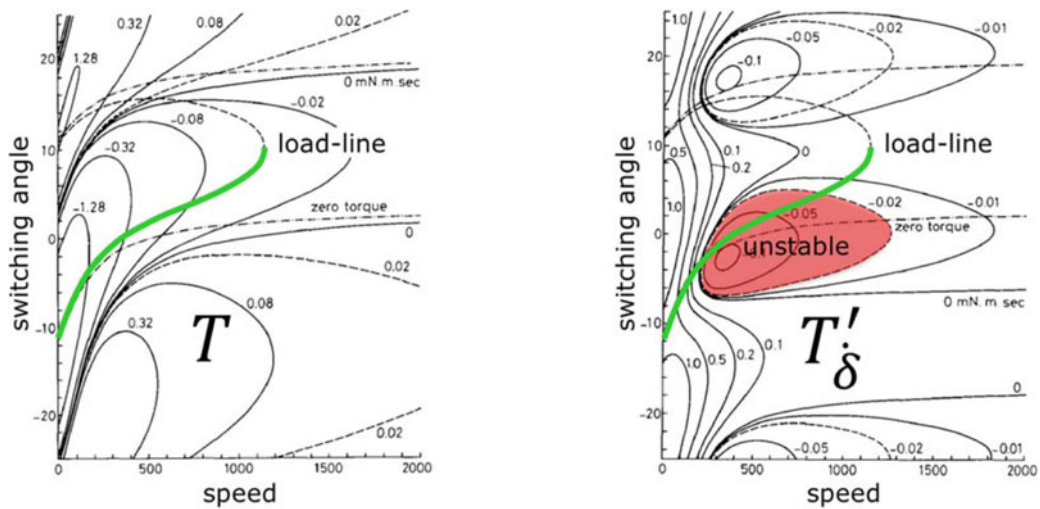

**Figure 2.** Plots of torque ( $T$ ) and electrical damping ( $pT'_\delta$ ) for a variable-reluctance stepping motor, with the load-line shown in bold (green) and the area of instability shaded (red).

integrated performance. Thirty years later a close relative of the stepping motor, the brushless DC motor, is now used as a key component in electric vehicle transmission systems.

### 3. The middle years

Academic study completed, the author joined the Advanced Process Group, at PA Consulting Group's Technology Division (PA), as a motion-control specialist. A variety of fascinating projects followed, from chocolate manufacturing to pharmaceutical test equipment, from inhaler development to the design of widget beer, and from automated inspection systems to firefighting training. The examples that follow capture the flavour of these projects and some of the lessons learned from their timely delivery by the author, working with an exceptional group of engineering colleagues for some inspired clients.

#### 3.1. Firefighting training

Firefighting training for all UK Navy personnel was enhanced following the sinking of HMS Sheffield in 1982. New computer-controlled systems were explored as a possible replacement for earlier passive units which relied on diesel fuel and wood fires, set in confined spaces, to train individuals and teams in the art of firefighting. The diesel fires were inconsistent and training sessions hard to repeat, while new butane burners brought potential rigour and controllability to the process. PA was contracted to develop a prototype training system, a single room within which fire trials could be enacted and new equipment evaluated, as a means to identify the requirements for the next generation of national training facilities. The author was responsible for developing the automatic control systems for this prototype, known as the Fire-Fighting Training Unit (FFTU).

The new FFTU comprised burner control *systems*, smoke generators, hot-air generators, sensors for water and foam, and control and monitoring *systems*.

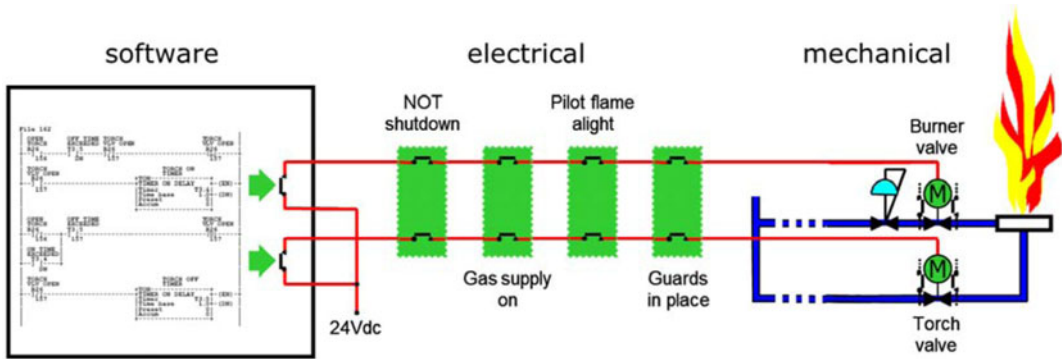

**Figure 3.** Safe control of the flame height required the coordinated operation of valves (mechanical), interlocks (electrical) and control algorithms (software).

The sensor *design* was unique to the fire-training system, allowing operation in particularly harsh conditions, and the *design* of the control systems required multiple *risk* analyses to be performed to ensure the safety of people and equipment in use. On this matter, two issues dominated the development of the automated FFTU: (1) the requirement that no more than one officer should be killed during the ten-year life of the prototype; and (2) the understanding that the author would be required to test the automated FFTU before the training officers would take charge of the unit. From an early stage it became clear that the FFTU was a complicated system of *systems*, with layers of local and global control, safety-critical electrical interlocks and high-reliability electro-mechanical sensors and actuators. All of these were required to work seamlessly together to ensure the safety of personnel and deliver a realistic training experience (Figure 3).

The software was developed, using structured systems analysis and *design* methods, to ensure high levels of performance integrity and a clear mapping between the software functional diagrams and the resultant code (Figure 4). This approach naturally took a *systems* approach to identify the appropriate functional and solution architectures for the FFTU, using a terminology that mapped directly from the physical to the software domain. Four months of diagramming led to one month of coding and near fault-free code.

*Risk* assessment was undertaken on the proposed system to ensure sufficient levels of safety and reliability, taking account of the variety of ways in which personnel might be injured. A number of elements were subsequently re-specified to introduce serial redundancy as a means to reduce potential failure rates and a guard rail was added to remove the risk of anyone falling on the most severe fires (Figure 5). Falling down the stairs on entering the unit was deemed acceptable.

Ultimately, the system was all about *people*. The FFTU had to be sufficiently realistic to convince the fire-training officers that it would provide a suitable training environment for all naval shipboard personnel. It also had to be safe. Tea breaks during commissioning of the FFTU saw the author counting the number of officers present, where ten was a particularly stark reminder of the safety requirement for the unit. The system was ultimately delivered on time with only four minor errors found in the software during commissioning. Ten years on, with insights gained from using the prototype FFTU and no fatalities, the Navy

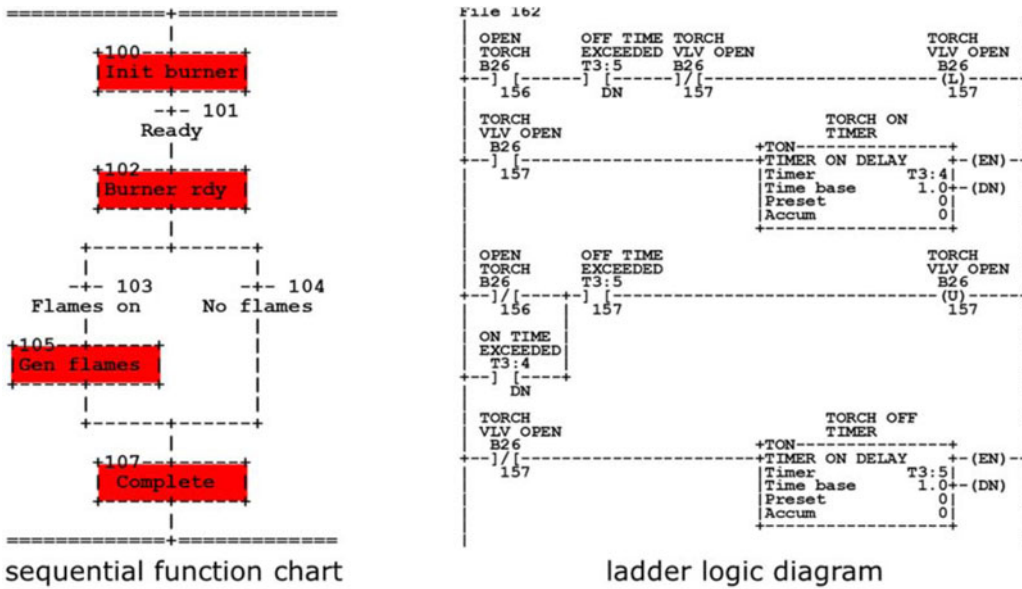

Figure 4. The firefighting control software combines sequential function charts (coordination logic) and ladder logic diagrams (detailed functions) with a clear data structure to deliver high-integrity code.

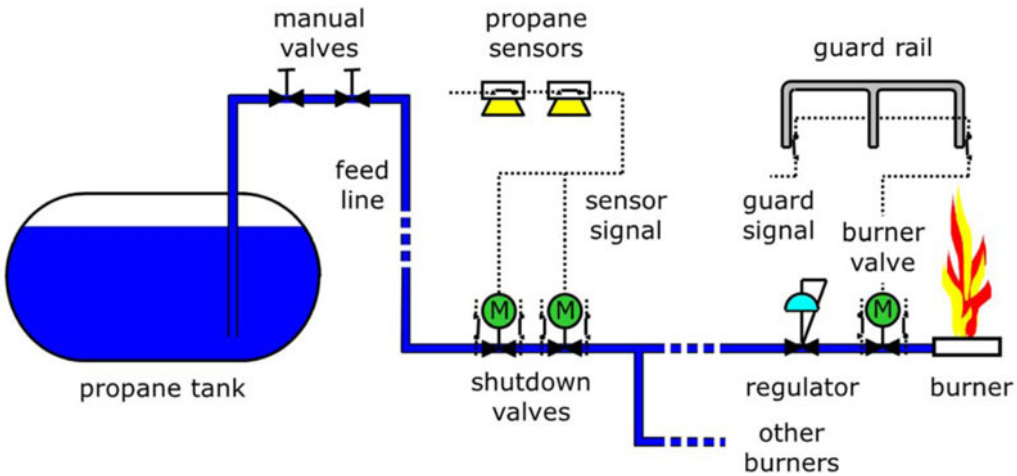

Figure 5. The firefighting control hardware combines manual, shutdown and analogue (burner) valves with safety sensors (propane) and physical interlocks (guards) to ensure adequate levels of safety.

purchased new fire-training facilities across the UK with a revised safety limit of no more than one trainee to be killed every 100 years across all units.

### 3.2. Widget beer

Nitrogenated beer, such as stouts and porters, had long been the preserve of public houses (establishments licensed to sell alcoholic drinks) in the UK where they were supplied in casks and sold on tap. They have a characteristic fluffy white

head on top of the beer and a smooth, creamy texture (Evans & Sheehan 2002). However, *people* were increasingly drinking beer at home, but wanted to retain the cask taste. Subsequent efforts to deliver nitrogenated beer in a can began with Guinness in the late 1960s, resulting in the introduction of the first *widgit* beer in 1989. The development of a new widgit for John Smiths in the early 1990s provided a significant challenge for PA. How to deliver a new product to market in under ten months without the competition and the client's employees knowing what was going on?

This project was all about *design*: a new widgit (device) in the can to enable the release of nitrogen bubbles into the beer when it was opened, which would not contravene existing patents and had to produce a winning consumer experience. It was about *systems*: with a need to develop the widgit in parallel with the means to insert it in the can and the equipment to process it prior to filling the can with beer. It was also about *risk*: with a need not only to keep operators safe when infusing the widgit with nitrogen, but also to maximise commercial success by surprising the competition with the introduction of the new product.

The key components of the system are shown in Figure 6. The early conceptual design of the widgit, with its three flexible *arms* linked to a flexible ring, was simple genius. It allowed the independent development of (1) the details of the core of the widgit required to deliver a good beer, (2) the means to insert the widgit in the can and deliver it to the brewery, and (3) the bespoke technology required to fill the widgit with nitrogen prior to the addition of beer. Crucially, the way in which the widgit delivered nitrogen into the beer avoided infringement of all existing patents. The contracting of the haulier, who took empty cans to the brewery and full cans to the distributors, to insert the widgit in the empty cans further simplified the delivery system.

Due to the extraordinary efforts of the team at PA, in collaboration with the client and local hauliers, the product was launched in time for the Christmas market, accompanied by an award-winning advertising campaign with comedian Jack Dee that transformed the business with like-for-like sales increasing by 65%.

### 3.3. Lessons learned

A common theme emerged in much of the author's work at PA, the necessary presence of different perspectives when delivering complex products, namely *systems*, *design*, *risk* and *people*. Whilst not fully appreciated at the time, an understanding of these perspectives and the skill to reflect on them alongside the application of sound, risk-based project management would often make the difference between success and failure in the delivery of happy clients.

Design tools were borrowed from all areas of engineering to facilitate the development of good practice and deliver excellence. In particular, inspiration was drawn from software engineering to identify diagramming approaches suitable not only for software design, but also for the coordination of mechanical, electrical and software development, i.e. systems design. Risk assessment methods were also drawn from other industries and adapted to enable a holistic approach to systems safety assessment.



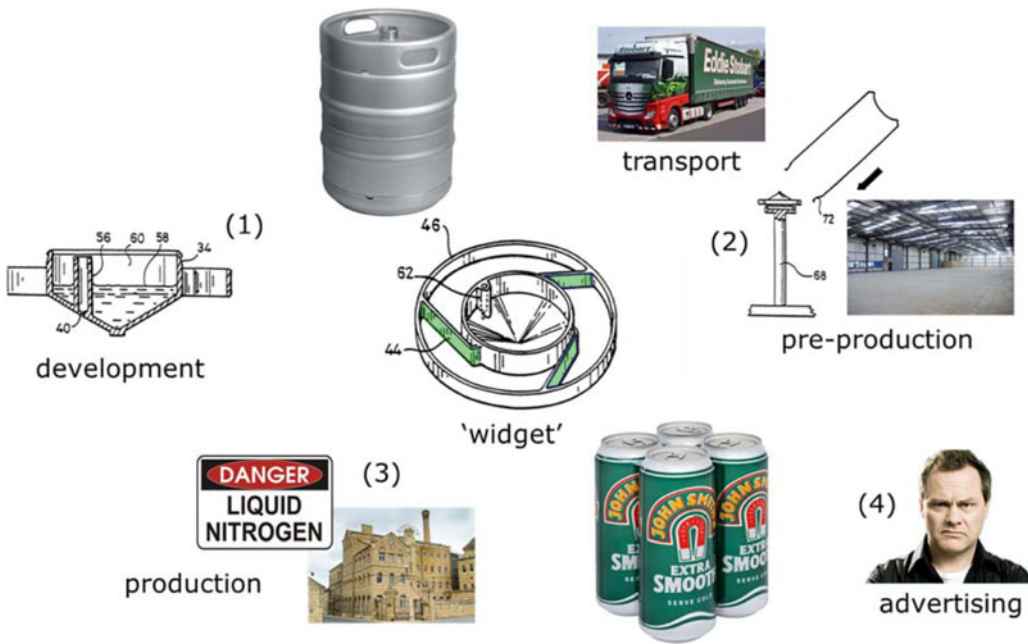

**Figure 6.** The ultimate success of John Smith’s *draft* beer in a can relied upon the coordinated and independent development of a *widget*, widget insertion facilities (pre-production), safe filling of the cans (production), transport and an advertising campaign by Jack Dee.

#### 4. The latter years

On returning to the University of Cambridge as a Lecturer in Engineering Design, the author engaged in a broad range of research activities focused on improving the design process. Early opportunities to work with Westland Helicopters (now part of LEONARDO) led to research on the mapping and simulation of *design* processes (Clarkson & Hamilton 2000) and the development of approaches to predict the propagation of change in complex *systems* (Clarkson, Simons & Eckert 2004b). Both approaches were subsequently translated into practical tools as part of the Cambridge Advanced Modeller (CAM), a research toolkit designed to assist in the modelling and simulation of complex processes and systems (Wynn, Grebici & Clarkson 2011; Hamraz, Caldwell & Clarkson 2013).

At the same time, more than a decade of collaboration with the Royal College of Art on Inclusive Design (Clarkson & Coleman 2015) led to the development of an online Inclusive Design Toolkit to assist designers in the *design* of products and services for older and less able people (Waller *et al.* 2015). In addition, research into medical devices and healthcare *systems*, led to the publication of a report for the UK Chief Medical Officer on ‘Design for Patient Safety: a system-wide design-led approach to tackling patient safety in the NHS’ (Department of Health & Design Council 2003; Clarkson *et al.* 2004b) and the development of an online System Safety Assessment Toolkit (Ward, Buckle & Clarkson 2010) to assist healthcare professionals in the evaluation of *risk*. Research continues to merge these toolkits and deliver a systems-based Healthcare Design Toolkit.

These seemingly divergent areas of research mask a continuing fascination with complex systems, whether they be engineering or people based. Research

questions regarding the nature of design and design processes, and the means to capture or describe them, sit alongside questions regarding the nature of systems, their architecture, development, performance and evaluation. Fundamentally, the common interest here may be summarised as *How can we make it better?* and *What could possibly go wrong?* – half a lifetime of engineering research, training and practice captured in two simple questions!

In time, these questions accumulated a particular significance in health and care improvement, in large part due to the increasing research conducted by the author in healthcare design and a realisation of the real potential for embedding engineering thinking in this area. The report for the UK Department of Health (Department of Health & Design Council 2003) had highlighted worldwide levels of medical error that were potentially avoidable and called for the use of a *systems approach* to transform health and care. However, there had been a distinct lack of a clear definition of what this might mean in practice in a health and care context.

The remainder of this paper describes the author's engagement with the Royal Academy of Engineering in the UK to develop such a definition. It documents the process leading to the publication of *Engineering Better Care* (Clarkson *et al.* 2017), a description of a systems approach to health and care design and continuous improvement and presents the key message contained within the report, namely the importance of *systems, design, risk* and *people* perspectives when delivering complex products and services. While focus is derived from the author's previous research and practice, the detail in the sections that follow was influenced by all those involved in the co-creation of the report.

### 5. A conversation between engineering and healthcare

The challenges facing the health and social care systems are considerable – with competing pressures from an ageing population, increasing numbers of patients with multiple morbidities, new technologies, and the need for increasing efficiencies. The complexity of such systems mean that efforts to improve them often achieve only limited benefits and can have unforeseen consequences. Over the past two decades, there have been many calls to implement a more holistic systems approach to transform health and care, however, there has been no clear definition of what this might mean in practice.

Yet engineers routinely use a systems approach to address challenging problems in complex projects. They consider the layout of the system, defining all the elements and interconnections, to ensure that the whole system performs as required. For example, in the delivery of the London 2012 Olympic and Paralympic Games, physical infrastructure and practical organisation were brought together, with innovative engineering, modelling and simulation of people flows, early testing of venues, and extensive risk management (Armitt 2011). There is, therefore, real value in exploring the potential of applying a systems approach to the delivery of health and care.

In response to this challenge, the Royal Academy of Engineering (RAEng), in collaboration with the Royal College of Physicians (RCP) and the Academy of Medical Sciences (AMS), established a cross-disciplinary Working Group, chaired by the author, 'to work with the health and care professions to explore how engineers can add to current understanding and practice of systems engineering in quality improvement and healthcare design.' The background to this work and the approach taken are described in the following sections.



## 5.1. Health and care systems

The UK National Health Service (NHS), like many around the world, is under pressure (Berwick 2013; Vincent & Amalberti 2016). Demands placed on it are changing as a result of an ageing population, obesity, dementia and a growing number of people living with multiple health needs. In addition, opportunities to tackle these complex issues are being hampered by ongoing economic pressures. The UK system, amongst many others, needs to change in response to these challenges if it is to deliver a service that continues to be fit for the future (Department of Health & Design Council 2003).

The NHS is one of the most complex systems in the world and its Five Year Forward View (NHS England 2014, 2015a) sets out how it needs (1) to adapt to changing demands and expectations, delivering greater efficiency with growing resource challenges and a limited central budget, (2) to define a different relationship between the public and the health and care system, (3) to better understand and manage risk, learning from past failures and crucially successes, and (4) to adopt a systems approach to designing and delivering high-quality services. In this context, and in contrast to more conventional views, quality is defined as the simultaneous achievement of clinical and cost effectiveness, a satisfactory patient experience and acceptable levels of patient safety.

Improvement in health and care has become an established discipline, typically exemplified by the use of the Institute for Healthcare Improvement's (IHI) Model for Improvement (Langley *et al.* 2009), the adoption of lean thinking techniques, the adaptation of risk registers, checklists and human factors approaches to improve patient safety, and the use of comparative data to monitor performance. What has also evolved is a blame culture that inhibits organisational learning, even though it is increasingly accepted that 'human beings make mistakes because the systems, tasks and processes they work in are poorly designed' (Leape 1997) and that 'if healthcare is to significantly reduce patient harm, a holistic perspective is necessary to capture the requirements and needs related to the culture, workflow, and technology associated with caring for patients' (Pronovost *et al.* 2015).

The adoption of a systems approach to improvement, although advocated in an increasing number of healthcare reports (Koln, Corrigan & Donaldson 2000; Bristol Royal Infirmary 2001; Department of Health & Design Council 2003; Reid *et al.* 2005; Berwick 2013; Ham, Berwick & Dixon 2016; Hussain & Dornhurst 2016), is relatively rare and exacerbated by the dearth of descriptions *what* a systems approach is and *how* it might deliver better care.

## 5.2. An engineering systems view

The engineered world is full of systems. From the simple water heater to the fully integrated international airport, from ancient irrigation systems to modern communication networks, all systems share one key feature: their elements together produce results not obtainable by the same elements alone. These elements, or parts, can include people, processes, information, organisations and services, as well as software, hardware and other systems.

Systems have the ability to encourage good behaviour or mistakes, and the difference is the result of the quality of their design, delivery and use. 'Systems that work do not just happen – they have to be planned, designed and built' (Elliott & Deasley 2007). Critically, the layout of the system, defining all the elements

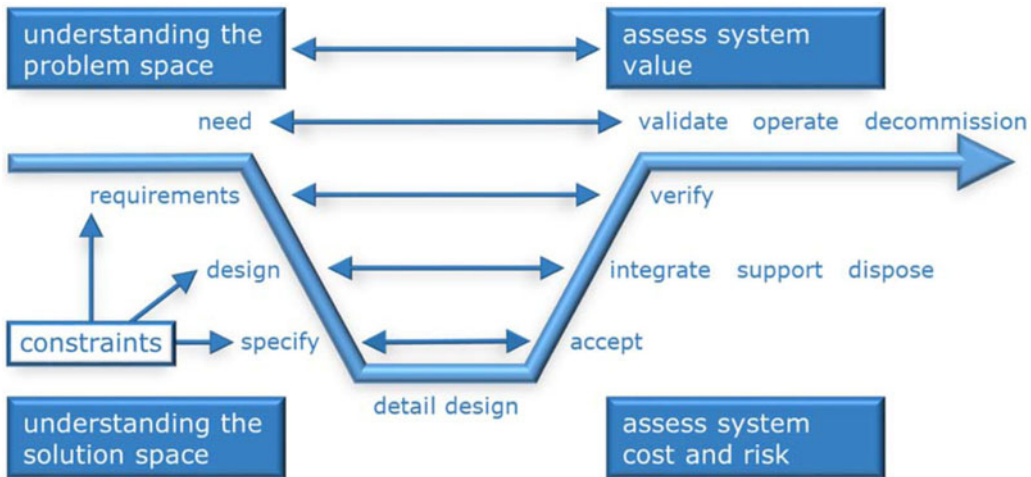

**Figure 7.** The V-model (INCOSE 2009).

and their interconnections, needs to be carefully considered to ensure that each element on its own and in combination with others performs as required.

The engineering view of a systems approach is typically described in the context of Systems Engineering, which integrates all the necessary disciplines and speciality groups into a team responsible for using a structured development process that proceeds from needs to requirements to concepts and from design to production to operation, addressing all the stakeholders' business and technical needs (Cowper *et al.* 2014; NASA 2016; Greene *et al.* 2017).

In addition, the International Council on Systems Engineering (INCOSE) has developed a language of and resources for engineering systems. It describes systems thinking as 'a framework for seeing interrelationships rather than things, for seeing patterns rather than static snapshots – it is a set of general principles spanning fields as diverse as physical and social sciences, engineering and management.' The V-model (INCOSE 2009) illustrates the logical relationships between the different systems engineering activities or processes (Figure 7).

The V-model provides an extraordinary summary of systems engineering, capturing all that is good about it and presenting this in a way that genuinely illustrates many of the key tenets of such an approach. However, to those who are not steeped in the mystery and practice of working with systems, it often seems rather bewildering. Early discussions with the RAEng Working Group reflected on the importance of *people*, *systems*, *design* and *risk* perspectives on a system, and on the realisation that informed focus on these complementary views could deliver many of the benefits of a systems approach (Figure 8):

- (i) *People* – the understanding of interaction among humans and other elements of a system in order to optimise human well-being and overall system performance;
- (ii) *Systems* – the means to address complex and uncertain problems, involving highly interconnected technical and social entities that produce emergent behaviour;



**Figure 8.** A systems approach as a combination of *systems*, *design*, *risk* and *people* perspectives.

- (iii) *Design* – the identification of the right problem to solve, creation of solution options and refinement of the best of these to deliver an appropriate solution to the problem;
- (iv) *Risk* – the management of what can go wrong (and right), based on the identification, assessment and management of hazards and opportunities present within the system.

These perspectives provided the framework for a *briefing document* which was later to be reworked into the *Engineering Better Care* report (Clarkson *et al.* 2017). Their integration into a coherent systems approach was described as a simple sum, i.e. that all the perspectives were necessary and that they should co-exist in an integrated approach where: (1) the *systems*, *design* and *risk* perspectives were interconnected, with any one inevitably leading to the need for the others; and (2) the *people* perspective permeated all the activities associated with the other three.

The impact to the health and care system of adopting such an approach could be immediate and significant, leading directly to benefits in terms of quality, described as including clinical outcomes, experience or safety, and delivery and cost (Clarkson *et al.* 2017).

### 5.3. Co-designing the language of a systems approach

A series of workshops were convened in Autumn 2016, each with a different focus on a systems approach. The first three explored the *systems*, *design* and *risk* perspectives, and the fourth looked to integrate the learning from these. The idea was to generate thought leadership from a group of people who would not normally have met and generate a network of engaged organisations and individuals committed to taking the resulting framework into action. The attendees for the workshops included patient leaders, clinicians, physicians, pharmacists, systems engineers and improvement professionals.

In advance of the workshops participants were sent the *briefing document*, which contained the rationale for the study, an agenda for the day, an outline of a proposed systems approach and a list of existing improvement initiatives and literature. This format was chosen to facilitate greater input from the workshops in the co-design of the final description of the systems approach. In summary, the workshop objectives were to:

- (i) better understand the needs of health and care professionals striving for transformational change;
- (ii) better understand the engineering principles and practices that would add value to current knowledge and practice;
- (iii) co-design a framework for delivering a systems approach with health and care professionals and system engineers.

The participants invited to the workshops were representative of the intended audience for the outcomes and also included active healthcare improvement practitioners and systems engineering experts. A total of 53 different individuals attended with 23 of these attending three or more of the workshops. The workshops were followed by a period of reflection, leading to the publication of a report entitled *Engineering Better Care* (Clarkson *et al.* 2017) in Autumn 2017.

## 6. A systems approach

The sections that follow summarise the progress and findings of the workshops, both in terms of the individual perspectives discussed, and an integrated view of these perspectives in the form of a holistic systems approach.

### 6.1. A systems perspective

A *systems* perspective ensures the design and improvement of safe and efficient systems that satisfy their required purpose in the context of a wider system. In this context, a system is a set of elements: people, processes, infrastructure, information, organisations and services, as well as software, hardware and other systems which, when combined, may have qualities that are not present in any of the elements themselves. A systems perspective takes a holistic approach to understanding this complexity that enables the delivery of intended outcomes based on the way in which a system's constituent parts relate to each other and to the wider system (Elliott & Deasley 2007; INCOSE 2009, 2014; NASA 2016).

The world is made up of a set of highly interconnected technical and social elements which produce emergent behaviour and challenges for communication and control. Some systems are simple, others are chaotic (Kurtz & Snowden 2003; Snowden & Boone 2007). Some are complicated with many elements, but operate in patterned ways, others are complex with features whose interactions are continually changing. It is the co-production of health outcomes with the patient, often across a number of systems rather than with any individual health and care system, that can add significant complexity and uncertainty, leading to behaviours not expected when focus is limited to individual systems. As a result, the solution to a challenge may actually involve changing another system and not the one where the problem or symptom is appearing, relying on collaboration and an integrated holistic view of the systems (Elliott & Deasley 2007).

The *systems* workshop was attended by 22 healthcare specialists, nine engineers, one patient representative and the Academy secretariat. It began with an introduction to the whole programme with time for discussion of the briefing document. The systems perspective was illustrated using the narrative of a patient's journey to a medical consultation, resulting in a prescription for medication, dispensed by a pharmacist and managed at home (Figure 9).

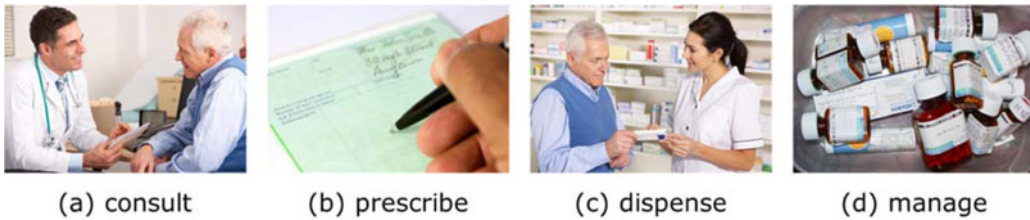

**Figure 9.** The systems perspective illustrated by a typical patient journey: (a) patient attends consultation due to ongoing with pain from arthritis; (b) doctor prescribes daily doses of methotrexate; (c) pharmacist dispenses medication; and (d) patient manages their medications at home.



**Figure 10.** The systems perspective illustrated by the human body as an excellent example of a systems of systems.

Exercises to elaborate on a systems perspective were followed by a *World café* – a series of round table discussions based on known engineering examples, including the firefighting training unit, of the successful application of a systems approach. The workshop closed with discussion on the applicability of a systems perspective to health and care improvement and a review of the insights gained during the day. Subsequent reflection led to the definition of key questions and related topics to describe the essence of the systems perspective (Figure 10):

- (i) *Understand* – Who are the stakeholders?
- (ii) *Organise* – What are the elements?
- (iii) *Integrate* – How does the system perform?

The original description of a systems perspective as *stakeholders*, *disaggregate* and *integrate*, was changed as a result of the workshop and the critical phases were renamed as *understand*, *organise* and *integrate*. Further insights and reading on the systems perspective may be found in Annex 3 of the *Engineering Better Care* report (Clarkson *et al.* 2017).

## 6.2. A design perspective

A *design* perspective ensures that systems are delivered using a range of perspectives, creative approaches and evaluation strategies in order to meet stakeholder needs. It has been argued that many problems addressed by designers are wicked problems (Rittel & Webber 1973), defined as a class of problems that are ill-formulated, where the information is contradictory, where there are many

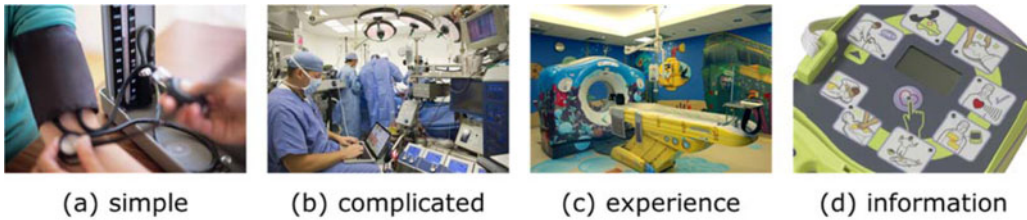

**Figure 11.** The design perspective illustrated by a range of design challenges: (a) a device to measure blood pressure; (b) a piece of equipment in an operating theatre; (c) an underwater adventure for children undergoing a CT scan; and (d) information for the novice user of a public access defibrillator.

stakeholders with conflicting values, and where behaviours within the system are confusing. In response, the Design Council's *double diamond* (Design Council 2007) comprises an initial analytical phase, which determines all of the elements of the problem and specifies the requirements for a successful solution, and a synthesis phase, which generates a range of possible conceptual solutions and an implementation plan.

The design process is typical of those used to address open-ended, wicked problems, where it is not only highly creative, but also very likely to be iterative in order to deal with the intrinsic uncertainty in understanding the real needs and finding an appropriate solution. This is evidenced by the Institute for Health and care Improvement's (IHI) iterative model for improvement (Aim, Feedback, Changes, Plan, Do, Study and Act), often encountered in health and care improvement, where the planning stage is particularly influential in ensuring the delivery of safe systems into practice (Langley *et al.* 2009).

The *design* workshop was attended by 17 healthcare specialists, eight engineers, two patient representatives and the Academy secretariat. It began with an introduction to the whole programme with time for discussion of the briefing document and the first workshop. The design perspective was illustrated by a number of examples of design, ranging from the simple to the complicated and reflecting on the need to design beyond the product to deliver an experience or to deliver clear instructions for use (Figure 11).

Exercises to elaborate on a design perspective, looking at the use of patient personas and scenarios were followed by a *fishbowl* discussion to identify points of particular interest and *light-bulb* moments. The workshop closed with discussion on the applicability of a design perspective to health and care improvement and a review of the insights gained during the day. Subsequent reflection led to the definition of key questions and related topics to describe the essence of the design perspective (Figure 12):

- (i) *Explore* – What are the needs?
- (ii) *Create* – How can the needs be met?
- (iii) *Evaluate* – How well are the needs met?

The original description of a design perspective, based on years of prior research in Inclusive Design and comprising elements labelled *explore*, *create* and *evaluate*, remained unchanged as a result of the workshop. Further insights and reading on the design perspective may be found in Annex 3 of the *Engineering Better Care* report (Clarkson *et al.* 2017).



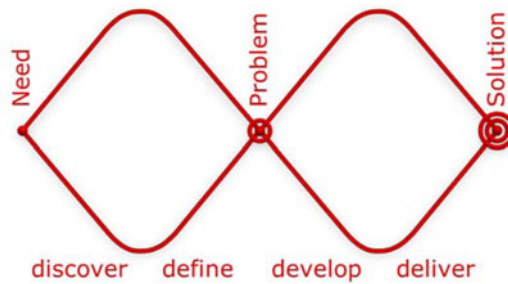

**Figure 12.** The design perspective illustrated by the Design Council's (2007) *double diamond* model of design which emphasises the need for clear problem identification.

### 6.3. A risk perspective

A *risk* perspective ensures that system threats and opportunities are identified and their consequent risks are managed in accordance with stakeholder expectations. Engineering risk and safety management methods, such as Failure Mode and Effects Analysis, Hazards and Operability Analysis and Fault Tree Analysis (British Standards 2009), are used to identify potential threats and opportunities within a system and to manage their likelihood and/or impact on people, property, progress or profit. The role of risk management is to identify, assess and control the level of known risk, accepting the inherent threat or opportunity that may be present within the system, in particular with complex medical interventions and in the distributed system of social care.

Risk can be referenced to a system's ability to deliver high-quality, cost-effective care, where quality is defined as the combination of clinical and cost effectiveness, patient safety and patient experience (Clarkson *et al.* 2004a; Hollnagel, Wears & Braithwaite 2015). Risk management is commonly used as a clinical tool for the prospective analysis of an individual patient's risk, with or without a particular intervention. However, it may also be used to evaluate the risk in sustaining or not achieving the desired outcomes for a population of patients (for example, central venous catheterisation, Horberry *et al.* 2014), the efficiency of a care process or the finances of a care provider. Risk may also be attributed to uncertainty in performance where mitigation will likely focus on the identification of the sources of such variation and their reduction.

The *risk* workshop was attended by 13 healthcare specialists, eight engineers, two patient representatives and the Academy secretariat. It began with an introduction to the whole programme with time for discussion of the briefing document and the first two workshops. The risk perspective was illustrated by descriptions of known areas of clinical risk, the safety issues associated with people-based systems and the human capacity for making mistakes (Figure 13).

Exercises to elaborate on a risk perspective were followed by a discussion to identify current health and care approaches to risk management and an introduction to the use of Failure Mode and Effects Analysis. The workshop closed with discussion on the applicability of a risk perspective to health and care improvement and a review of the insights gained during the day. Subsequent reflection led to the definition of key questions and related topics to describe the essence of the risk perspective (Figure 14):



**Figure 13.** The risk perspective illustrated by a range of challenges: (a) the insertion of a central venous catheter in a busy operating theatre; (b) interaction with complicated equipment; (c) information exchange on a ward; and (d) Hamilton stopping at the wrong pit during the 2013 Malaysian Grand Prix.

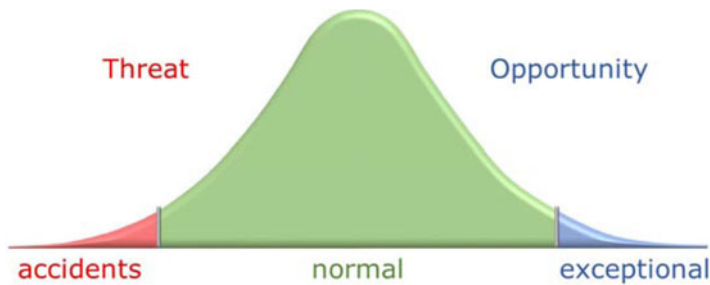

**Figure 14.** The risk perspective illustrated by an outcome distribution curve where the motivation is to move the curve to the right to make the exceptional normal and to eliminate accidents.

- (i) *Examine* – What is going on?
- (ii) *Assess* – What could go wrong?
- (iii) *Improve* – How can we make it better?

The original description of a risk perspective, as *examine*, *assess* and *implement*, was changed as a result of the workshop, renaming *implement* as *improve*. Further insights and reading on the risk perspective may be found in Annex 3 of the *Engineering Better Care* report (Clarkson *et al.* 2017).

#### 6.4. A people perspective

A *people* perspective uses knowledge of stakeholders’ abilities, experience, competence and culture to enable the design of systems that are fit for their intended purpose. The contribution of treatments, equipment, buildings and estates, systems, processes and protocols are undeniably critical to health and care provision; however, it is people who ultimately affect the quality of that delivery. An appropriate awareness of people applies not only to the recipients of care (Hosking *et al.* 2014; Erwin & Krishnan 2016), but also the providers of care (Lucas & Nacer 2015). It is important to acknowledge diversity and that health and care services should be accessible to, and usable by, as many people as reasonably possible, regardless of age (Keates & Clarkson 2003; Hosking, Waller & Clarkson 2010; Waller *et al.* 2015). Equally, it is important to understand that a chief executive can have a significant impact on an organisation through their

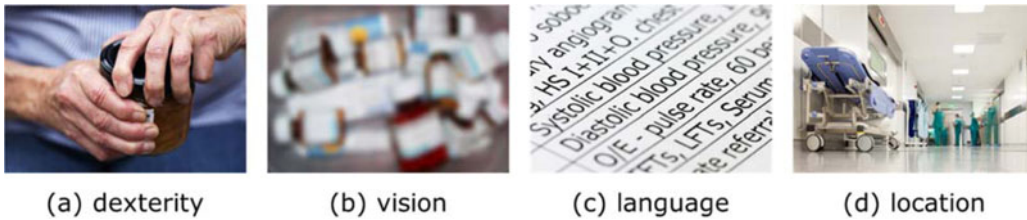

**Figure 15.** The people perspective illustrated by diversity and location: (a) reduced dexterity as a barrier to opening containers; (b) reduced vision as a barrier to identifying medication; (c) language as a barrier to understanding; and (d) local culture and expertise as key factors in implementing change.



**Figure 16.** The people perspective illustrated by the diversity of the patient and carer population.

actions and behaviour, creating a culture that values the importance of the quality of relationships between employees and, most critically, the people in their care.

People are at the heart of an effective systems approach (NHS England 2015b), permeate all stages of the development and delivery of a system, and are central to the effective management of *systems, design and risk*. A *people* perspective serves to involve patients, practitioners and the public to ensure that the systems created are fit for their intended purpose and reflect a deep understanding of how knowledge, competence and culture enables people, individually and corporately, to deliver and receive health and care within a complex socio-technical environment (Carthey 2013; Care Quality Commission 2016).

The early thinking on the people perspective focused primarily on diversity in the patient and carer population. However, it became evident in the *systems* workshop that a wider view was required. As a result, the people perspective was illustrated by descriptions of the range of capabilities evident in the population that might impact their ability to engage with health and care, and a reminder that the location for care delivery can have a significant impact on the relevance of improvements proposed (Figure 15).

Reflection from all the workshops led to the definition of key questions and related topics to describe the essence of the people perspective (Figure 16):

- (i) *Identify* – Who will use the system?
- (ii) *Locate* – Where is the system?
- (iii) *Situate* – What affects the system?

The original, rather simplistic, description of a people perspective was expanded to include elements labelled *identify*, *locate* and *situate*. Further insights and reading on the people perspective may be found in Annex 3 of the *Engineering Better Care* report (Clarkson *et al.* 2017).

### 6.5. An integrated view

The final workshop was attended by 15 healthcare specialists, ten engineers, two patient representatives and the Academy secretariat. It began with an introduction to the whole programme and feedback from the earlier workshops. Exercises to elicit examples of good improvement practice, a vision of a future health service and a map of stakeholders were followed by a discussion to identify effective routes to dissemination.

Following the workshops, the author spent many months drafting a final report, with initial efforts focused on defining an appropriate structure, soliciting case studies to illustrate the application of a systems approach and developing an understanding of the relative merits of healthcare improvement and engineering approaches in delivering a systems approach in practice.

The emerging description of a systems approach was defined by reference to the questions raised by the individual *systems*, *design*, *risk* and *people* perspectives and their integration with a number of basic project management questions:

- (i) *Trigger* – Why are we doing this?
- (ii) *Purpose* – What is the purpose?
- (iii) *Team* – Who should be involved?
- (iv) *Success* – What does good look like?
- (v) *Plan* – What should we do next?

The consensus from the workshops was to focus on key questions describing the approach rather than specific activities that might deliver such an approach, where questions have a greater chance to change thinking. The questions were consolidated to eliminate repetition and integrated with the project management questions. In addition, they were overlaid as coloured *spots*, referencing each of the four perspectives and project management (*systems* – green, *design* – red, *risk* – amber, *people* – blue, and *management* – purple), on a range of traditional healthcare and engineering improvement models to explore the different messages that these visual representations might convey (Figure 17).

Of all of these, the *spiral* model, derived from naval architecture design (Evans 1959) and used extensively in software engineering (Boehm 1988), was judged to be the most effective in communicating the natural order of the questions and their iterative nature (Figure 18).

This representation on its own presented a rather too *perfect* view of a systems approach and did little to hint at how it might be used in practice. Health and care professionals were more used to a linear improvement process (Langley *et al.* 2009; Bevan, Plsek & Winstanley 2013; Health Foundation 2013), typified as one that transforms *current performance* into something *measurably better* (Figure 19). This approach is common to all improvement processes with a focus on the critical stages required for success:

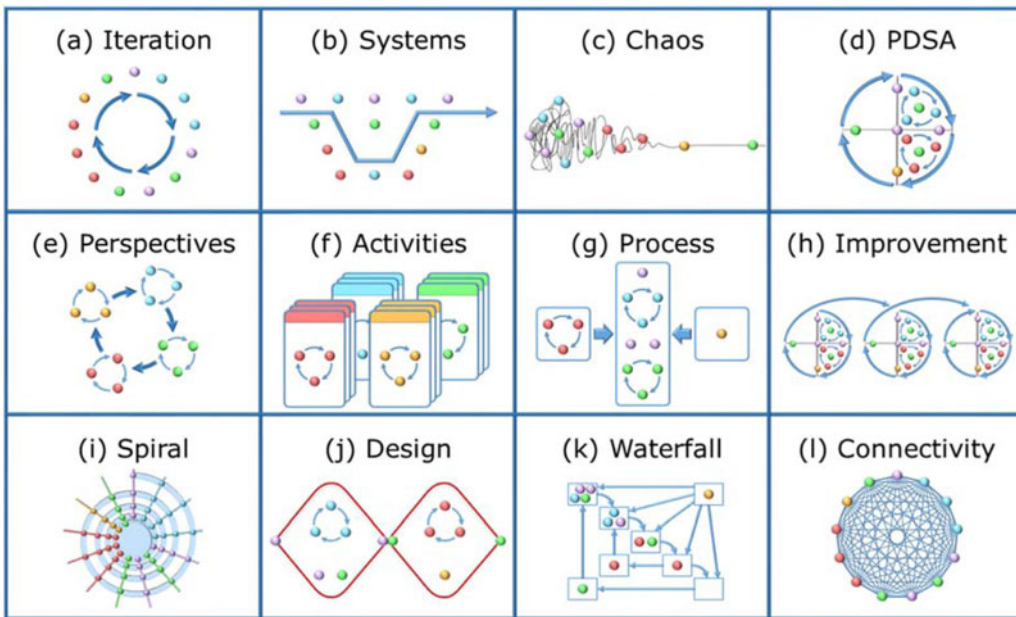

**Figure 17.** A systems approach as a combination of *people, systems, design* and *risk* activities overlaid on a range of healthcare and engineering models of improvement and design: (a) simple iterative cycle; (b) systems engineering V-model; (c) design thinking scribble; (d) plan–do–study–act model for change; (e) clustered model of perspectives; (f) activity-based model of design; (g) sequential process view of design; (h) model of continuous improvement; (i) naval architecture design spiral; (j) double diamond model of design; (k) waterfall model of design; and (l) total product life cycle model.

- (i) *Understand* – leading to a description of the current system (now), a common understanding of the problem, a consensus view of what the future system might look like (better) and a clearly articulated case for changing the system;
- (ii) *Design* – leading to a clear description of the future system, based on the iterative design of the system architecture with its elements and interfaces, the evaluation through successive prototyping of its likely behaviour, and a plan for its delivery;
- (iii) *Deliver* – leading to the successful deployment of the new system with the levels of measurement necessary to evidence its success, and acceptance that it achieves appropriate value for its stakeholders;
- (iv) *Sustain* – leading to the continued operational success of the new system along with consideration of further improvement potential or wider deployment.

The improvement and systems models were combined to generate a helical spiral of health and care improvement (Figure 20). This translation went some way towards translating the description of a systems approach (*What?*) into a practical implementation guide (*How?*) that resonated with health and care improvement specialists. However, further work was required to develop a toolkit that would be sufficient to transform this potential for improvement into practice.

A summary of the value of the proposed systems approach may best be articulated by a number of observations from the workshops:



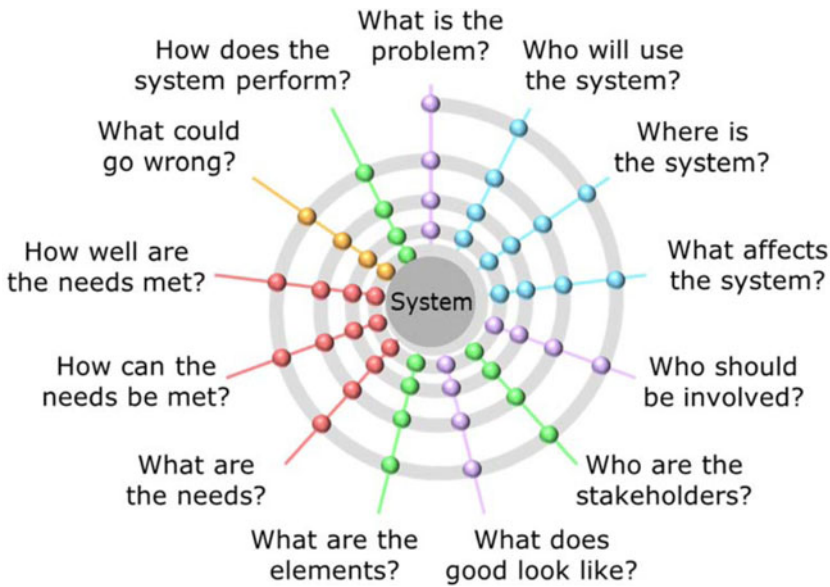

**Figure 18.** A systems approach as a spiral model of the questions that define an iterative approach to health and care improvement.

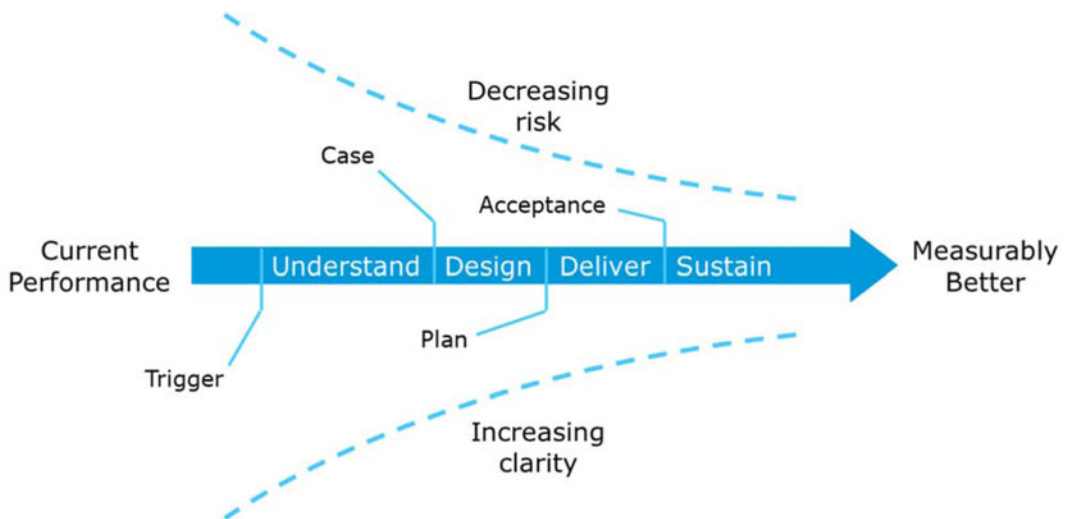

**Figure 19.** A linear improvement process transforming current performance into a measurably better state, through stages to understand, design, deliver and sustain the future system.

- (i) *Engineers think about people* – a surprise from the health and care perspective that a systems approach is people-focused (people);
- (ii) *Iteration before implementation* – engineers typically iterate to find adequate solutions to challenges before their implementation (systems);
- (iii) *Design is an exploratory process* – engineers develop a variety of potential solution concepts from which the best is then selected (design);



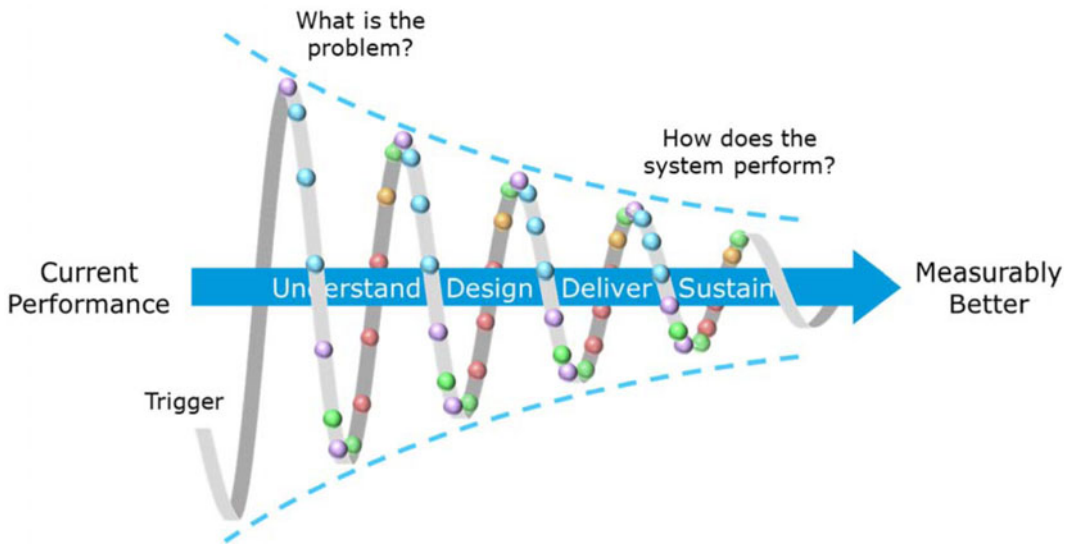

**Figure 20.** A systems-spiral improvement process transforming current performance into a measurably better state, through the application of an ordered and iterative set of activities drawn from *people, systems, design* and *risk* perspectives on a systems approach.

- (iv) *Risk management is a proactive process* – engineers prefer to manage risks proactively to design out faults before they happen (risk);
- (v) *Thinking changes practice, process helps* – a systems approach posed as a series of questions has real potential to change behaviour;
- (vi) *Common sense is not common* – while there may be nothing new in a systems approach, islands of excellence are surprisingly rare.

Success is dependent on bringing together the strengths of an engineering systems approach with the established practice of health and care improvement. It requires a delicate balance of *systems, design, risk* and *people* perspectives by those expert in appropriate areas of clinical and/or care practice, improvement methods and a systems approach (Figure 21).

## 7. A case study of improvement

The key messages contained within the *Engineering Better Care* report (Clarkson *et al.* 2017) have been presented at a number of national and international health and care improvement events. Feedback has been universally positive, with calls to translate the narrative description of a systems approach from the report (*What?*) into a practical implementation guide (*How?*). However, a common question at such events has been whether the systems approach has been usefully applied to practical cases. The answer is *yes*, although many applications by the author and colleagues predate the *Engineering Better Care* report. However, work done for the then UK National Patient Safety Agency (NPSA), in response to the challenge of improving the safety of patients using oral methotrexate for the treatment of rheumatoid arthritis, did follow a systems approach (Ward, Clarkson & Buckle 2004). The answers that follow represent those that may have been formulated at



**Figure 21.** A successful systems approach may be compared to that of a juggler where a successful performance relies on keeping all the balls in the air.

the time, accepting that there was some iteration between the *systems*, *design*, *risk* and *people* elements of the work.

### 7.1. Why are we doing this?

In 2000, a Cambridgeshire patient died as a direct result of failures in her care and treatment (Cambridgeshire Health Authority 2000). The patient had been taking a *weekly* dose of methotrexate when her prescription had been altered in error by her GP to a *daily* dose. The patient had then inadvertently overdosed on methotrexate and was later admitted to hospital where they died. An inquiry into her death highlighted the need to review the use of oral methotrexate for the treatment of rheumatoid arthritis.

### 7.2. What is the problem?

Of the 13 000 medicines licensed for use in the UK at that time, oral methotrexate was one of only six that should have been taken weekly. Previously, 25 deaths and 26 cases of serious harm had been attributed to the incorrect use of methotrexate.

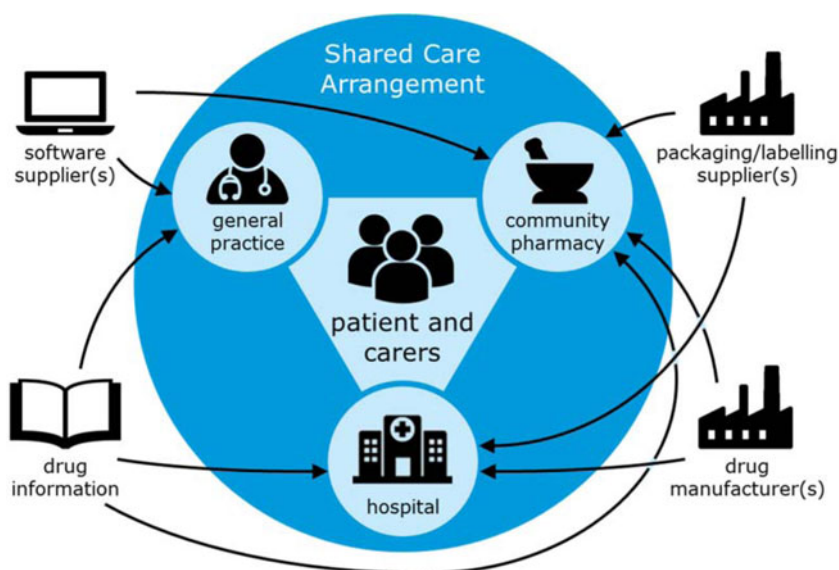

**Figure 22.** Methotrexate used for the treatment of patients with rheumatoid arthritis is administered and controlled in the UK using a shared care arrangement, involving GPs, community pharmacies and hospitals. Other organisations supply the drug, packaging and labelling, prescribing and dispensing software, and drug information.

### 7.3. Who will use the system?

People who are actively *using* the system are those within the Shared Care Arrangement (Figure 22), such as patients with rheumatoid arthritis, their carers, GPs, pharmacists, phlebotomists and hospital doctors.

### 7.4. Where is the system?

The system is in the UK and spans from the home to general practice to the community pharmacy to the hospital, working under a shared care arrangement (Figure 22).

### 7.5. What affects the system?

There are three suppliers of methotrexate for the UK market. They provide 2.5 mg and 10 mg tablets in 100 tablet bottles that are very similar in colour and size, and 2.5 mg tablets in blister packs containing 28 tablets.

### 7.6. Who should be involved?

People should be involved in the improvement programme if they are engaged in the supply, management and control of oral methotrexate in the UK. They might include patients and carers, community pharmacies, GPs and hospital doctors, drug manufacturers, drug prescription and dispensing software vendors, and information providers and packaging designers.

## 7.7. Who are the stakeholders?

Stakeholders are those who have an interest in the successful performance of the system. A sample of the stakeholders from the full report are described here by their role title, need(s) and purpose:

**As a patient I need** sufficient methotrexate **so that** I have relief from the pain resulting from my rheumatoid arthritis, **I need** methotrexate in an easy-to-open pack **so that** I am able to open the pack and retrieve the correct dose, and **I need** to be confident that I am taking the correct dose of methotrexate **so that** I do not suffer adverse effects from the drug.

**As a general practitioner I need** to ensure that the patient knows how to administer methotrexate **so that** there is no chance of the patient taking the wrong dose, **I need** to be sure that I prescribe the correct dose of methotrexate **so that** there is no chance of the patient taking the wrong dose, and **I need** to ensure that the patient's bloods are monitored **so that** the dose can be controlled.

**As a hospital doctor I need** to understand the particular challenges of oral methotrexate use **so that** I am able to recognise the needs and potential problems experienced by these patients.

**As a drug manufacturer I need** to supply methotrexate in a form **so that** pharmacies can adjust the quality dispensed to meet individual patient needs, and **I need** to sell sufficient quantity of methotrexate **so that** the product line is commercially viable.

**As a pharmacist I need** to dispense methotrexate in a timely way **so that** the patient always has the medication they need, and **I need** to ensure that the patient understands the particular restrictions on the use of methotrexate **so that** they are kept safe.

**As a carer I need** to know that the patient understands the importance of taking the correct dose of methotrexate **so that** they remain safe, and **I need** to be sure that methotrexate is not confused with other medications **so that** they remain safe.

**As a software supplier I need** to deliver competitive prescribing and dispensing systems **so that** GPs/pharmacists use my software, and **I need** to ensure that my products enhance GP/pharmacist practices **so that** errors are reduced.

**As an information supplier I need** to ensure that information is trustworthy and accessible **so that** GPs/pharmacists use my services, and **I need** to ensure that my services enhance GP/pharmacist practices **so that** errors are reduced.

**As a packaging/labelling supplier I need** to provide clear identification **so that** the pharmacist and patient can unambiguously select the correct medication.

## 7.8. What does good look like?

Success will be measured by a significant reduction of deaths and serious injury to patients being treated with oral methotrexate for rheumatoid arthritis, while maintaining the benefits of disease and symptom control.

## 7.9. What are the elements?

The management of patients taking oral methotrexate is organised using a Shared Care Arrangement, sharing responsibility for safe care between the general practice, the community pharmacy and the hospital (Figure 22).

## 7.10. What are the needs?

The needs for redesign of the system are dominated by the needs of the patient, where the priority is for an easy-to-follow medication management process, easy-to-understand information about methotrexate, easy-to-identify medication and easy-to-open packs. Other needs, derived from the stakeholders' list, were also be considered in the context of meeting the fundamental patient needs.

## 7.11. How can the needs be met?

In response to the patient needs, a number of potential solutions were identified which had the potential to prevent harm, based upon the causal and contributory data available at the time:

- (1) better information for the patient prior to treatment and use of patient-held records to include monitoring schedules and results;
- (2) clear branding of oral methotrexate as a weekly medication with clear instructions to take methotrexate on Mondays;
- (3) improved warnings and flags for GP prescribing and pharmacy dispensing software systems which were not easily over-ridden;
- (4) reshaped tablets from manufacturers to ensure that 2.5 mg round tablets are easily distinguishable from 'new' 10 mg torpedo shaped tablets;
- (5) repackaged tablets using novel designs and in reduced quantities so that the patient receives the original manufacturers pack.

## 7.12. How well are the needs met?

A new information leaflet for patients, emphasising the weekly dose for methotrexate, was drafted and trialled. This led to the provision of a methotrexate treatment guide incorporating a pre-treatment leaflet designed to provide patients with guidance on low dose methotrexate and a blood monitoring and dosage record booklet.

The changes proposed for the shape of the methotrexate tablets were delivered, but this did not address potential confusion with other medications and, in particular, folic acid which is often prescribed with methotrexate.

Software vendors provided enhancements to their existing GP prescribing software to ensure oral methotrexate was clearly labelled, highlighting the need for weekly doses and providing dosing options that clearly articulated the number of tablets to be taken.

Novel packaging designs were not pursued at this stage. However, manufacturers began to provide tablets in 16 and 24 packs with improved design, labelling and safety information. The use of existing pharmacy labels continued.

### 7.13. What could go wrong?

A review of the risks associated with the oral methotrexate system was undertaken prior to determining the design interventions described above. Risks included:

- (i) the GP prescribing methotrexate 'as directed';
- (ii) the patient receiving the wrong dose due to confusion between different strengths of methotrexate tablets;
- (iii) the patient receiving the wrong dose due to confusion between folic acid and methotrexate tablets;
- (iv) the pharmacist dispensing the incorrect prescription to the patient because of poor design of prescribing/dispensing software;
- (v) the pharmacist only writing the total dose of methotrexate, not the number of tablets to be taken.

Many of these issues were addressed by the design changes proposed and other patient safety initiatives. However, a number remained, including the potential for patients to be confused by the two strengths of methotrexate tablets which led to the policy in many regions to prescribe only 2.5 mg tablets.

### 7.14. How does the system perform?

Limited data was collected to enable direct comparison with previous error rates. Communications from the NPSA suggested that early compliance with new guidance remained poor, likely contributing to ongoing errors in the use of methotrexate and resulting in patient harm. Despite all the best efforts of the improvement team, methotrexate remains a potentially harmful drug that is ultimately administered by the patient.

### 7.15. What should we do next?

The use of oral methotrexate as an effective treatment for rheumatoid arthritis relies on a number of systems working with the patient to ensure their safety. Further improvements in the use of this drug will need to follow a systems approach to ensure that key stakeholders work together to clearly identify and implement changes that would continue to minimise future loss of life.

A more complete account of this study may be found in Annex 1 of the *Engineering Better Care* report (Clarkson *et al.* 2017) and details of the patient death and that triggered the NPSA project are available in the report on the subsequent inquiry (Cambridge Health Authority 2000).

## 8. Postscript

The challenge of translating the description of a systems approach (*What?*) into a practical implementation guide (*How?*) should not be underestimated. Such translational research is time consuming and requires a range of different skills. The simple aspiration to develop a Healthcare Design Toolkit (Figure 23) masks the complexity of co-designing a framework and tools to incorporate a systems approach within health and care improvement.

The Healthcare Design Toolkit can itself be designed using a systems approach, identifying the key stakeholders and their needs alongside a description of its intended purpose, where its primary goal is to deliver health and care





**Figure 23.** A Healthcare Design Toolkit to assist the delivery of health and care improvement.



**Figure 24.** Health and care improvement defined by key questions.

improvement (Figure 20). Identifying the potential users of the toolkit is essential, but complicated by the fact that some may be health and care professionals with extensive prior experience of existing quality improvement approaches, while others may be systems engineers with limited clinical and care experience. Achieving improvement is a complex undertaking and it is unlikely that the toolkit can be used by those who have no prior improvement experience. It is not the purpose of the toolkit to make improvement *simple*, rather to make it *effective*, transforming current performance to something measurable better, guided by a number of key questions (Figure 24).

Effective improvement is defined by a clear understanding of *current performance*, a consensus view of what is *measurably better* and, most importantly, a viable *case for change*. Without such a case, improvement is unlikely to proceed, regardless of the potential benefits to patients, practitioners, carers or the public. Consequently, development of the toolkit focused on the early stages of improvement which would lead to the definition of the *case for change* (Figure 25). The *scoping* and *understanding* activities are likely to be iterative and the resulting case for change should rely on the conceptual design of the system to define those improvements that would be most likely to lead to performance that is *measurably better*.

The conceptualisation of the toolkit was influenced by improvement projects with a number of UK Hospital Trusts, where the *scoping* and *understand* stages typically took the form of meetings and workshops (Figure 26). Careful planning of these interventions, specifically to incorporate the *management, people* and

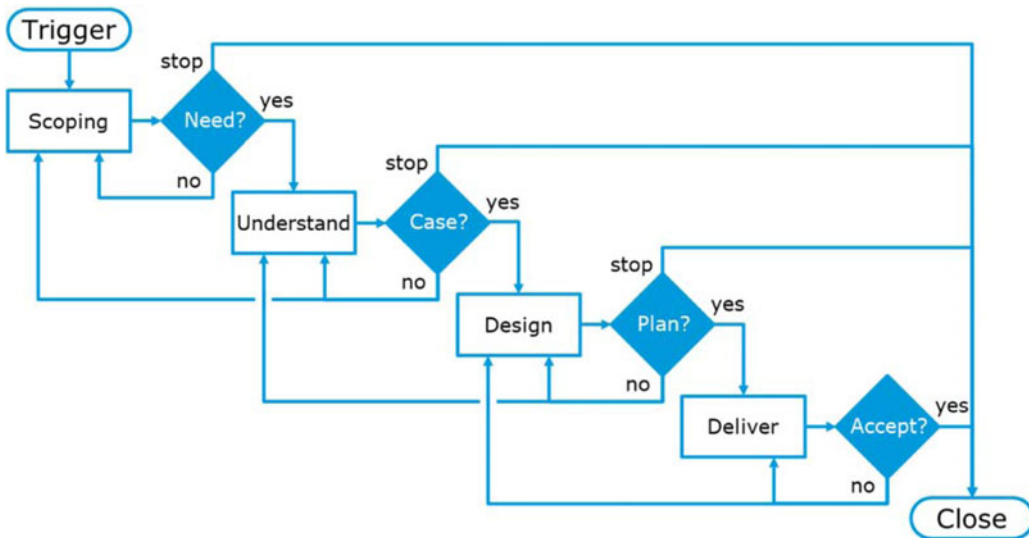

Figure 25. An iterative process of improvement focused on delivering a *case for change*.

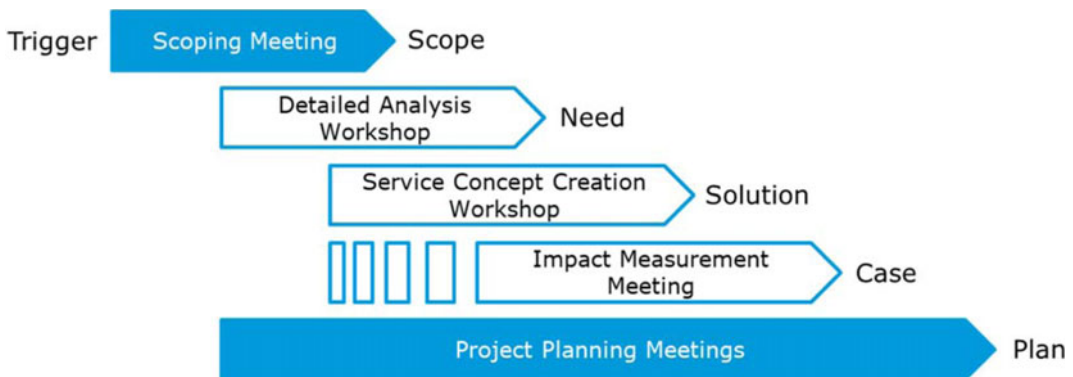

Figure 26. A series of choreographed meetings focused on delivering a *case for change* founded on a proposed solution to an identified need.

*systems* questions from the systems approach (Figure 18) and analysis of available performance data, was essential to agree the scope of the project, elicit an understanding of the current performance and develop a case for change.

This pragmatic approach to improvement illustrates the need to go beyond the simple provision of tools, and to deliver realisable activities that are bespoke to particular improvement opportunities and sympathetic to the time challenges faced by operational units. A toolkit needs to provide a framework for improvement that draws on the best of health and care and engineering approaches, guiding teams to deliver benefit to patients, carers and health service staff. To accomplish this, it must support the needs of key potential users, whether they be clinicians, service managers, project managers, service commissioners or service users. This is not a simple requirement, but one that requires careful consideration, accompanied by iterative development, to enable such *users* to



**Figure 27.** The toolkit as a targeted framework for change.

follow *processes*, informing *plans* which identify *activities* using *tools* which need appropriate *support*, to deliver change (Figure 27). Success will depend on the combined expertise of engineers, health and care practitioners and improvement specialists to deliver a realistic framework for sustainable change.

Projects are currently underway to co-develop bespoke toolkits for designing palliative care systems, improving surgical care for older people, and delivering sustainable improvements to trauma care in low and middle income countries. These typically comprise a set of cards, linked to further guidance, that cover a range of topics: a systems approach; toolkit users; service users; service stakeholders; case for change; programme of change; performance measures; improvements models; improvement processes; improvement activities; improvement tools; and case studies (Figure 28). Such cards can be used in a variety of scenarios by leaders and facilitators to help explain and drive the improvement process.

Toolkit development brings together engineers, health and care providers, and improvement specialists to ensure that the resulting toolkit is not only fit for its intended purpose, but also that the need for facilitation at different stages of its use is clearly articulated and understood. Toolkits that work do not just happen – they have to be planned, designed and built. They also have to be evaluated to build the evidence base necessary to demonstrate the value of applying a systems approach to health and care improvement.

The *Engineering Better Care* Toolkit, although designed with health and care professionals in mind, has its origins in a much broader range of potential applications and, as a result, could be adapted for use in many other areas. The concepts behind the toolkit, drawn from the *Engineering Better Care* report, also have particular potential in introducing a systems approach to other professions. However, caution is necessary in any such adaptation since the skills required are expansive, ranging from research to knowledge transfer and from improvement expertise to knowledge of actual practice.

The development of an effective toolkit represents a particular challenge for researchers, a challenge long recognised by NASA in their description of

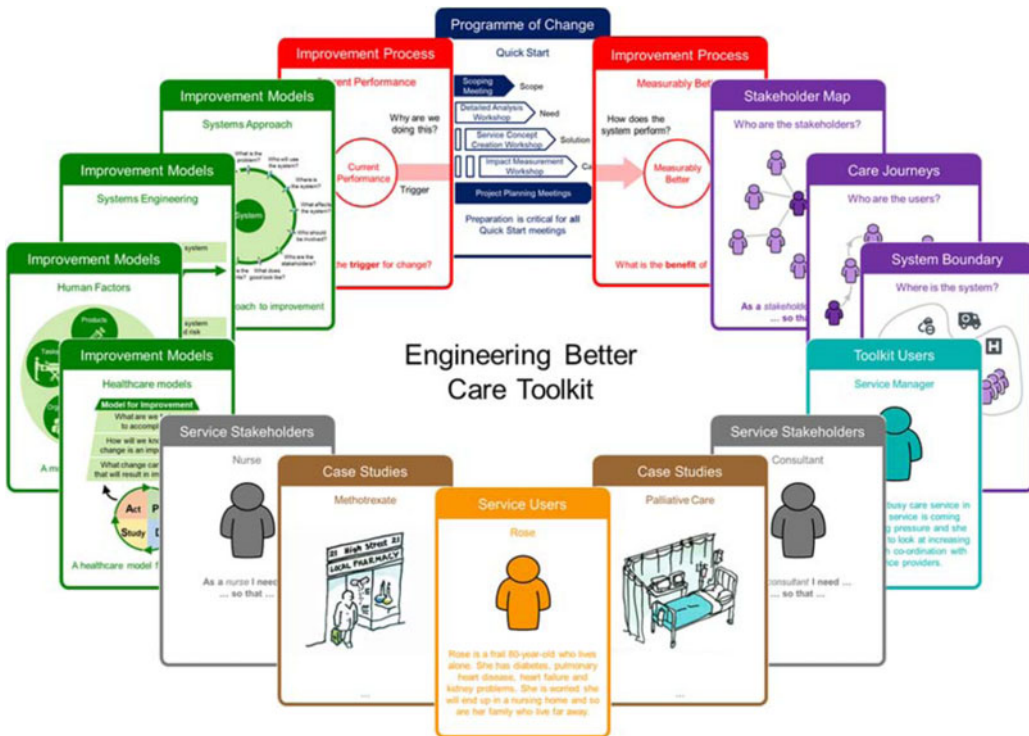

Figure 28. The toolkit as a set of cards, or prompts, for change.

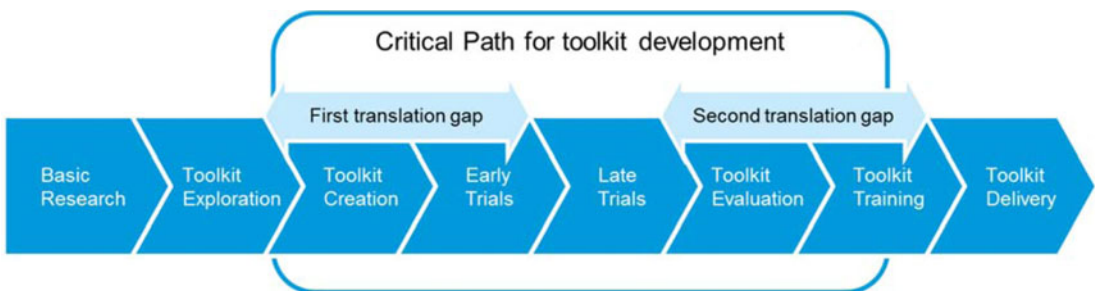

Figure 29. Toolkit development challenges, adapted from Cooksey (2006).

Technology Readiness Levels (Mankins 2009) and the process of translating research into sustainable practice. Different skills are required at each stage to create appropriate outcomes and generate adequate rewards for all stakeholders. Transformation in health and care is known to bring similar challenges, often described as translation gaps, when moving between clinical research and clinical trials and between clinical trials and delivery into clinical practice (Cooksey 2006). This latter description translates well into a model for toolkit development (Figure 29), accepting that a linear model necessarily does not highlight the iteration present in such processes.

Design research, as described by methodologies such as the Design Research Methodology (Blessing & Chakrabarti 2009), actively encourages the bridging of the first translation gap from basic research to late trials. Indeed, a significant proportion of the research reported from the design research community presents work in this area.

The second translation gap is more troublesome, requiring exceptional access to practitioners and the particular skills and time necessary to operate in this area, attributes less often found in academic research groups. In consequence, it is likely that a group that is able to employ, or partner researchers with, translational specialists, for example, those with a background in technology consulting, engineering projects, change management or transformation, will be more successful in delivering research into sustained practice. A widely used and effective alternative is to deliver well trained design researchers into practice, and encourage them to take their best ideas with them in an effort to cross the second translation gap. However, the critical path for toolkit development (Figure 29) encompasses both translation gaps, and knowledge or experience of the second gap should influence attempts to bridge the first.

The author has had the privilege, over a number of years, to build two linked teams within the Cambridge Engineering Design Centre: (1) a research team tasked to undertake basic research and address the first translation gap; and (2) a knowledge transfer team with personal experience of practice, tasked to address the second translation gap. The mistake is to think that the same people can fulfil both roles – in general they cannot. However, the two teams can work closely together, often engaged on the same projects, not only to ensure that basic research is informed by actual practice, but also to maximise the opportunity of translating ideas from basic research into practice.

Success requires both teams to be totally dedicated to their common task, exploiting all the freedoms that universities offer to be creative and enterprising in the pursuit of excellence. Unfortunately, funding both teams simultaneously is a significant challenge, as is the need to persuade universities to develop career paths for knowledge transfer specialists alongside those already established for researchers. When this situation changes, may be the design research community will see more of their basic research translated into tools that have a significant impact on design practice.

## 9. Conclusions

A systems approach has long been used in engineering to successfully deliver products and services across a wide range of applications, from the simple to the complex, and in this context it is widely acknowledged that ‘systems that work do not just happen – they have to be planned, designed and built.’

This paper has reported on the career of the author, reflecting on how it influenced a project led by the Royal Academy of Engineering to explore the potential for applying a systems approach to the delivery of health and care. This endeavour, where engineers, clinicians, and healthcare leaders joined in conversation to discuss how an engineering systems approach could be adapted to meet the needs of patients, carers and health service staff, resulted in the development of a new framework to support existing work in service design and improvement in health and care.

The contribution of this work lies not only in the co-development of a framework for improvement, but also in the articulation of a systems approach as a collection of *people, systems, design* and *risk* perspectives expressed in the form of simple questions. An iterative spiral model, inspired by the naval architecture design spiral, overlays this set of questions on a typical health and care quality improvement process.

The approach presented in this paper, and delivered as a Royal Academy of Engineering report, has so far been well received by health and care professionals and engineers. The work continues, facilitated by a multidisciplinary group of researchers and transformation specialists, to translate this narrative description of a systems approach (*What?*) into a practical implementation guide and toolkit (*How?*), supported by evidence of its effective use in health and care improvement practice.

A lifetime spent learning how to engineer complex systems, supported by practical challenges and the academic freedom to explore without boundaries, is a rare privilege. The chance to *Engineer Better Care* is rarer still and provides the ultimate opportunity for someone who was simply diagnosed many years ago as having ‘The Knack’ (Petroski 2007).

### Acknowledgments

The project that led to majority of the work described in this paper was led by the Royal Academy of Engineering with assistance from the Royal College of Physicians and the Academy of Medical Sciences. Particular thanks are due to all those health and care professionals and engineers who attended workshops and commented on the *Engineering Better Care* report.

Thanks are also due to the author’s colleagues in the Cambridge Engineering Design Centre who have contributed over many years to the development of the thinking and tools that influenced the *Engineering Better Care* report and equally provided the practical expertise necessary to design the *Engineering Better Care* toolkit, most notably James Ward, Alexander Komashie, Ian Hosking and Terry Dickerson. Financial support has also been provided by the National Institute for Health Research (NIHR) East of England Collaboration for leadership in applied health research and care (CLAHRC).

### References

- Armitt, J.** 2011 *Engineering the Olympics: The 2011 Lloyd’s Register Educational Trust Lecture*. Royal Academy of Engineering.
- Berwick, D.** 2013 *Improving the Safety of Patients in England*. Department of Health.
- Bevan, H., Plsek, P. & Winstanley, L.** 2013 *Leading Large Scale Change: A Practical Guide*. NHS Institute for Innovation and Improvement.
- Blessing, L. T. M. & Chakrabarti, A.** 2009 *DRM, a Design Research Methodology*. Springer, ISBN: 978-1-84882-587-1.
- Boehm, B. W.** 1988 A spiral model of software development and enhancement. *Computer* 21 (5), 61–72.
- Bristol Royal Infirmary** 2001 *Learning from Bristol – The Report of the Public Enquiry into Children’s Heart Surgery at the Bristol Royal Infirmary 1984–1995*. Secretary of State for Health.



- British Standards** 2009 *BS ISO 31000:2009 Risk Management – Principles and Guidelines*. British Standards.
- Cambridge Health Authority** 2000 *Methotrexate Toxicity – An Inquiry into the Death of a Cambridgeshire Patient in April 2000*. Cambridgeshire Health Authority.
- Care Quality Commission** 2016 *Better Care in My Hands: A Review of How People are Involved in their Care*. Care Quality Commission.
- Carthey, J.** 2013 *Implementing Human Factors in Healthcare: Taking Further Steps*. Clinical Human Factors Group.
- Clarkson, P. J. & Acarnley, P. P.** 1988 Stability limits for the dynamic operation of variable-reluctance stepping motor systems. *Institution of Electrical Engineers Proceedings Part B* **135** (6), 308–317.
- Clarkson, P. J. & Acarnley, P. P.** 1989 Simplified approach to the dynamic modelling of variable-reluctance stepping motors. *Institution of Electrical Engineers Proceedings Part B* **136** (1), 1–10.
- Clarkson, P. J. & Coleman, R.** 2015 History of inclusive design in the UK. *Applied Ergonomics* **46** (Part B), 235–247.
- Clarkson, P. J. & Hamilton, J. R.** 2000 ‘Signposting’, a parameter-driven task-based model of the design process. *Research in Engineering Design* **12** (1), 18–38.
- Clarkson, P. J., Bogle, D., Dean, J., Tooley, M., Trewby, J., Vaughan, L., Adams, E., Dudgeon, P., Platt, N. & Shelton, P.** 2017 *Engineering Better Care: A Systems Approach to Health and Care Design and Continuous Improvement*. Royal Academy of Engineering, ISBN: 987-1-1909327-35-1.
- Clarkson, P. J., Buckle, P., Coleman, R., Stubbs, D., Ward, J. R., Jarrett, J. P., Lane, R. & Bound, J.** 2004a Design for patient safety: a review of the effectiveness of design in the UK health service. *Journal of Engineering Design* **15** (2), 123–140.
- Clarkson, P. J., Simons, C. S. & Eckert, C. M.** 2004b Predicting change propagation in complex design. *ASME Journal of Mechanical Design* **126** (5), 788–797.
- Cooksey, D.** 2006 *A Review of UK Health Research Funding*. HM Treasury.
- Cowper, D., Kemp, D., Elphick, J. & Evans, R.** 2014 To V or not to V – that MUST be the question: knowing when to apply the right approach. In *INCOSE International Symposium, June 30–July 3, Las Vegas, NV*, Wiley.
- Department of Health & Design Council** 2003 *Design of Patient Safety: A System-wide Design-led Approach to Talking Patient Safety in the NHS*. Department of Health Publications, 32768.
- Design Council** 2007 *Eleven Lessons Managing Design in Eleven Global Companies: A Study of the Design Process*. Design Council.
- Elliott, C. & Deasley, P.** (Eds) 2007 *Creating Systems that Work: Principles of Engineering Systems for the 21st Century*. Royal Academy of Engineering, ISBN: 1-903496-34-9.
- Erwin, K. & Krishnan, J. A.** 2016 Redesigning healthcare to fit with people. *BMJ* **354** (i4536).
- Evans, D. E. & Sheehan, M. C.** 2002 Don’t be fobbed off: the substance of beer foam – a review. *Journal of the American Society of Brewing Chemists* **60** (2), 47–57.
- Evans, J. H.** 1959 Basic design concepts. *Journal of the American Society of Naval Engineers* **71** (4), 671–678.
- Greene, M., Gonzalez, R., Papalambros, P. & McGowan, A. M.** 2017 Design thinking vs. system thinking for engineering design: what’s the difference? In *Proceedings of the International Conference on Engineering Design, August 2017, Vancouver, Canada*, The Design Society.

- Ham, C., Berwick, D. & Dixon, J.** 2016 *Improving Quality in the English NHS: A Strategy for Action*. The King's Fund.
- Hamraz, B., Caldwell, N. M. H. & Clarkson, P. J.** 2013 A multidomain engineering change propagation model to support uncertainty reduction and risk management in design. *ASME Journal of Mechanical Design* **134** (10), 14pp.
- Health Foundation** 2013 *Quality Improvement Made Simple: What Everyone Should Know about Health Care Quality Improvement*. The Health Foundation.
- Hollnagel, E., Wears, R. L. & Braithwaite, J.** 2015 *From Safety-I to Safety-II: A White Paper*. The Resilient Health Care Net, doi:[10.13140/RG.2.1.4051.5282](https://doi.org/10.13140/RG.2.1.4051.5282).
- Horberty, T., Teng, Y. C., Ward, J. R., Patil, V. & Clarkson, P. J.** 2014 Guidewire retention following central venous catheterisation: a human factors and safe design investigation. *International Journal of Risk and Safety in Medicine* **26** (1), 23–37.
- Hosking, I. M., Cornish, K., Bradley, M. D. & Clarkson, P. J.** 2014 Empathic engineering: helping deliver dignity through design. *Journal of Medical Engineering and Technology* **39** (7), 388–394.
- Hosking, I. M., Waller, S. D. & Clarkson, P. J.** 2010 It is normal to be different: applying inclusive design in industry. *Interacting with Computers* **22** (6), 439–614.
- Hussain, S. & Dornhurst, A.** 2016 *Integrated Care – Taking Specialist Medical Care beyond the Hospital Walls*. Royal College of Physicians.
- INCOSE** 2009 *UK Z-Guide 1: What is Systems Engineering: Creating Successful Systems*. International Council on Systems Engineering.
- INCOSE** 2014 *A World in Motion: Systems Engineering Vision 2025*. International Council on Systems Engineering.
- Keates, S. & Clarkson, P. J.** 2003 *Countering Design Exclusion – An Introduction to Inclusive Design*. Springer, ISBN: 1-85233-699-4.
- Koln, L. T., Corrigan, J. M. & Donaldson, M. S.** (Eds) 2000 *To Err is Human*. The National Academy Press, ISBN: 0-309-06837-1.
- Kurtz, C. F. & Snowden, D. J.** 2003 The new dynamics of strategy sense-making in a complex world. *IBM Systems Journal* **42** (3), 462–483.
- Langley, G. L., Moen, R., Nolan, K. M., Nolan, T. W., Norman, C. L. & Provost, L. P.** 2009 *The Improvement Guide: A Practical Approach to Enhancing Organizational Performance*, 2nd edn. Jossey-Bass Publishers.
- Leape, L.** 1997 *Human Beings Make Mistakes Because the Systems, Tasks and Processes they Work in are Poorly Designed*. Testimony before the President's advisory Commission on Consumer Protection and Quality in the Health Care Industry, 19 November 1997.
- Lucas, B. & Nacer, H.** 2015 *The Habits of an Improver Thinking about Learning for Improvement in Health Care*. The Health Foundation.
- Mankins, J. C.** 2009 Technology readiness assessments: a retrospective. *Acta Astronautica* **65** (9–10), 1216–1223.
- NASA** 2016 *NASA Systems Engineering Handbook*. NASA Center for Aerospace Information, Hanover, MD, NASA/SP-2016-6105, Rev2, ISBN: 978-1979381475.
- NHS England** 2014 *Five Year Forward View*. NHS England.
- NHS England** 2015a *Five Year Forward View – The Success regime: A Whole Systems Intervention*. NHS England.
- NHS England** 2015b *New Care Models: Empowering Patients and Communities, A Call to Action for a Directory of Support*. NHS England, 04446.
- Petroski, H.** 2007 Diagnosing Dilbert. *ASEE Prism* **16** (8), 22.

- Pronovost, P. J., Ravitz, A. D., Stoll, R. A. & Kennedy, S. B.** 2015 *Transforming Patient Safety, A Sector-wide Systems Approach*. WISH Patient Safety Forum, World Summit for Health, Qatar.
- Reid, P. P., Compton, W. D., Grossman, J. H. & Fanjiang, G.** 2005 *Building a Better Delivery System: A New Engineering/Health Care Partnership*. The National Academy Press, ISBN: 0-309-09643-X.
- Rittel, H. W. J. & Webber, M. M.** 1973 Dilemmas in a general theory of planning. *Policy Sciences* 4 (2), 155–169.
- Snowden, D. J. & Boone, M. E.** 2007 A leader's framework for decision making. *Harvard Business Review* (November), BR0711.
- Vincent, C. & Amalberti, R.** 2016 *Safer Healthcare: Strategies for the Real World*. Springer International Publishing.
- Waller, S. D., Bradley, M. D., Hosking, I. M. & Clarkson, P. J.** 2015 Making the case for inclusive design. *Applied Ergonomics* 46 (Part B), 297–303.
- Ward, J. R., Clarkson, P. J. & Buckle, P.** 2004 *The Packaging and Labelling of Solid Oral Medicines: A Study to Identify the Needs and Functionality for Safe Administration of Solid Oral Medicines Using Oral Methotrexate as an Example*. University of Cambridge/National Patient Safety Agency.
- Ward, J. R., Buckle, P. & Clarkson, P. J.** 2010 Designing packaging to support the safe use of medicines at home. *Applied Ergonomics* 41 (5), 682–694.
- Wynn, D. C., Grebici, K. & Clarkson, P. J.** 2011 Modelling the evolution of uncertainty levels during design. *International Journal on Interactive Design and Manufacturing* 5 (3), 187–202.