

JOHN CRANE (1571–1652); THE CAMBRIDGE APOTHECARY AND PHILANTHROPIST

by

LAURENCE MARTIN*

JOHN CRANE lived in Cambridge for most of his life and died there, a wealthy man, on 26 May 1652 at the age of eighty-one. His name has been kept alive to the present day in Cambridge University by his Charity for paying the medical expenses of poor, sick scholars. The towns of Wisbech, Cambridge, King's Lynn, and Ipswich also received benefactions in his will for setting up young men in business, but his name has long been forgotten in them – except perhaps in Wisbech where he was born – and his charities became merged with others in municipal charitable funds after 1859.

Although Crane was a prominent citizen of Cambridge, High Sheriff of Cambridgeshire in 1641, and a well-known apothecary, very little direct information survives about him. His memory rests upon his posthumous benefactions rather than upon records or recollections of his personality and work. The main source of information about him, his relatives, and friends is his will of 21 June 1651 and two codicils of 20 September 1651 and 21 April 1652.¹ The document is very long and detailed, being full of explanations, precautions, and safeguards to ensure strict compliance with his wishes. It richly deserves the exasperated note written on the copy in the Cambridge University library: "The most complicated, absurd and impracticable of all wills that ever came under the eye of S. Peck. Trin. Coll. 1788". The writer, the Reverend Samuel Peck, a Fellow of Trinity College, had managed the business of Crane's Charity for the University from 1786 to 1790. Nevertheless, the numerous bequests to relatives and friends do enable the construction of a tentative pedigree (Fig. 1) and give some idea of Crane's social circle. Even so, there is a dearth of basic biographical details about him.

* Laurence Martin, M.A., M.D., F.R.C.P., Honorary Consulting Physician, Addenbrooke's Hospital, Cambridge.

This article is an abbreviated version of a pamphlet bearing the same title which was privately printed for the author in 1977 by Newton and Denny, Quayside, Cambridge. Less than one hundred copies were printed and given to those concerned with Cranes' Charity in Cambridge University, to interested friends and to appropriate libraries. The author is most grateful to the Editors of *Medical History* for here providing a wider field of circulation.

CUA indicates Cambridge University Archives which also include CUR, indicating Cambridge University Registry Guard-books which retain their original reference.

¹ CUR. 122. no. 1. Apothecaries ranked as scholars' servants in Cambridge University and were licensed by, and under the jurisdiction of, the Vice-Chancellor, in whose court their wills were proved.

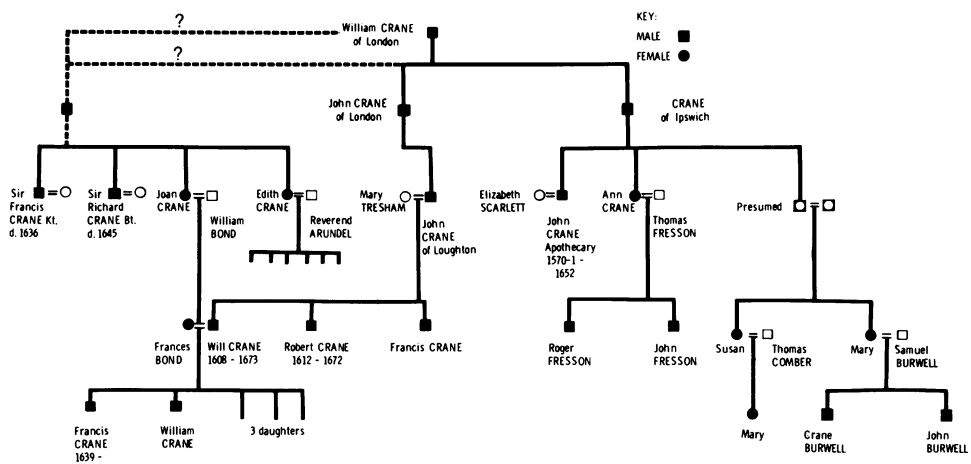

Figure 1.
 Tentative pedigree of John Crane the apothecary, constructed largely from his will.

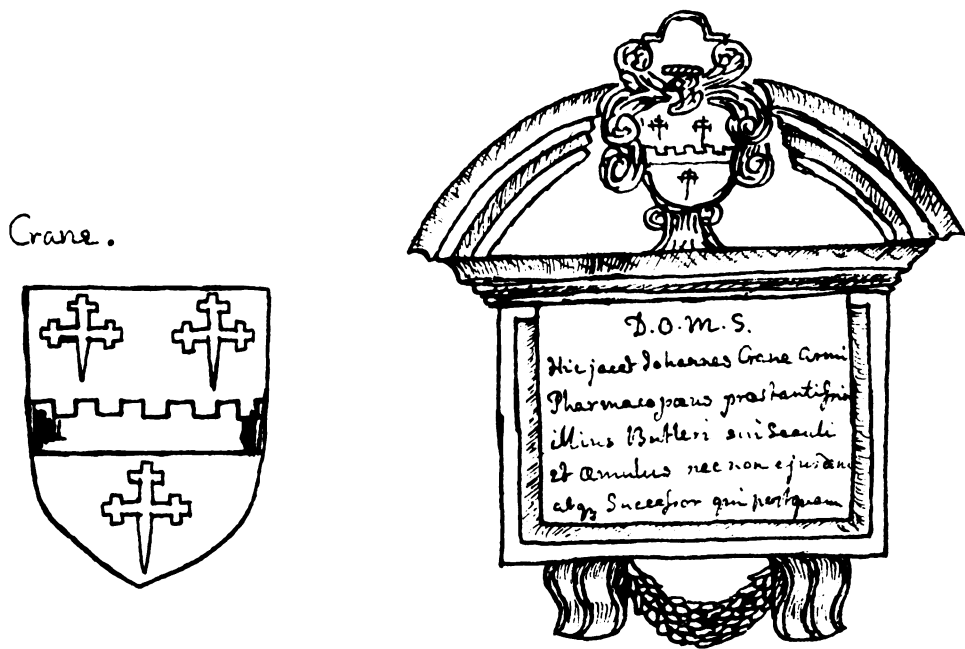

Figure 2.
 Cole's sketch of Crane's monument and coat-of-arms in Great St. Mary's Church, Cambridge.
 (Reproduced by courtesy of the Trustees of the British Museum.)

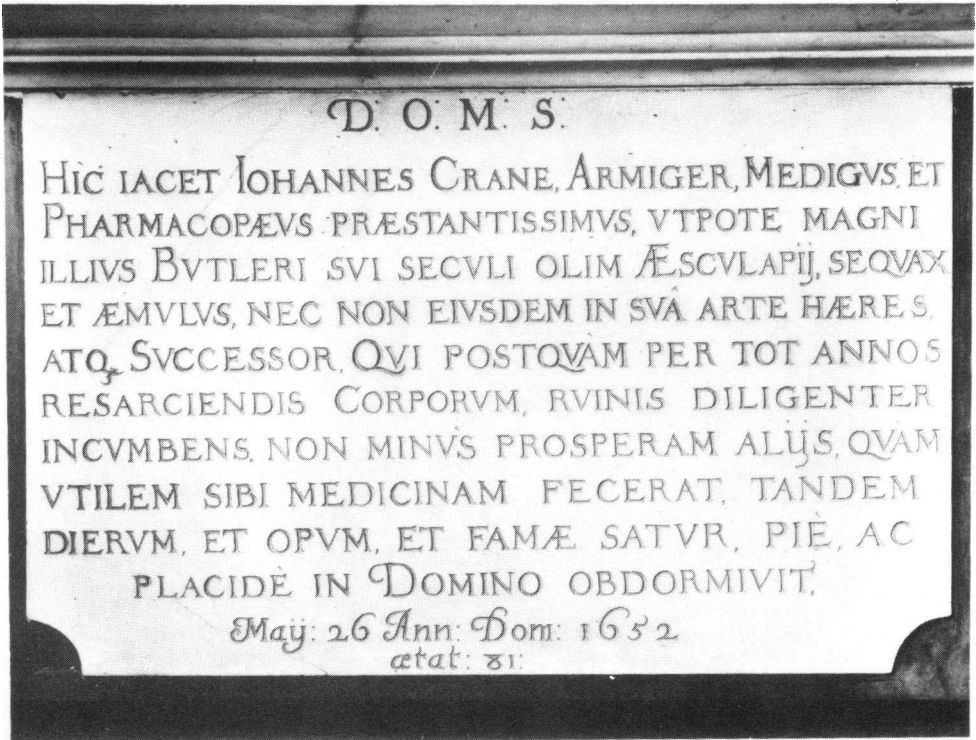

Figure 3.

The marble table (42x24 inches) bearing the inscription from John Crane's monument, which is all that remains today. (Photograph by courtesy of the Vicar of Great St. Mary's Church, Cambridge.)

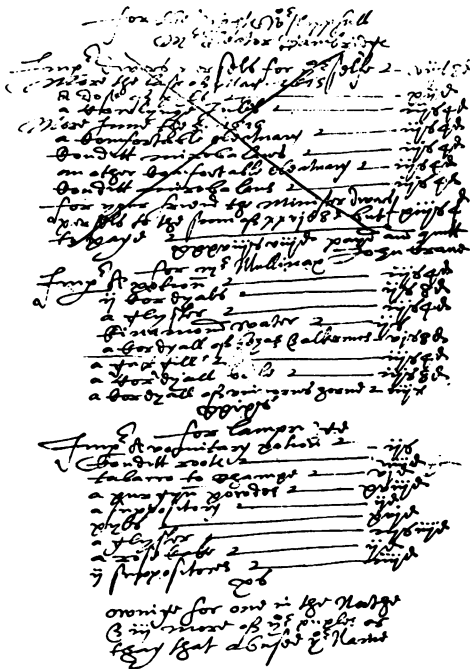

Figure 4.

A bill from John Crane headed 'For the right worshipful Master Doctor Bainbridge'. The upper part applying to the Master is cancelled and receipted "Paid and quitt John Crane". Reproduced by courtesy of the Master and Fellows of Christ's College, Cambridge.

John Crane (1571–1652)

Thus the christian names of his parents are unknown as well as his mother's maiden name, and the only known fact about either parent is that his father was born in St. Matthew's parish at Ipswich, whose records date from 1559. Because John Crane was born in 1570–71 it is likely, on ordinary probabilities, that his father would have been at least twenty years old and hence his own birth would have been not later than 1550, and so unrecorded. Nor do the Wisbech parish records, which commenced in 1558, record any family of Cranes (a not uncommon name in East Anglia) in 1570–71 in which John Crane could be identified. Indeed the date of his birth can only be calculated as lying between 27 May 1570 and 25 May 1571 from the date of his death on 26 May 1652, as recorded on his memorial in Great St. Mary's Church in Cambridge.

The memorial was described by the Reverend William Cole² as “an awkward clumsy mural monument of white marble with these arms at top: viz: *a Fess Crenelle int: 3 Cross Crosslets fitchée for Crane*. The crest is lost. On the Table of white marble surrounded by a bordure of black marble is the following Inscription . . .”. Cole also made sketches of the monument (Fig. 2) and of the arms which are those of the Suffolk Cranes (Fig. 2). The monument was originally placed next to that of Crane's patron, “Dr.” William Butler, on the south side of the chancel but was moved in 1863 and 1892.³ Only the marble table bearing the inscription survives and can be seen at the east end of the north aisle (Fig. 3). A free translation is as follows:

Here lies John Crane, Esquire, pre-eminent Physician and Apothecary, follower and peer of the great Butler himself once the Aesculapius of his age, and indeed the heir and successor of Butler in his art. Devoting himself earnestly for very many years to repairing the ruins of men's bodies, he had practised the art of Healing for the good of others no less than for his own advantage, when finally, full of days and works and reputation, dutifully and peacefully he fell asleep in the Lord. May 26 AD 1652. Aged. 81.

According to his will, Crane had a sister, Ann, and from bequests to two nieces who were not her offspring, he may have had one or two other siblings. Thus, to “my loveing sister Mrs Ann Fresson” he left an annuity of fifty pounds to be paid quarterly “at Trinitie Colledg Hall at the foure most usuall days of the year (i.e. the annunciation of the Blessed Virgin Mary, the nativity of John the Baptist, St Michael the Archangel and the Nativity of our Lord God) in equal portions from the first feast day after my death.” The reasons for this mode and place of payment are obscure and could not be explained by enquiries at Trinity College and at Trinity Hall. But Crane had two cousins who were Fellows of Trinity College, namely William Crane in 1633–39 and Robert Crane in 1637–1672, and it is possible that there was some private and unrecorded arrangement. Ann's husband, Thomas Fresson, was left £20 per annum if he outlived his wife, and the two sons, Roger and John Fresson, received substantial legacies of houses and land in Wisbech and surrounding areas.

As mentioned above, Crane had two nieces, Susan and Mary. The former married Thomas Comber D.D., Master of Trinity College from 1631 to 1645 and Vice-Chancellor of the University in 1631 and 1636. He was ejected from all his prefer-

² William Cole, ADD, 5810, British Library. Indexed G. Gray, Cambridge, Bowes, 1912, p. 25.

³ W. D. Bushell, *The Church of St. Mary the Great, the University Church at Cambridge*, Cambridge, Bowes, 1948, pp. 172–173.

ments in 1645 and imprisoned for having helped to send University plate to the king and for refusing the covenant.⁴ Susan received a very substantial legacy of houses and land in Wisbech which, on her death, was to pass to her daughter, Mary, who also received a legacy of £1,000 in Crane's will. The other niece, Mary, married Samuel Burwell and bore two sons, Crane Burwell, who was the apothecary's godson, and John Burwell. To Mary Burwell Crane bequeathed some 1,700 acres of pasture and land at Elme in the Isle of Ely and the leaseholds from Peterhouse and Bennett College [Corpus Christi], of two houses in Great St Mary's parish. There was also the further provision that the land and houses, mentioned above, which were left to Susan Comber for her life and then to her daughter, Mary, should, in default of heirs to the latter pass to Crane Burwell and John Burwell. This complicated arrangement is one example of John Crane's concern, having no children of his own, to keep his property and land within the family. His two nieces were apparently his closest descendants but Susan had no son and if her daughter, Mary, remained single or had no heir, the alternatives would be the godson, Crane Burwell, and his brother John (Fig. 1).

Another example concerned the manors of Kingston Wood, Kingston St. George, and Depdens, which John Crane bought in 1632 from the Chamberleyne family.⁵ They were left to his wife for her lifetime and would then pass "to my loveing cosen Mr Will Crane of Woodrising⁶ [the Fellow of Trinity College], sonne of John Crane of Loughton, Clerke Controller of his late Majestie's House⁷ . . . and after his decease to the use of Francis Crane⁸ his sonne and heire apparent, my godson, and his heires . . . and for the want of such issue to the use of my cozen Robert Crane gent. now or late one of the Fellowes of Trinity College^{9, 10} and brother of the said Will Crane of Woodrising." (Fig. 1).

It will be evident from the family bequests alone that the amount of land and property which John Crane possessed was very large indeed and, in addition, there were the bequests to the University and numerous friends and the provisions for Crane's Charities for the poor, sick scholars and the four towns. The executors of Crane's will were his cousin John Crane of Loughton and Thomas Rant¹¹ of Gray's Inn; each received £250 and deserved every penny. In a second codicil of 21 April 1652, five weeks before he died, Crane left £20 "to my deare and loveing friend Thomas Sclater,¹² Dr of Physicke and desire him to be an assistant to my executors in seeing my last will and testament performed."

⁴ W. W. Rouse Ball and J. A. Venn, *Admissions to Trinity College Cambridge*, 5 vols., London, Macmillan, 1913, vol. 2, p. 177. See also *Dictionary of national biography*.

⁵ D. Lysons and S. Lysons, *Magna Britannia, being a precise topographical account of the several counties of Great Britain*, 3 vols., London, printed for T. Cadell and W. Davies in the Strand, 1808, vol. 2, pt. 1, p. 223.

⁶ Rouse Ball and Venn, *op. cit.*, note 4 above, vol. 2, p. 316.

⁷ G. F. Russell Barker and A. H. Stenning, *The record of old Westminsters*, 3 vols., London, Chiswick Press, 1928, vol. 1, p. 229.

⁸ Rouse Ball and Venn, *op. cit.*, note 4 above, vol. 2, p. 435.

⁹ *Ibid.*, vol. 2, p. 229.

¹⁰ Russell Barker and Stenning, *op. cit.*, note 7 above, vol. 1, p. 229.

¹¹ J. Venn, *Biographical history of Gonville and Caius College*, 8 vols., Cambridge University Press, 1897, vol. 1 (1349–1713), p. 245.

¹² J. Venn and J. A. Venn, *Alumni Cantabrigienses*, 6 vols., Cambridge University Press, 1927, vol. 4, pt. 2, p. 88.

It is not known when John Crane came to Cambridge; the first information about his early life being his marriage at the age of thirty to Elizabeth Scarlett on 30 September 1601 at Great St. Mary's Church. She was the daughter of Peter Scarlett, an apothecary to whom Crane may have been an assistant or partner. He certainly shared the Scarletts' family house from 1607 until 1619 with William Scarlett,¹³ the brother of Peter who died in 1613. The house was adjacent to the west end of Great St. Mary's Church, where a John Scarlett came from Leominster in 1550 and set up in business as a stationer and bookbinder.¹⁴ It is now the site of No. 1 Trinity Street where there has been an unbroken succession of booksellers ever since. Crane and his wife had no children and in 1619 they moved a short distance to a house on the south side of Regent Walk (now Senate House Passage), where the Senate House now stands.

Crane's success as an apothecary was undoubtedly promoted by the patronage of "Dr." William Butler (1535–1618). Fuller¹⁵ records that Crane was "bred an apothecary in Cambridge, so diligent a youth that some judicious persons prognosticated that he would be a rich man. Dr. Butler took so great a fancy to him that he lived and died in his family, yea and left the main body of his rich estate unto him." The statement that Butler "lived and died" in Crane's family has been much quoted and is, at the least, misleading. The house in Regent Walk which Crane bought on 7 November 1617 was then "in the tenure and occupation of the famous and learned Gentleman Mr William Butler, Practitioner in Physicke", according to the conveyance.¹⁶ Also, in 1599 a previous deed of settlement by Simon Watson of Covington on his son Simon, specified that the house "had been of late in the tenure use and occupation of one Willyam Butler doctor in physicke and of one William Bettson."¹⁷ These deeds show conclusively that Butler had lived in the house for at least eighteen years before it became John Crane's property, and he died within three months after the purchase. Moreover, it is highly unlikely that the Cranes moved into the house during Butler's lifetime as they paid the parish rate for the Scarletts' house until the end of 1619, and in 1620–21 it was paid by Henry Moody.¹⁸ Nevertheless, John Crane was evidently both beholden and devoted to Butler, an eccentric character who never took the Cambridge M.D. degree but, having been an M.A. for six years, was granted the University Licence to practise medicine (L.M.) in 1572. He acquired a great reputation and numbered James I and Henry, Prince of Wales, among his patients. Butler left his estate of about £700 to Crane, who proved the will before the Vice-Chancellor's

¹³ J. Gray and W. M. Palmer, *Abstracts from the wills and testamentary documents of printers, binders and stationers of Cambridge from 1504 to 1699*, London, printed for The Bibliographic Society by Blades, East & Blades, 1915, p. 81.

¹⁴ Sir John Gray, 'King's College School in 1564', *Proc. Camb. Antiquarian Soc.*, 1964, **56–57**: 88–102.

¹⁵ T. Fuller, *The history of the worthies of England*, London, printed for F.G.W.L. and W.G., 1662, p. 160. J. Boss, 'William Butler (1535–1618): further evidence on a physician between two ages', *Med. Hist.*, 1977, **21**: 434–445. V. Nutton, 'Dr. Butler revisited', *ibid.*, **22**: 417–430.

¹⁶ CUA, D. VII. 2.

¹⁷ CUA, D. VII. 1.

¹⁸ Gray and Palmer, *op. cit.*, note 13 above, p. 93.

Court¹⁹ and also paid for the memorial to Butler in Great St. Mary's Church. This can still be seen with some difficulty, having been moved from its original position on the south side of the chancel to its present site high up on the north side. The monument was restored in 1904 by Clare College, of which Butler had been a Fellow and benefactor.

Unfortunately no records of Crane's apprenticeship survive and very few of his work as an apothecary. Nor is it known when he was, presumably, granted a licence by the University to practise as an apothecary. They were not entitled to practise medicine and came under the jurisdiction of the Vice-Chancellor as scholars' servants, for which they received certain privileges. Nevertheless, the apothecaries were much sought after in Cambridge in the early seventeenth century. In 1635 Dr. Ralph Winterton (Regius Professor of Physic in 1600–1636) wrote²⁰ to Dr. Simeon Fox, President of the Royal College of Physicians, protesting that there was no proper examination of those applying for the University licence to practise physic and asking for support in making one compulsory. The result, he said, was that physicians were undervalued in Cambridge and that "chirurgeons and apothecaries are sought unto, and physicians seldome but in a desperate case are consulted with, when a patient is ready to dye, and in this kind we have too many examples." One of these may well have been that of Edward Hyde, later the Earl of Clarendon,²¹ who was taken ill with smallpox in Cambridge in July 1628. He was attended by John Crane whom he described as "an eminent apothecary who had been bred up under Dr Butler and was in much greater practice than any physician in the University." Of himself he wrote, "It pleased God to preserve him from that devouring disease which was spread over him very furiously and had so prevailed over him that both his friends and physicians consulted of nothing but the place and manner of his burial."

A bill from John Crane survives in Christ's College, Cambridge, among the papers of Dr. Bainbridge, the Master, who died in 1646. It is difficult to decipher but is a list of remedies supplied from time to time and includes "a comfortable electuary", "a Dose of pylls", and "a coulying julip". The upper part for the Master is cancelled and receipted "payd and quitt John Crane." (Fig. 4).

Crane had close links with the University and friends among the exclusive circle of heads of houses and professors. It is highly probable that he was the John Crane who received the degree of M.A. on 7 March 1615 when James I and Charles, Prince of Wales, visited Cambridge.²² It is not surprising, therefore, that the University should have received bequests in his will. The charity for poor, sick scholars is mentioned

¹⁹ W. M. Palmer, 'Cambridgeshire doctors in the olden times', *Proc. Camb. Antiquarian Soc.*, 1910–11, new series, 9: 200–279, see pp. 248–250.

²⁰ C. Goodall, *The royal college of physicians of London founded and established by law and an historical account of the college's proceedings against empirics and unlicensed practisers in every prince's reign from their first incorporation to the murder of the royal martyr King Charles I*, London, printed by M. Flesher for Walter Kettilby at the Bishop's Head, in St. Paul's Churchyard, 1684, pp. 443–445.

²¹ E. Clarendon, *The life of Edward Earl of Clarendon, Lord High Chancellor of England and Chancellor of Oxford University, containing 1. an account of the Chancellor's life from his birth to the Restoration in 1660, 2. A continuation of the same and of his banishment in 1667. Written by himself*, Oxford, at the Clarendon Printing House, 1759, pp. 5, 6.

²² J. Venn and J. A. Venn, *op. cit.*, note 12 above, vol. 1, pt. 1, p. 413.

below but, in addition to this well-known benefaction, the University received two others. One was his house in Regent Walk after the death of his wife, who occupied it until 1661. It was to be used by the “Physick Professor to live in or lett for so long as he holds the Professor’s place . . . and after his decease or giving over his place to the next professor in physique all the same freely. And so to succeed . . . for ever. This I doe for that I have known som Physick Professors to wante houses to dwell in but have been putt to dwell in meane houses.” In 1723, however, the University wished to build the Senate House and this entailed demolition of the houses on the south side of Regent Walk. Crane’s house was therefore exchanged for one in Shoemaker’s Row (now Market Street). In 1919 the property was sold by the University to Messrs. W. Eaden Lilley and it is now incorporated into their department store. It is certain that none of the Physic Professors ever lived in either the Regent Walk or the Shoemaker’s Row house, but the rents formed part of their stipends as does the income today from the invested proceeds of the sale in 1919.

The other bequest to the University was fifty pounds apiece “to be lent freely to two honest men for them to be better enabled to buy provisions of sea fische or fowle the better to serve the Universitie and Towne . . .”, as he had observed much sickness occasioned by unwholesome food of that kind.

Crane also left personal legacies in his will to friends who were prominent figures in the University. Thus to Francis Glisson, the Regius Professor of Physic in 1636–77, he left a ring at forty shillings and another at £5 to Thomas Comber D.D., the ejected Master of Trinity College and husband of his niece, Susan. Crane also left £100 each to two bishops, Matthew Wren of Ely and Ralph Brownrig of Exeter, both strong royalists who had incurred serious trouble. Wren was Master of Peterhouse in 1634 before becoming Bishop of Ely in 1638. He headed royalist agitation in the Isle of Ely, was impeached in 1641, and imprisoned in the Tower until 1659. Ralph Brownrig who, like Crane’s father, was born in Ipswich, was Master of Catherine Hall before becoming Bishop of Exeter in 1641. He unwisely preached a royalist sermon before the University in 1645 and was deprived of his Mastership and See. Crane himself was a staunch royalist and not a man to forget his friends; as Fuller²³ put it – “Besides his concealed charities his hand was always open to all distressed royalists.” It is remarkable that he escaped trouble himself, but his relatives were not so fortunate. His cousin and executor John Crane of Loughton was sequestered from his appointment as Victualler to the Navy in 1643 when he accompanied Charles I to Oxford as Clerk Comptroller of his Household, and his son Robert Crane (p. 433), a Fellow of Trinity College, was ejected from his fellowship in 1645 until restored in 1660. John Crane’s cousin, Sir Richard Crane, who was a Captain and Gentleman of the Privy Chamber, was wounded at the siege of Bristol in 1645²⁴ and died shortly afterwards.

Cambridgeshire was predominantly royalist when Crane was High Sheriff in 1641. In July 1642 the king asked the University for money and plate and the *House of Commons Journal* records on 15 July 1642 that “Whereas Mr Cromwell hath sent down arms into the County of Cambridge for the defence of that county; it is this day

²³ Fuller, *op. cit.*, note 15 above, p. 161.

²⁴ *Cal. State papers Dom.*, 1645–47, pp. 104, 105.

ordered that Sir Dudley North shall forthwith pay to Mr Cromwell one hundred pounds, which he hath received from Mr Crane, late High Sheriff of the County of Cambridge; which said hundred pounds the said Mr Crane had remaining in his hands for coat and conduct money." Sir Dudley North, one of the two members of parliament for Cambridgeshire, was a parliamentarian and the coat and conduct money was evidently collected by Crane for royalist troops during his year as High Sheriff.

Crane was also closely connected with Great St. Mary's Church. The Scarletts' house and his own home in Regent Walk were within a stone's throw; he was married there, buried there, and his memorial inscription can still be seen there. Although he was fined in 1613 for refusing to be a churchwarden, he appeared later to fill the role of elder statesman and adviser. He presented a folio Common Prayer book and two large silver flagons to the church in 1631²⁵ and, in his will, he left £20 for the use of the senior churchwarden for the time being. In 1722, however, the money was applied to the use of the parish. The Charity Memorandum Book records, "At that time the parish was at great expence in having the bells newcast and adding two new ones to them to make the peal Ten." In connexion with his charity for the Town of Cambridge, Crane left forty shillings for a memorial sermon to be preached at Great St. Mary's Church on the second Tuesday in October every fourth year, in which the Town's charity grant was made. The last such sermon appears to have been delivered in 1889.

A final excerpt from Crane's will shows his concern for country people whose lives in the fens, especially in the winters, must have been extremely arduous. The passage runs as follows:

Whereas I have heard great complaynt made by very many to have a Passage way between Somersham and Chatris, which hath been a great loss to the countrey and extreame trouble to the passingers. I give 200 pounds to have a passable Causey or another way made sufficiently for carts, horses, men and beasts to pass safely winter and somer. If not done within five years of my decease – otherwise they loose this gift. [The use of the term 'they' to denote faceless functionaries over 300 years ago is interesting, but Crane evidently got his way for, in a codicil of 20 September 1651 he revoked the gift of the causeway "as it hath been undertaken."]

From the contents of his will and the other fragments of evidence about John Crane, it is possible to assess his character and capability. First and foremost he was a shrewd businessman who amassed a considerable fortune, partly from buying property and land and partly from his apothecary's practice. His greatest asset in the latter must have been the general acceptance that he was William Butler's natural successor. He was a kind man, as shown by his charities described below which demonstrated his regard for the old and poor and his desire to help and encourage the young. He played his part in public affairs as High Sheriff of the County and his social status was high both in the Town and University. His right to assume the arms of the Suffolk Cranes is not recorded at the College of Arms, but this does not necessarily mean that he was not entitled to them. A man of his status was unlikely to have falsely assumed them and his description as "armiger" on his memorial implies public acceptance. He was a staunch royalist and a good friend to those who suffered by their support.

²⁵ C. H. Cooper, *Memorials of Cambridge*, 3 vols., Cambridge, Metcalf, 1860–1866, vol. 3, p. 303.

JOHN CRANE'S CHARITY LANDS

To provide revenue for his charities to the poor, sick scholars of Cambridge University and to the towns of Wisbech, Cambridge, King's Lynn, and Ipswich, Crane instructed his executors to buy good land which would bring in £60 a year. They duly bought 171 acres at Fleet and Holbeach in Lincolnshire, known as the Fleet estate or Crane's Charity Lands. It was vested in ten trustees of whom two were nominated by each of the five beneficiaries. The revenue from the rents was to be paid to each in turn in quinquennial cycles. In the first year it would go to Cambridge University for the poor, sick scholars and in the subsequent four years to the towns in the order mentioned above. But whereas the money received by the University was to be used only for the sick scholars, that for the four towns was for providing interest-free loans of £20, repayable after ten years, to young men setting up in trade. After each town had accumulated a fund or stock of £200 for the loans the use of the income would change and thereafter be used for the relief of honest men in prison for debt, old women, and poor men in want. In addition, forty shillings were added for each town to pay for a memorial sermon to be preached on the second Tuesday in October in the year when the income was received, "to commemorate the donor and to invite other men to do the like." Each town and the University had a body of local distributors, as laid down in Crane's will, who were to see that the money was spent according to his instructions. They also had to manage the Fleet estate during the one year in five in which their town or the University received the income. Thus they had to put the lands up for auction to the highest bidder for one year only, pay a one-fifth share of taxes and legal expenses of the Fleet estate, and collect the rents. As might be supposed, it was not long before the lack of any central control led to trouble. Several tenants failed to pay their rents and Ipswich suffered so badly in this respect that the town's stock of £200 for the loans to young men was not amassed until 1713, whereas it should have been completed by 1677 if the quinquennial income had, in fact, been £60 a year.²⁶ There was also the problem of the care and maintenance of the lands. This was raised in May 1746 by Henry Partridge, the Recorder of King's Lynn and a local distributor for that town. He wrote to the Vice-Chancellor of Cambridge University²⁷ emphasizing that putting the Fleet Estate up for auction for one year only meant that no tenant could depend upon having the lands for longer and, consequently, would do no more than take all that he could out of them. As a result the land was becoming progressively impoverished and would fall in value. He suggested that a good tenant should have a lease for a term of years under covenants to take proper care of the lands. This proposal was accepted by all the beneficiaries and the lands were let to Thomas Hather and his son John Hather for a term of twenty years from Lady Day 1747 at £66 a year payable half-yearly. Unhappily nothing was done about supervision of the tenants and within a few years the elder Hather died and his son defaulted on the rent and disappeared, having assigned the lease to someone else. In 1758 the Town Clerk of Ipswich urged the appointment of one man as a Receiver for the five

²⁶ R. Canning, *An account of the gifts and legacies that have been given and bequeathed to charitable uses in the town of Ipswich with some account of the present state and management and some proposals for the future regulation of them*, Ipswich, printed by W. Craighton, 1747, pp. 92–95.

²⁷ CUR. 122. 19. no. 1.

beneficiaries who would collect all the rents, and keep the tenants up to their half-yearly payments.²⁸ But it was not until 1807 that solicitors in Wisbech were appointed to act for the Trustees of Cranes' Charity Lands and arrange leases, collect rents, and supervise the tenants.

This was a step forward, but in 1850 it was discovered that, of the last body of Trustees appointed in 1788, only one was still alive. He was Sir William Fowle Fowle Middleton of Ipswich, who was then aged eighty-four. Under the terms of Crane's will, new trustees had to be appointed when their number fell to two and the University, with the towns of Cambridge, Wisbech, and King's Lynn, had submitted the names of new trustees and approved a draft deed of appointment. But the Town Clerk of Ipswich and the solicitors of Sir W. F. F. Middleton declined to do so on legal questions concerning the right to nominate trustees.²⁹ A legal wrangle ensued, with numerous inconclusive meetings of the interested parties, until 1858 when all except Ipswich applied to the Charity Commissioners for leave to request the Master of the Rolls for definite orders. On 25 November 1859 he ordered³⁰ that the sole surviving trustee should be discharged, that Crane's Charity Lands should be vested in the official Trustee of Charity Lands, and that a Receiver and Manager be appointed by the five beneficiaries to act under their control for arranging leases up to ten years, collecting rents, general management, and paying over one-fifth of net proceeds annually to each of the beneficiaries. He also confirmed the payment of forty shillings for a memorial service every fourth year in each of the four towns. The money paid to the Vice-Chancellor of Cambridge University would continue to be applied for the benefit of poor, sick scholars, but the uses of that paid to the four towns was varied.

Thus, at long last, the beneficiaries were relieved of all administrative responsibility after some 150 years. In 1951 the Charity Commissioners sold the Fleet Estate and invested the proceeds in 2½ per cent Treasury Stock dated "1975 or after". Each beneficiary was credited with a holding of £6,072 10s. 5d., which produced an annual income of £152 although the capital value has steadily diminished. In the four towns Crane's Charity money has been merged into municipal charitable funds and only in Cambridge University has his benefaction survived in its original form.

JOHN CRANE'S CHARITY FOR POOR, SICK SCHOLARS

In his will John Crane directed that Cambridge University should receive £60 every fifth year "to be given to poore schollars for their Reliefe when they are sicke for paying for their physick, dyet or other things necessary for them in their sickness, knowing heretofore many have miscarried for want of meanes to relieve them. This to be bestowed by the present Vice-Chancellor, the three professors of Divinity, Civil Law and Physick and the Chiefe Apothecary in the Towne for that he knows the need of most of the poore schollars in that case desiring the Master of Caius Colledg to joyne with them to assist them." The composition of the Board of Distributors has remained unchanged, except that the title of Chief Apothecary of the Town has, since

²⁸ CUR. 122. no. 20. (11).

²⁹ CUR. 122. no. 20. (34).

³⁰ CUR. 122. no. 20. (36).

1902, been assumed by a consultant physician or surgeon of Addenbrooke's Hospital. It is noteworthy that the revenue of the charity had risen from the original £60 every fifth year, first paid in 1659, to an annual income of some £1,500 in 1974 and in that year the capital reserves stood at about £8,000. The Charity Commissioners still pay £152 a year from the invested proceeds of the sale of the Fleet Estate in 1951 but the remainder of the income and the formation of a capital reserve has come from the investment of undistributed income over the years.

The first recorded grant to a poor scholar appears in "An abstract of receipts and disbursements on account of Mr Crane's Benefaction" in the University Audit Books for the years 3 November 1714 to 3 November 1754.³¹ The entry is brief: "1720. Dr. Gooch [Vice-Chancellor] To Mr. Popple [Tutor of Trinity College] for a scholar 10.10.0." It is followed by another at greater length of 13 April 1722:³² "We whose names are hereunto subscribed do approve of ye distribution of five guineas part of Mr Crane's Charity made by ye Vice-Chancellor to Gilbert Burnet, a poor scholar of Kathrine Hall that had been a long time sick. The same sum is likewise granted by us to Barnes, a scholar of Pembroke Hall that had been sick. Tho: Crosse Vice-Chancellor, Chris. Green Phys. Professor, Tho. Roper Sen^r Apothecary." Some more brief accounts survive for the period 1755 to 1767 during which grants were made to some sixty scholars, averaging about £5 each. As mentioned above (p. 439) the distributors were liable for a one-fifth share of the legal and other expenses of the Fleet Estate and the accounts are qualified by a sad little note from the auditor: "NB. £17 17s. 6d. in the year 1720 should have been paid by the five corporations but I cannot find that any of them paid the University their respective shares." These records make it perfectly clear that Crane's Charity functioned in the University from 1720 at the latest, although it is incorrectly stated in two places^{33,34} that "This part of Crane's benefaction remained inoperative until 1822 when public attention was called to the state of affairs." The source of this error is a confusion of Crane's Charity for poor scholars of the University with his Charity for the town of Cambridge. There was indeed a public outcry in 1822 at the town's neglect of its charity and Cambridge Corporation was severely criticized at a Charity Commissioner's enquiry in 1837.³⁵ The confusion evidently arose because the distributors for the Town's Charity, as laid down in Crane's will, were the same persons as those for the University Charity but with the addition of the Mayor, the Recorder, and three Aldermen. To make confusion worse confounded, the Vice-Chancellor of the University was the chairman of both distributing bodies and some of the letters of protest at the Town's neglect of its charity found their way into the University's archives.

Before the growth of the voluntary hospitals system in the early eighteenth century, the lot of poor, sick scholars in the University was very hard. If too ill to travel home, they could only stay in colleges or lodgings and hope to be tended by friends, bed-

³¹ CUR. 122. no. 18.

³² CUR. 122. no. 17.

³³ J. W. Clark, *Endowments of the University of Cambridge*, Cambridge University Press, 1904, p. 566.

³⁴ Sir H. D. Rolleston, *The Cambridge Medical School; a biographical history*, Cambridge University Press, 1932, p. 124.

³⁵ *Reports from Commissioners*, 1. Charities, XXIV, 1837–38, p. 16.

makers, or servants. Addenbrooke's Hospital did not open with ten beds until 13 October 1766 and was enlarged in 1813, but members of the University were not admitted except in dire emergency and private nursing homes were unknown. In 1845 the distributors of Crane's Charity notified college tutors that they were willing to apply to the Institute of Nursing Sisters in London for nurses to attend poor, sick scholars and to pay their wages. It is not known to what extent this enlightened offer was taken up, but in 1875 the Distributors supported the "Ladies Institute for Training Nurses" at no. 1 Bene't Place in Cambridge, a precursor of the Addenbrooke's Hospital Nurses Training School, with Grants of £50 a year until 1892. During the war of 1914–18, applications for grants from Crane's Charity fell to less than ten per annum and did not return to the pre-war level of twenty or more until 1920. From then until 1939 the income of the charity averaged about £400 a year and grants about £170. During the war years of 1939–45 applications for grants again fell sharply and totalled only twenty-one at a cost of £534. From 1946 until the inception of the National Health Service in 1948, applications for grants never reached the levels in 1920–39 and the future of Crane's Charity could not be confidently forecast. The provision of all medical treatment by the state might well abolish the need for it but, on the other hand, the special circumstances of undergraduate life were not those for which the National Health Service had been designed. Careers and examination results might be seriously prejudiced by illness which did not warrant immediate hospital treatment, but which would interfere with attendance at lectures or with private study. In such cases speedy treatment on a private basis might well be desirable. In addition, the recurrent changes of an undergraduate's residence between home and university might well prevent hospital admission at one or other place. The distributors were prepared to assist in such special circumstances provided that evidence of financial need was produced and adequate reasons were stated as to why the National Health Service facilities could not be used. In the event it became clear that, in the special circumstances of university life, there was still a justifiable demand for Crane's Charity, which continues to fulfil its founder's intentions after some three hundred years.³⁶

JOHN CRANE'S CHARITIES IN THE TOWNS OF WISBECH, CAMBRIDGE, KING'S LYNN, AND IPSWICH

The distributors of Crane's Charities in the four towns had the same difficulties with management of the Fleet Estate as did those of Cambridge University. In addition they had two different classes of recipients, namely young men setting up in trade and, after £200 had been accumulated for these, the income would go to honest men in prison for debt, old women, and poor men in want. The distributors were sternly enjoined in Crane's will that "as they will answer it before God, they relieve the most honest, godliest and religious men and women that had lived well and have fallen into

³⁶ A formal minute book recording the proceedings of meetings of the distributors of Crane's Charity in Cambridge University (CUA. Char. 11. Crane's Charity, vol. 1, 1822–1922) has been freely consulted but references are not indicated in the text as it contains confidential information about individuals. The second volume, commenced in November 1923, is still in use and is not yet listed in the archives.

John Crane (1571–1652)

decay by some extraordinary occasion, and not give it to dissembling and Hippocritical persons.” The attention paid to these instructions varied widely in the four towns because the local distributors were not supervised by the trustees nominated by their towns and were subject only to Crane’s instructions and their own consciences. The charities and the distributors’ responsibilities effectively ceased in 1859, as directed by the Master of the Rolls (p. 440) and the identity of John Crane, as the donor of the money which became merged in municipal charitable funds, vanished. With the sale of the Fleet Estate by the Charity Commissioners in 1951, the final link was broken.

Wisbech

John Crane had a special affection for Wisbech as his birthplace, and the bequests to his relatives of land and property in the vicinity suggests that they lived there. In addition to his main Charity he also left the town £100 towards building a town hall, and a house or inn named the Black Bull on the Market Hill. This, with its associated oil mills, barns, and stables was estimated by Crane as being worth £40 a year or more. One half of this suggested rent was to be added to the wages of the schoolmaster of the free school each year and the other half to be spent on corn and firing for the poor at Christmas or New Year’s day. The property was sold by the Burgesses in 1802 under the name of the Three Tuns and part of the proceeds was used for redemption of Land Tax on the general estates of the Corporation. This they had no right to do and were reprimanded by the Charity Commissioners who, in their report of 1837–38,³⁷ also considered that the schoolmaster might well be entitled to half of the improved income resulting from the sale, instead of £20 as estimated by Crane. The main charity for setting up young men in trade was fully utilized and in 1898 no loans were outstanding. But the subsequent income for relief of the poor had been somewhat lavishly distributed and, in 1822, the Reverend Jeremiah Jackson³⁸ was uneasy about the large numbers of up to 400 persons receiving Crane’s Charity in some years. He wrote³⁹ “It would seem to imply that the poor of Wisbech are equally distinguished by their virtues or that the wise and solemn directions of the Founder are not properly attended to . . .”. However, in 1859 the Master of the Rolls ordered that the income from the Fleet Estate should be paid annually to the Treasurer of the Municipal Charity Trustees and in November 1965 all the Wisbech charities were united under a scheme approved by the Charity Commissioners entitled Wisbech Charities.⁴⁰

Cambridge

The story of the management of Crane’s Charity in the town of Cambridge is far from creditable. Although the first payment of rents from the Fleet Estate was made in 1661 no accounts were kept and no meetings of the distributors recorded before

³⁷ *Reports from Commissioners*, op. cit., note 35 above, p. 279.

³⁸ J. Venn and J. A. Venn, op. cit., note 12 above, vol. 3, pt. 2, p. 537.

³⁹ Jeremiah Jackson, *Some account of the principal public charities of Wisbech St. Peter, to which are prefixed considerations on public charities in general*, Wisbech, 1822, pp. 24–33, 100.

⁴⁰ J. S. Beall, ‘Wisbech Charities’, *The Wisbech Society and Preservation Trust Ltd.*, 32nd annual report, 1971, p. 14–17.

1822. In their report of 1837–38⁴¹ the Charity Commissioners stated that “The Charity has been greatly abused by the late Corporation of Cambridge [then a Borough], only 27 loans [for setting up young men in trade] have been made from the year 1701 to 30 December 1817 inclusive.” Only after a public outcry at the neglect of the town’s Charity did the distributors meet in 1822. The University members of the body (p. 441), led by the Bishop of Bristol, then the Regius Professor of Divinity, immediately entered a formal protest affirming their ignorance of having been nominated by John Crane as distributors of his Charity for the Town of Cambridge as well as for the University. Moreover, members of the Corporation called to the Charity Commissioners’ enquiry denied any knowledge of the Charity for the Town. But the Commissioners “had no doubt that the professed ignorance [of the Corporation] could scarcely have been universal and that some members must have been wilfully guilty of this flagrant violation of the trust reposed in them.” However, after the outcry in 1822 the Charity was hastily put in order, so far as it was possible, and the Distributors met half-yearly until 1859 when the Master of the Rolls ordered variations in the use of the Charity income. The income was to be paid to the Treasurer of the Borough of Cambridge annually and be applied “for the benefit of such hospital or hospitals or other institutions of a charitable nature within the Borough or some parish contiguous.”⁴² The loans for young men were not affected although, in 1882, leave was given for making smaller loans and the unused capital stock could be invested and the income be applied to the cost of outfits for men entering trade, occupation, or service. Finally, in November 1898 the Charity Commissioners, in consultation with the local authorities, diverted all the income of Crane’s Charity to educational purposes in the Borough and County of Cambridge.⁴³ It was suggested (a) that Crane prizes should be maintained at the Technical Institute, which would open in September 1900, in respect of agriculture, horticulture, building, or other subjects pursued; and (b) that a Crane exhibition should be tenable by a boy in the commercial department of the Perse School at Cambridge. It has not been possible to ascertain whether either of these projects was carried out, but there is certainly no mention of (b) in the history of the Perse School,⁴⁴ and there are no Crane prizes in the present Cambridgeshire College of Arts and Technology. Crane’s name and charity have thus vanished from the City of Cambridge.

King’s Lynn

According to John Crane’s will the fourth year’s revenue in each quinquennial cycle was to go “to the Towne Corporate of King’s Lynn in Norfolk, there to be lent to three young men in the like order as Wisbech and Cambridge doth; this to be lent by the Mayor of King’s Lynn for the time being, the Recorder and foure of the Cheife Aldermen, the revenue being twenty pounds a man.” The first payment of Fleet Estate

⁴¹ *Reports from Commissioners*, op. cit., note 35 above, p. 16.

⁴² CUR. 122. 34. no. 36.

⁴³ *Borough of Cambridge education committee minute book*, 1891–1901. See meetings 17 August 1898 and 30 November 1898.

⁴⁴ J. M. Gray, *A history of the Perse school, Cambridge*, Cambridge, Bowes & Bowes, 1921.

rents was made in 1662. The interest-free loans to three young men had been fully used when the Charity Commissioners reported in 1834.⁴⁵ The stock of £200 for loans had been reduced to £160 by the death and insolvency of two borrowers and their sureties. Distribution of the income to the poor was made by dividing it into five equal parts delivered to the Mayor and four senior aldermen or, if the Recorder were present, into six parts. These were distributed amongst such poor persons of the town as each party might select in sums varying from 10s. to £2. A book of accounts was kept. The Crane commemorative sermons were preached in St. Margaret's Church. The Commissioners commented that "the trustees nominated by the town never met or took any part in the management of the Fleet Estate." In 1859, upon the reorganization of the charity by the Master of the Rolls, the use of the quinquennial income was changed. It was to be paid annually, and one shilling a week was to be paid to each of the occupants of three almshouses in the Borough, namely St. James', Smith's, and Valinger's, in augmentation of their stipends. The money later became merged with that of the Municipal Charity Trustees.

Ipswich

John Crane's Charity for Ipswich was evidently an act of filial piety. His will states that "The fifth year's revenues I give to the towne corporate of Ipswich where Mr Butler of famous memory was borne, and so my own Father . . . thus to be disposed and lent by two Bailiffs of Ipswich, the Recorder and foure of the Chiefe men in that body, they taking good securitie for every twenty pounds soe lent in like order as Wisbeech doth . . .". The first payment of rents from the Fleet Estate was received in 1663 but the amounts were very variable in the early years and less than £60, so that the stock of £200 for loans to young men was not accumulated until 1713 (p. 439). A report of the Charity Commissioners in 1828⁴⁶ commented upon this trouble but gave the amount of rent received from leases expiring in 1807 as £139 15s. 0d. and as £395 10s. 0d. for those expiring in 1827, so the Fleet Estate had evidently recovered. The Commissioners also noted that since 1713 the distributors had made loans to young men according to Crane's instructions and had entered them in an audit book. But the disposal of the income designated for the poor was quite obscure. The Account of Ipswich Charities of 1747⁴⁷ states that Ipswich had received the rents six times in the previous thirty years but that no accounts existed except for one year when the money was not disposed of according to Crane's will. The Commissioners also recorded that there were no accounts for the year 1823 and they had found that the late Town Clerk, who had since become bankrupt, had retained the balance and stated before the Commissioners of Bankruptcy that some £200 was due to the Charity. In 1859 the Master of the Rolls ordered that the rents of the Fleet Estate were to be paid annually to the Treasurer of the Municipal Charities Trustees and he also directed that Crane's commemoration sermon should be preached in St. Matthew's Church, on the second Tuesday in October. It had been regularly preached from 1743 until 1819 or later, but not within present living memory.

⁴⁵ *Reports from Commissioners for inquiring into certain charities*, 1834, no. 28, vol. XXII, p. 49.

⁴⁶ *Reports from Commissioners. Charities*, 1828, vol. XI, p. 473.

⁴⁷ Canning, *op. cit.*, note 26 above, pp. 92–95.

SUMMARY

John Crane, the apothecary and philanthropist, was born in Wisbech and lived in Cambridge for most of his life. He came under the patronage of "Dr." William Butler (1535–1618), an eccentric Fellow of Clare College who practised medicine under the University Licence (M.L.), and numbered James I and Henry, Prince of Wales, among his patients. After Butler's death Crane was regarded as his natural successor and became a wealthy man. Nothing is known of Crane's parents and near relatives beyond the names of the latter in his will, and very little about his professional practice. He was evidently a shrewd businessman, and played his part in local affairs as High Sheriff of Cambridgeshire in 1641. His name is mainly remembered for his charities left to Cambridge University, for the benefit of poor, sick scholars, and to the towns of Wisbech, Cambridge, King's Lynn, and Ipswich for setting up young men in trade and relieving the old and poor. Brief accounts of the charities are given but only that for the poor, sick scholars survives today.