

“Nanobalance” Based on Carbon Nanotubes Shows New Application for Nanomechanics

A “nanobalance” small enough to weigh viruses and other submicron-scale particles is one application for newly discovered electronic and micromechanical properties of carbon nanotubes. A report in the March 5 issue of *Science* describes how electrical voltage can be used to induce electrostatic deflection and vibrational resonance in individual carbon nanotubes. This ability to selectively deflect or induce resonance in individual nanotubes opens opportunities in micromechanical applications of carbon nanotubes.

Researchers at the Georgia Institute of Technology studied the behavior of multi-walled nanotubes using a transmission electron microscope with a sample holder that allowed them to rotate specimens, apply electrical voltage, and observe many fundamental effects. The researchers created resonance in the nanotubes by applying an oscillating voltage. By carefully tuning the oscillation frequency, they were able to

induce resonant vibration in nanotubes. Each nanotube resonates at a specific frequency that depends on its length, diameter, density, and elastic properties. Philippe Poncharal of Georgia Tech said, “You can select which one you want to examine and make it resonate. Then you turn up the frequency and another one will resonate.”

Z.L. Wang, professor in Georgia Tech’s School of Materials Science and Engineering, said, “We can bend a nanotube almost 90 degrees, and it will still recover and straighten out. You can keep on bending them and they will not break. This shows that although nanotubes are very rigid, they have an extremely high elastic limit. Very few materials can do this without damage.”

Walter de Heer, professor in Georgia Tech’s School of Physics, said, “One of the most important characteristics of nanotubes is that they are extremely rigid and strong. That’s true when they are very thin. But we have found that as you start making them thicker, their elastic proper-

ties become weaker, and they become softer. They enter a new mode of bending.”

Using high-resolution transmission electron microscopy, Daniel Ugarte of the Laboratorio Nacional de Luz Sincrotron in Brazil observed a rippling on the surface of thick nanotubes as they deflected. This confirms that bending in these tubes is different.

Wang said, “The elastic constant is varying as a function of its diameter, which is unexpected for a general material. This elastic constant should be an intrinsic property of the tubes, rather than depending on its geometry or size.”

Using the tiny tubes as a “nanobalance” depends on the ability to calculate changes in the resonant frequency that occurs with placement of an object onto a nanotube. De Heer said, “By knowing the properties of the spring, you can measure the mass of the object. We can use the nanotube like a standard calibrated spring.”

Applying this technique, the researchers were able to measure the mass of a 22 femtogram graphite particle attached to the end of a resonating nanotube.

Standard Vacuum Components For All Applications

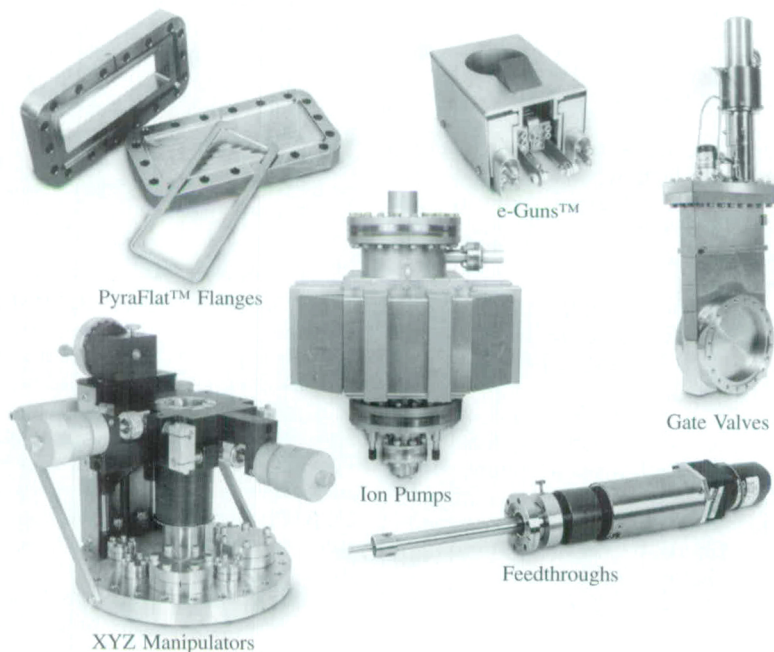

Thermionics offers a full line of vacuum components from ion pumps to xyz manipulators. What sets us apart from other companies is our ability to listen to and understand your specific vacuum requirements.

Whether you need a thermocouple gauge tube or a complete system, our engineers will ensure that you get exactly what you need.

For your free copy of our 340-page catalog, contact:

thermionics
vacuum products

231-B Otto Street
Port Townsend, WA 98368
Toll-free: (800) 962-2310 ext. 143
Fax: (360) 385-6617
Internet: www.thermionics.com
Email: sales@thermionics.com

Circle No. 10 on Reader Service Card.

Engineered Glass Tempering Halts Cracks

A problem with chemical and heat-tempered glasses is that, while they withstand more stress before breaking than untreated glass, when they break, they do so catastrophically. Another problem is that, while each individual piece of glass becomes stronger, the variability of strength between pieces of glass increases dramatically. Engineers choosing glass for specific purposes must account for this wider range of strengths. David J. Green, a professor of ceramic science and engineering at The Pennsylvania State University, working with R. Tandon of Caterpillar Inc., in Peoria, Illinois, and V.M. Sglavo of the University of Trento,

Italy, developed a theoretical approach to designing strengthened glass. Conventional tempering of glass alters the outer surface of the glass so that it is under compression. Glass under compression can withstand higher levels of stress before reaching the failure point.

"Rather than simply altering the outside layer of glass, we would like to engineer the glass so that it has a specific compression profile making the final product stronger and less variable," said Green.

As reported in the February 26 issue of *Science*, the researchers tested their theory using the chemical tempering process on sodium aluminosilicate glass, but believe that they could adapt the process to other tempering processes and other materials.

In chemical tempering, potassium atoms are often used to replace some of the sodium atoms near the surface. These potassium atoms are slightly larger than the sodium atoms and they compress the layer in which they are substituted by crowding the other atoms. Chemical tempering usually occurs in the outer millimeter of the pane of glass.

Green said, "If we place the maximum compression layer beneath the surface, when cracks propagate from the flaws on the surface, they reach the layer and stop."

The researchers created these internal compressed layers by subjecting the glass to chemical processing where potassium substituted for sodium, but then exchanged some of the potassium near the surface back to sodium. This created glass with an untempered surface, but with a tempered, compressed layer below.

"Unexpectedly, glass made in this way exhibits multiple cracking," said Green. "Unlike untreated glass or conventionally tempered glass where a crack that begins progresses rapidly to catastrophic failure, small cracks begin to form in the untempered layer and then the cracks are arrested by the compressed layer."

Many cracks may form before the ultimate crack that propagates through the compressed layer and shatters the glass. This surface crazing can be used as a warning that the glass is approaching its breaking point and needs to be replaced. Creating glass that will only break at a certain, predetermined stress level may also be possible.

"The strength range of a batch of conventionally tempered glass may be as broad as 25% on either side of the average strength," Green said. "However, the specially designed glass we are looking at has a range of only 6 percent on either side of the average." This smaller range provides more consistency when manufacturing the glass.

"Nanobubblepack" with 10–100 nm Pores Fabricated

Chemists at The Pennsylvania State University have discovered a class of porous materials with an orderly crystal-like arrangement of ultrasmall spherical spaces. The researchers reported in the February 12 issue of *Science* that they can produce the material in a range of pore sizes between 10 and 100 nm, opening the door to a variety of potential uses in industry and research.

Thomas Mallouk, professor of chemistry at Penn State and principal author of the paper describing the research, said that then-graduate students Stacy A. Johnson and Patricia J. Ollivier—now



Glenn Theodore Seaborg, Nobel Laureate chemist, died February 25. He was the discoverer of 10 atomic elements including plutonium and one that now bears his name, Associate Director-at-Large of the Lawrence Berkeley National Laboratory, University Professor of Chemistry for the University of California, and co-founder and chair of the Lawrence Hall of Science.

Seaborg is best known for his role in the discovery of plutonium. This took place in 1940, when Seaborg, Edwin McMillan, Joseph Kennedy, and Arthur Wahl, using the 60-inch cyclotron built by Ernest Lawrence, bombarded a sample of uranium with deuterons and transmuted it into plutonium. In 1944, Seaborg formulated the "actinide concept" of heavy element electronic structure that predicted that the actinides—including the first 11 transuranium elements—would form a transition series analogous to the rare earth series of lanthanide elements. Called one of the most significant changes in the periodic table since Mendeleev's 19th century design, the actinide concept showed how the transuranium elements fit into the periodic table. Seaborg and his colleagues used this concept as a stepping stone to the creation of a succession of transuranium elements, including americium, curium, berkelium, californium, einsteinium, fermium, mendelevium, nobelium, and seaborgium.

Throughout his research career, Seaborg was also a champion for science education. In addition to his role in establishing the Lawrence Hall of Science, he was a member of President Reagan's National Commission on Excellence in Education, which produced the landmark 1983 report, "A Nation at Risk: The Imperative for Educational Reform." He was also a primary mover behind "Great Explorations in Math and Science," a leading Internet resource for science teachers.

Seaborg was a major advocate for nuclear arms control, international cooperation in science, and conservation of natural resources. He served as chair of the Atomic Energy Commission (the predecessor to the U.S. Department of Energy) under Presidents Kennedy, Johnson, and Nixon (1961–1971).

In addition to sharing the 1951 Nobel Prize in Chemistry with McMillan for research into the transuranium elements, Seaborg received the National Medal of Science in 1991, the United States' highest award for scientific achievement. He was a member of the Manhattan Project, chancellor of the University of California at Berkeley (1958–1961), and he also served as president for both the American Association for the Advancement of Science and the American Chemical Society.

He wrote more than 500 scientific articles and numerous books including an autobiography soon to be published entitled, *A Chemist in the White House: From the Manhattan Project to the End of the Cold War*. He held more than 40 patents, including the only ones for a chemical element (americium and curium), and had been awarded more than 50 honorary doctoral degrees.

both at DuPont—initially proposed the idea for making the material. Mallouk said that they wanted to make “organic porous materials using uniform inorganic materials as a template, and make uniform pores in the size range between 10 and 100 nm.”

While researchers have been able to fabricate pores larger than 100 nm, using polymer spheres as templates, and pores smaller than 10 nm by using small molecules or groups of molecules as templates, making pores between 10-100 nm has eluded them for lack of suitable templates in that size range. Johnson and Ollivier borrowed a technique for making identical spheres of silica (35 nm in diameter). They first filled a pellet press with the 35-nm silica spheres, then pressed and heated them to form a colloidal-crystal pellet in which all the silica spheres were closely packed in an orderly arrangement. The researchers then used this pellet as a mold, saturating the spaces between the spheres with a liquid monomer. They processed the pellet to transform the liquid monomer into a solid polymer and

chemically dissolved the silica spheres. Mallouk said, “What you get is 75% empty space made up of identical spherical chambers surrounded by an organic polymer—the same shape and orderly arrangement as the silica spheres you started with. It’s something like nanobubblepack except that the chambers are connected by channels, which makes this material particularly porous.”

Johnson and Ollivier next tried making the material with different mixtures of one monomer, ethyleneglycol dimethacrylate (EDMA), that has a tendency to shrink and another monomer, divinylbenzene (DVB), that does not. Mallouk said, “When you use EDMA alone, it shrinks by a factor of about 2.5 as soon as you etch the silica spheres away, so if you start with 35-nm spheres you know you’re going to get 15-nm pores. We can get a range of uniform pore sizes, anywhere between 15 and 35 nm, just by varying the mixture of EDMA and DVB.”

The researchers said they can dial in a specific pore size anywhere they want in the previously untouched size range.

Mallouk said, “Magnetism, ferroelectricity in semiconductors, and certain optical properties disappear in a material if you break it into small enough pieces.” He said that particles made in precise sizes in the pores of this new material could be useful to researchers trying to understand how the fundamental physics of such properties changes with decreasing size and to learn exactly when molecular-scale properties start to take over.

Supersonic Deformation of Materials Predicted

Scientists from the Max-Planck-Institute of Metals Research in Stuttgart and Stanford University have predicted that deformation can be passed through materials faster than the speed of sound. As reported in the February 12 issue of *Science*, this finding is very surprising since the sound velocity has so far been considered the upper limit for the velocity of all mechanical processes including deformation. Atomistic simulations have shown that this is not the case, and that a stress concentrator like a crack tip or a

New!
MDC 1999 Catalog

- Flanges & Fittings
- Valves
- Roughing Components
- Vacuum Measurement
- Viewports & Glass Components
- Electrical & Fluid Feedthroughs
- Motion & Manipulation
- Thin Film Deposition
- Chambers
- Custom Engineering

Request your copy today!

MDC
VACUUM PRODUCTS CORPORATION

Building-Blocks
for Vacuum Science and Technology

The building-blocks for vacuum science and technology...

This 544 page catalog details MDC's expanded line of high and ultrahigh vacuum components. From basic elastomer gaskets to sophisticated instruments for e-beam evaporation, MDC provides dependable and reliable solutions for vacuum science and technology. New products featured include multipin Type-D subminiature feedthroughs, thin-wall stainless steel flex hose, glass viewports, in-vacuum BNC cable and connector assemblies, UHV stepper motors and CE certified power supplies. MDC is committed to providing products and services that set the industry standard for customer satisfaction in quality, delivery and cost performance.

...from one source dedicated to quality and service.

MDC Vacuum Products Corporation
23842 Cabot Boulevard Hayward, CA 94545

Phone	510-265-3500
Toll-Free	800-443-8817
Fax	510-887-0626
e-mail	sales@mdc-vacuum.com
Web	mdc-vacuum.com

Circle No. 7 on Reader Service Card.

sharp indenter may induce deformation at supersonic velocities.

The irreversible plastic deformation of crystalline materials like metals or semiconductor crystals is mainly carried by the motion of dislocations, which are line defects of the crystal lattice. The velocity of these dislocations is limited by lattice friction and by drag effects from the interaction with lattice vibrations and electrons. At low temperatures and high stresses, dislocation velocities can reach sizeable fractions of the shear wave speed.

Using atomistic computer simulations, the researchers have discovered that accelerating a subsonic dislocation through the sound barrier is not necessary, but that the dislocation can be "born" as a supersonic dislocation. This requires a strong stress concentration such as provided by a crack tip or a sharp indenter. Once the supersonic dislocations are generated, the researchers can easily study the properties. The scientists have found that sustained supersonic motion is possible in an elastically loaded body. Even the sound barrier at the shear wave velocity has been investigated by decelerating the superson-

ic dislocation until it drops through the sound barrier. During this process, the dislocation stops completely before it restarts again as a subsonic dislocation. (This process can be viewed as an animated sequence of images at website <http://finix.mpi-stuttgart.mpg.de/~gumbsch/warp.html>). According to the researchers, while this temporary stopping can be reconciled with continuum elasticity theory, many of the properties of the supersonic dislocations, like their nucleation and radiation, cannot be reconciled and are clearly connected to the nonlinear nature of the atomic interaction.

"Bucky Shuttle" Projected as Possible Computer Memory Element

In current computer design in which an uncharged capacitor is a binary "0" and a charged capacitor denotes a "1," the capacitors tend to leak and need to be regularly "topped off," which requires extra power. Through computer simulation, physicist David Tomanek of Michigan State University designed a "bucky shuttle" in which tiny carbon spheres trapped in equally small tubes can be used for fast, low-power storage of computer data.

As reported in the February 15 issue of *Physical Review Letters*, Tomanek thought of using an electric field to move a buckyball within a nanotube from one end to the other within the tube, storing a zero or a one. Tomanek and physicist Sumio Iijima of NEC Research Laboratories in Japan ran computer simulations to test the idea. The bucky shuttle should be about 10 times faster than conventional memory, they concluded—switching from a "0" to a "1" in 4 picoseconds. The shuttle was durable as well. Once moved, the buckyball stayed put. Tomanek anticipates that, by lining up multiple shuttles and wiring them into a matrix, it would be possible in the future to build a storage device.

NAE Elects Members and Foreign Associates

The National Academy of Engineering (NAE) has elected 80 engineers and eight foreign associates to membership in the Academy, bringing the Academy's total U.S. membership to 1,984 and the number of foreign associates to 154. Election to the National Academy of Engineering is among the highest professional distinctions accorded an engineer. Academy membership honors those who have made "important contributions to engineering theory and practice, including significant contributions to the literature of engineering theory and practice," and

those who have demonstrated "unusual accomplishment in the pioneering of new and developing fields of technology."

Among the new members are **Mark G. Benz**, metallurgist, General Electric Corporate Research and Development, Niskayuna, N.Y., for contributions to nuclear fuel bonding, superalloys, and superconductors; **Robert W. Bower**, professor, University of California—Davis, for inventing the self-aligned, gate ion-implanted metal-oxide semiconductor field-effect transistor and for establishing ion implantation to fabricate semiconductor integrated circuits; **John F. Brady**, professor, California Institute of Technology, for work in elucidating the basic mechanics of and developing methods for the simulation of multiphase flows; **David R. Clarke**, professor, University of California—Santa Barbara and MRS member, for research on the role of grain boundary phases and their importance to the engineering of technical ceramics; **Alan H. Epstein**, R.C. Maclaurin Professor, Massachusetts Institute of Technology—Cambridge, for time-resolved flow and heat transfer measurements in turbomechanics, and for conception and development of smart engines and micro-engines; **Richard J. Fruehan**, U.S. Steel Professor, Carnegie Mellon University, for research in iron and steel making; **Haren S. Gandhi**, Ford Technical Fellow and manager, Ford Motor Co., Dearborn, for contributions to the research and development of automotive catalysts; **Salim M. Ibrahim**, consultant, Geneva, for advances in elastified fiber technology; **Sungho Jin**, supervisor, Bell Laboratories, Lucent Technologies and MRS member, for research on new magnetic materials and high-temperature superconductors; **William L. Johnson**, Ruben and Donna Mettler Professor of Materials Science, California Institute of Technology and MRS member, for the development of bulk metallic glasses as structural materials; **Howard S. Jones, Jr.**, retired chief of microwave research, U.S. Department of the Army, for the invention and development of antennas and microwave components for missiles and spacecraft; **Hossein Kazemi**, manager, Marathon Oil Co., Littleton, Colo., for contributions to understanding multiphase flow in fractured porous systems, and for developing techniques to manage complex petroleum reservoirs; **Glenn F. Knoll**, professor, University of Michigan—Ann Arbor, for contributions and technical leadership in the field of ionizing radiation detection and application; **U. Fred Kocks**, professor, Los Alamos National Laboratory, for advancements in the theory of strength, kinetics of plasticity of metals, and texture analysis; **Michael R. Ladisch**, professor, Purdue

**Vacuum Pump
Vibration Isolators**

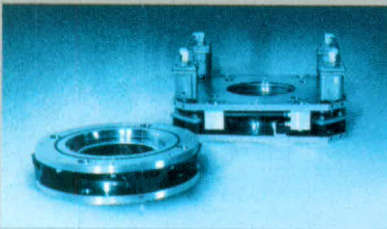

NEC Vibration Isolators effectively remove vibration from turbo and cryo pumps.

Model VI-1 is elastomer isolated; Model VI-2 is air-isolated. Both are UHV compatible, have short insertion lengths and high conductance with a wide variety of flanges available.

Contact NEC:

WEB SITE: <http://www.pelletron.com>
E-MAIL: nec@pelletron.com

**National
Electrostatics
Corp.**

7540 Graber Road, P.O. Box 620310,
Middleton, WI 53562-0310 U.S.A.
Tel. 608/831-7600 • Fax: 256-4103

Circle No. 8 on Reader Service Card.

University, for developing and scaling-up new approaches and materials for process chromatography, absorptive bioseparations, and biocatalysis; **Paul A. Libby**, professor, University of California—San Diego, for contributions as a researcher, author, and educator who advanced knowledge of fluid dynamics, turbulence, and combustion through theoretical analyses; **Kuo-Nan Liou**, professor and director, Institute of Radiation and Remote Sensing, University of California—Los Angeles, for contributions in the theories of radiation transfer and light scattering, with applications to remote sensing technology and climate modeling; **J. David Lowell**, principal, Lowell Mineral Exploration, Rio Rico, Ariz., for demonstrating relationships among geologic systems, metallogenic provinces, and hidden ore deposits; **Nicky C. Lu**, founder and president, Etron Technology Inc., Hsinchu, Taiwan, for contributions to high-speed dynamic memory chip design and cell array technology, and sustained technical leadership in the very large-scale integration/memory industry; **Richard G. Luthy**, Thomas Lord Professor of Environmental Engineering, Carnegie Mellon University, for leadership in the treatment of industrial waste waters, contaminated soils, and aquifers; **James J. Markowsky**, executive vice president, power generation, American Electric Power Service Corp., Columbus, for development and deployment of high-efficiency, low-emissions coal technologies including pressurized, fluidized bed plants; **Marshall I. Nathan**, professor, University of Minnesota—Minneapolis and MRS member, for contributions to semiconductor lasers; **John S. Newman**, professor, University of California—Berkeley, for contributions to applied electrochemistry and for their reduction to practice through advances in electrochemical engineering; **Donald W. Peaceman**, consultant, Houston, for contributions to the development and usage of transient three-dimensional multiphase simulators for predicting performance of petroleum reservoirs; **William T. Plummer**, director, Polaroid Corp., for contributions to optical science and engineering, and for leadership in high-volume manufacturing of precision optics; **Gary A. Pope**, Texaco Centennial Chair in Petroleum Engineering and director, Center for Petroleum and Geosystems Engineering, University of Texas—Austin, for contributions to understanding multiphase flow and transport in porous media, and applications of these principles to improved oil recovery and aquifer remediation; **Freeman D. Shepherd**, retired senior scientist, U.S. Department of the Air Force, for contributions to metal-silicide devices

and infrared cameras; **Peter G. Simpkins**, distinguished member of the technical staff, Bell Laboratories, Lucent Technologies, for contributions to the understanding and development of processes fundamental to the manufacture of low-loss, high-strength optical fiber; **Katepalli R. Sreenivasan**, Harold W. Cheel Professor of Mechanical Engineering, Yale University, for the application of modern nonlinear dynamics to turbulent flows; **Rangaswamy Srinivasan**, president, UV Tech Associates,

Ossining, N.Y., for ultraviolet laser processing of polymers and its extension to refractive surgery of the cornea; **Frank E. Talke**, professor, University of California—San Diego, for work in tribology and mechanics of magnetic storage systems, ink jet technology, and interferometric instrumentation, and for bridging industrial and academic research; and **Leo Young**, consultant, Bethesda, Md., for contributions to microwave technology and to the management of national security research.

Spin-On Solution for Transparent Conductive Coating from Sol-Gel Nanotechnology

- Low Cost
- Antireflection & Antiglare
- Low Sheet Resistance
- High Coating Yield



Cost Effective Portable Spin Coater



Two-Stage Spinning
Dispense liquid during stage 1; spin-up and flatter during Stage 2

Adjustable Speed
Stage 1: 500 - 2,500 rpm
2 - 18 second
Stage 2: 1,000 - 8,000 rpm
3 - 60 seconds



CHEMAT TECHNOLOGY, INC.
9036 Winnetka Avenue, Northridge, CA 91324, USA
(818)727-9786, Fax: (818)727-9477
Home Page: www.chemat.com, e-mail: chemat@aol.com

Circle No. 4 on Reader Service Card.

Among the NAE Foreign Associates are **Ghislain de Marsily**, professor, Université Pierre et Marie Curie, Paris, for leadership in advancing the science and engineering of hydrogeology, especially in contaminant transport and nuclear waste isolation; **Julia S. Higgins**, professor, Imperial College, London, for application of neutron scattering and reflectivity to polymeric materials, and for service to the scientific community; and **Tsuneo Nakahara**, vice chair, Sumitomo Electric Industries Ltd., Osaka, Japan, for contri-

butions and leadership in the development and industrialization of materials for optical communications.

NICE³ Awards Presented to Six Industries to Further Energy-Efficient Technologies

Six U.S. manufacturing companies have received awards totaling \$2.1 million as part of the National Industrial Competitiveness through Energy, Environment, and Economics (NICE³) program, a

strategic partnership between state energy, economic development and environmental departments, industry, and the federal Energy Department to help demonstrate and commercialize energy-efficient and environmentally friendly industrial technologies. The technologies supported by these grants will further advance their application in the chemicals, metalcasting, aluminum, forest products, and steel industries. Award recipients will contribute over \$3 million.

Companies, state partners, and projects for 1999 are **MBA Polymers Inc.**, Richmond, Calif., with the California Energy Commission, to demonstrate a process that allows plastics of similar densities to be separated for reuse; **North American Die Casting Association**, Rosemont, Ill., with the Illinois Department of Commerce and Community Affairs, to demonstrate a two-step process whereby water is applied to a die until it is cool enough for a lubricant to adhere; **Alcoa**, Warrick, Ind., with the Indiana Department of Commerce, Energy Policy Division, to demonstrate a novel coating to protect metal recuperators from corrosive flue gases containing chlorine, potassium, and sodium, saving up to 30% in energy consumption; **Industrial Microwave Systems Inc.**, Research Triangle Park, N.C., with the North Carolina Department of Environment and Natural Resource, to demonstrate the use of microwave technology to dry materials such as paper and textiles; **Air Products and Chemicals Inc.**, Allentown, Pa., with the Ohio Department of Development's Office of Energy Efficiency, to construct the first commercial-scale demonstration of a new technology that uses extreme cold to freeze, separate, and reclaim sands used in metalcasting; and **Weirton Steel Corporation**, Weirton, W. Va., with the West Virginia Energy Efficiency Program, to demonstrate an edge heater that is located prior to the finish-rolling step in hot strip mill technology. □

"But still try—for who knows what is possible?"

— Michael Faraday

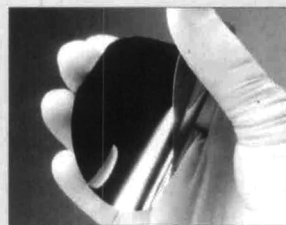

10-MICRON THICK SILICON WAFER

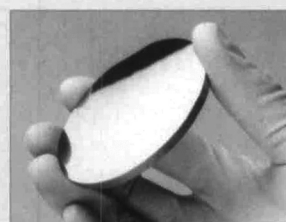

4000-MICRON THICK SILICON WAFER

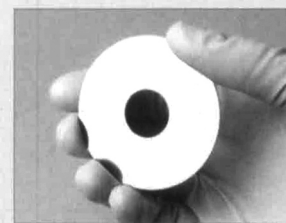

MICROMACHINED SILICON WAFER

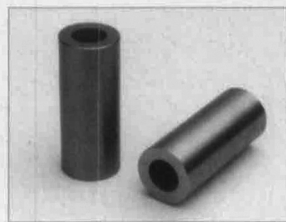

MICROMACHINED SILICON TUBES

The ubiquitous nature of single crystal silicon provides for application possibilities which go far beyond those defined by the "traditional" microelectronics industry. Virginia Semiconductor, Inc. considers silicon to be an **ENGINEERED MATERIAL** ideal for a host of applications that call for

- fatigue and chemical resistance
- machinability
- mechanical robustness
- thermal stability
- and electrical conductivity.

When it comes to preparing engineered silicon products, we have frequently stated (with tongue in cheek), "if we can't make it, you don't need it!"

In the final analysis, we are most eager to **IMAGINE**, to be **CHALLENGED**, and to **TRY**. At Virginia Semiconductor, Inc., we think of the possibilities—not the limitations. Those who know us now expect nothing less; why shouldn't it be that way in our service to you?



Virginia Semiconductor Inc.
1501 Powhatan Street
Fredericksburg, VA 22401
Phone: (540) 373-2900 Fax: (540) 371-0371

SEND LETTERS TO THE EDITOR TO:

Editor, *MRS Bulletin*
Materials Research Society
506 Keystone Drive
Warrendale, PA 15086-7573
Fax 724-779-8313
E-mail Bulletin@mrs.org

Letters must include your full name, institution, address, phone number, and e-mail if available.

Circle No. 12 on Reader Service Card.