

# Visualizing and analysing data-driven shift from decentralized to centralized automotive E/E architectures

Tejas Pravin Phadnis <sup>1,2,✉</sup>, Nils Feyerabend <sup>2</sup> and Joachim Axmann <sup>1</sup>

<sup>1</sup> Technische Universität Braunschweig, Germany, <sup>2</sup> Volkswagen Aktiengesellschaft, Germany

✉ tejas.phadnis@volkswagen.de

## Abstract

Decentralized E/E architectures (EEAs) are facing challenges and bottlenecks in implementing new features and technologies. The shift towards centralized EEAs has many challenges and needs to be handled pragmatically by considering concurrency with the existing EEAs. To address the challenges of architectural shift, the paper showcases the quantitative comparison of EEAs and visualizes the flow of shifting sub-function and hardware blocks using the Sankey diagram. The observations from the diagram as a result will support OEMs to analyse and take decisions on the shift while developing EEAs.

*Keywords: visualisation, architectural design, data analysis, future trends, design knowledge*

## 1. Introduction

Over a long period, the automotive industry has been dominated by the development of mechanical components. Later, the value provided by electronics has been perceived by numerous automotive electronic control units (ECUs) (Navet & Simonot-Lion, 2017). Further technological advancements in electronics act as a catalyst for ongoing automotive transformation to software-driven vehicles (SDV) (Zerfowski & Lock, 2019). Besides transportation, SDVs promise performance, safety, security, entertainment, comfort, over-the-air (OTA) functional updates, integration with surroundings, and many more functionalities up to autonomous driving (Benckendorff et al., 2019). Customers always demand ever-increasing innovative features inside the vehicle. OEMs are continuously aiming to enhance the user experience and implement various functionalities using new technologies to stand out from the competition. The megatrends like electrification, automation, connectivity, digitalization, and robotics leap into automotive development. Each trend has an impact on underlying electric and electronic architecture (EEA) in different ways (Navale et al., 2015). The number of electric and electronic (EE) components and functions increased dramatically and has pushed software to the forefront. Currently, EEA contains 50-150 ECUs, hundreds of sensors and actuators interconnected to each other, and executes more than 100 million lines of code by transmitting thousands of signals with automotive communication networks. Furthermore, the size of EEA is expected to grow by 7% per year (Bucher et al., 2017; Apostu et al., 2019; Placho et al., 2020). Consequently, the complexity of EEA rises significantly with the usage of a large number of components, data-driven interconnections, and their dependencies with each other and surroundings (Jiang, 2019). Automotive EEA serves as the backbone of the EE system development and influences the way of handling complexity. The decisions of EEA design and implementation are critical to accommodate development trends, function enhancement, as well as future requirements and needs (Jiang, 2019).

Traditionally, EEA is highly decentralized in which often a single customer function is realized by multiple ECUs interconnected via the same or different automotive bus communications.

Implementation of several functions leads to the addition of more ECUs, where each ECU is capable of processing its data and communicating with other ECUs. It not only increases the load on the communication network but also makes wiring harnesses bulky. Today's decentralized EEAs are facing bottlenecks in realizing promises of SDVs. It has limitations in incorporating upcoming technical demands and faces multiple challenges regarding new methodologies to handle the increasing volume of data and their interdependencies (Kanajan et al., 2006; Navale et al., 2015; Zhu et al., 2021). Therefore, decentralized EEA is evolving and going through a paradigm shift towards centralized EEA such as centralized domain-oriented, cross-domain-oriented, and vehicle-centralized with geometric zone-orientation architectures (Benckendorff et al., 2019; Bandur et al., 2021). Centralized EEAs are characterized by domain controllers with an Ethernet as a communication network. These domain controllers optimize function allocation and centralize the processing of functions at individual domain levels within a vehicle (Navale et al., 2015; Zhu et al., 2021). This evolution facilitates vehicles such as SDV or software-on-wheel and also embraces the EEA to become a "communication-control-computation" platform (Zhu et al., 2021).

European OEMs are developing multiple EEAs simultaneously to build different vehicle projects based on technical platforms, customer segments, and international markets. OEMs are parallelly maintaining decentralized as well as developing centralized EEAs. These EEAs are intrinsically linked to the application logic over time and confront multiple challenges during the shift. During this transition, OEMs have to keep the balance between various aspects such as technical and non-technical challenges, cost, development time, internal competence, supplier cooperation, and transition benefits. The architectural shift is not easy and requires significant efforts and resources. Further, OEMs have a long history of legacy solutions, which also need to be enhanced, modified, and integrated into new EEAs. In such a shift leveraging is also a challenge. The shift towards centralized EEAs must be pragmatic by considering existing decentralized EEAs. Hence, OEMs eventually add, remove, and modify different artifacts i.e. components of the EEA model to optimize different aspects of EEA. To overcome the challenges of the shift, it is advantageous to have an overview of the artifacts during the shift from one EEA to another. Such an overview is necessary to understand, analyse as well as validate the purpose of shift concerning the design and development of EEAs. To make it manageable, and controllable, this paper aims to showcase the shift using architectural data. The contribution of this paper addresses three folds. In particular it

- provide the comparison of decentralized and centralized architectural data on an abstract level using a set theory and reusability aspect
- visualize the shift from decentralized to centralized EEAs using functions and hardware
- interpret observations of visualisation to validate the purpose of architectural shift

## 2. Related work

EEA plays a crucial role in the design, development, testing, and integration of automotive systems (Otten et al., 2019). Each type of EEA has several advantages and disadvantages. Every architectural type involves distinct information and artifact aggregation. The evolutionary historical map is illustrated in (Figure 1). Traditional decentralized EEA mostly follows the separation of ECUs among the functions. Single or very few functions are deployed and realized on a single ECU. It helps OEMs to distribute the development to several suppliers and makes integration and verification easy. On one side, it provides the flexibility to replace the failed ECUs in the EE system, and on the other, increases the cost because of the large number of ECUs and their wiring harnesses (Reinhardt & Kucera, 2013). The network communication used in decentralized EEA is insufficient for handling large amounts of data from sensors like cameras. It acts as one of the drivers for the consolidation of the centralized EEA (Bandur et al., 2021). More parameters such as limited bandwidth, low deterministic latency, harness complexity, less scalability, and increasing dynamic configuration requirements create bottlenecks for decentralized EEAs (Zhu et al., 2021). These necessitate the development of centralized EEA by consolidating the various functionalities on ECUs such as domain-specific and zone-controller ECUs. In these architectures, functions are categorized according to the domains and can be developed in a sophisticated manner using fewer communication interfaces and dependencies on multiple ECUs. Zone

ECUs are capable of managing the functions that happen at their physical location irrespective of their domains. These domain controllers are processing large amounts of data and are connected to high-speed communication such as Flat Panel Display (FPD-Link) or Gigabit Multimedia Serial Link (GMSL) and networks like Ethernet. These architectures consequently lead to a reduction in the number of ECUs, as well as the length and weight of wiring harnesses (Reinhardt & Kucera, 2013; Jiang, 2019).

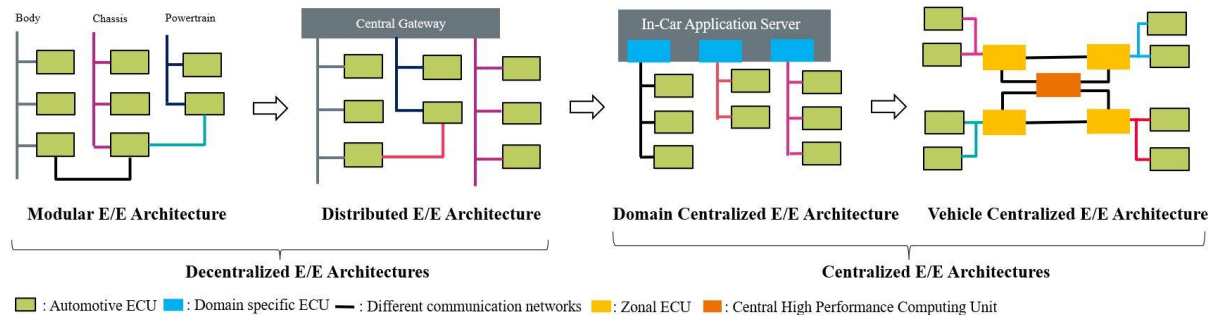

**Figure 1. Overview of decentralized and centralized E/E architectures**

Many OEMs are realizing the benefits of centralized architectures and are moving gradually toward it. There is no standard universal EEA. Each OEM is trying to create an intelligent EEA such as E3 (Volkswagen), E platform 3.0 architecture (BYD), FACE - Future Architecture for Computing Element (Renault), and new generation architectures (Tesla) often in combination with different high-performance central computing units such as In Car Application Server (ICAS) (Volkswagen) and SPA2 (Volvo) (ReportLinker, 2021, Tany et al., 2022). With automotive, the avionic systems are also shifting to centralized EEAs (Tagawa & Souza, 2011). Managing the changing requirements, and handling of large EE data and their complexity is overwhelming and ambiguous during the development. Hence, multiple analysis methods are required to help in decision-making for design and development. The structural and logical comparison methods are illustrated to support the evaluation, adaptation, and enhancement of the EEA. These approaches are used to evaluate the architectural designs (Kanajan et al., 2006; Popp et al., 2007; Lisova et al., 2022; Schindewolf et al., 2022). (Ghosal et al., 2010) described the architectural design comparison methods with a focus on the architectural commonalities and differences, structural strengths and weaknesses, and trade-off parameters for achieving functional and non-functional properties. These are based on the evaluation criteria and help to decide the most suitable structure for the specific system implementation. However, data analysis during the shift of EEAs and visualisation of architectural data flow need to be supported. It will help to analyse the implementation of functions on the underneath EEA and validate the development.

Reusability is one of the key decision making factor during the development. (Papamichail et al., 2019; Mehboob et al., 2021) explained reusability as a characteristic of the quality using attributes like generality, cohesion, coupling, portability, maintainability, and ease of modification. The measurement of these attributes is determined using matrices along with their weighing parameter. In our paper, reusability is quantitatively described with its applications during the architectural shift. In general, the accessibility and readability of analysis results are improved by matrix-based and graphic-based visualization techniques. (Kanajan et al., 2006; Popp et al., 2007; Ghosal et al., 2010; Shahin et al., 2014; Eder, 2022). One of the graphical techniques, Sankey diagram, is widely used for showcasing data flow in fields like election polls, material flow during mechanical processes, medical research, visualizing industrial metabolism, industrial ecology, literature review. We have used in the EEA field to visualize the data driven architectural shift.

### 3. E/E architecture: System model

A “system is a collection of components organized to accomplish a specific function or set of functions” (IEEE, 2000). When a system, “embodied in its components, their relationships to each other, and to the environment, and the principles guiding its design and evolution is called as an architecture” (IEEE, 2000). By extending this definition to the automotive EE context, EEA is defined as the fundamental organization of a vehicle's EE components comprising of ECUs, sensors, actuators, wiring, power

distribution, and network communication to achieve the desired functions and performance objectives. This definition places significant emphasis on understanding the interactions and interrelationships among these components and their relation with the environment (Jiang, 2019). EEA is a complex system that adheres to guiding principles for design and integration and has aspects of evolution over time. The terminologies of the EEA used in the scope of this paper are based on the PREEvision model from the company Vector (PREEvision, 2010). The PREEvision provides a framework to represent and design structures using various artifacts and their mappings. Our EEA system model ( $\mathbb{E}$ ) is divided into 3 main layers namely the logical-functional layer, software layer, and hardware layer shown in the (Figure 2).

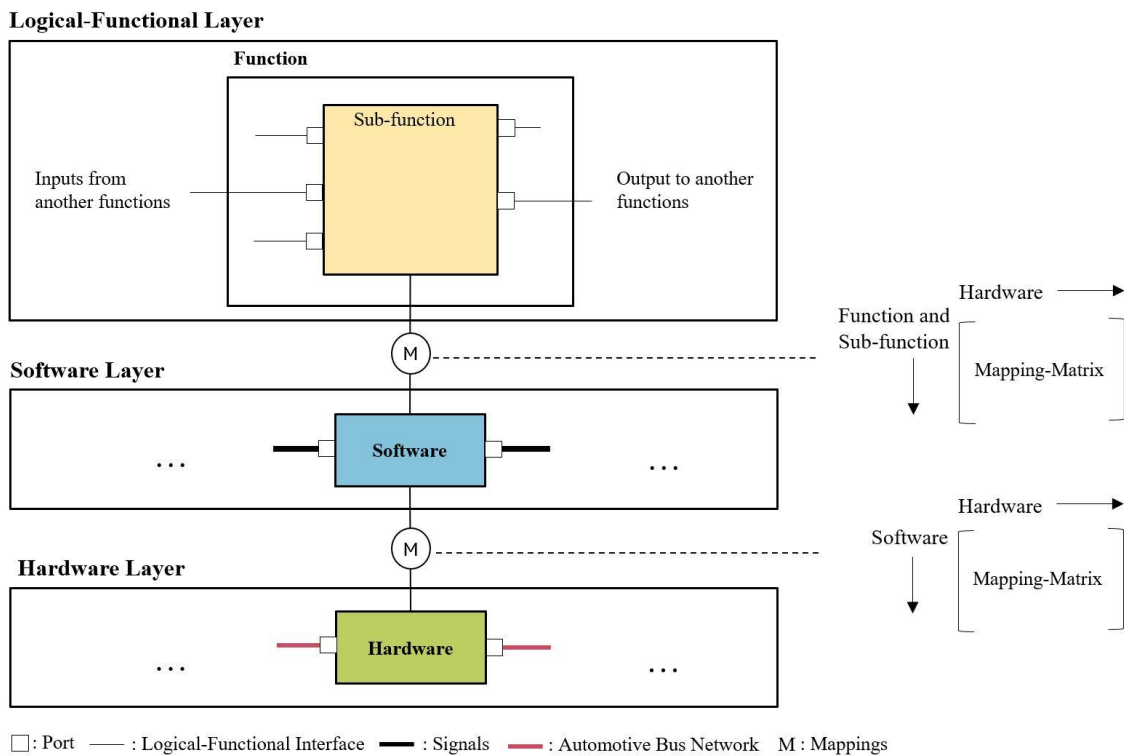

**Figure 2. Model of E/E architecture layers**

The logical-functional level consists of a chain of functions having interactions and interrelations to ensure the desired behaviour of the system, sub-system or overall applications of the vehicle. The individual function (F) describes the behaviour which is derived from the overall requirements. It consists of a set of sub-functions (SF) such as logical sensor, actor, Human-Machine Interface (HMI) and controller blocks connected internally as well as externally with other functions. These sub-functions are mapped to software (SW) blocks, where the logic is implemented. The software blocks are further allocated to hardware (HW) blocks i.e. ECUs where these are realized. Data exchanges between software blocks are possible via signals, whereas hardware blocks are connected via various communication networks such as Controller Area Network (CAN), Local Interconnect Network (LIN) and Ethernet. These hardware are positioned at various locations inside the vehicle determined by geometric topology (PREEvision, 2010; Vector Group, 2010). The dependencies across layers are symbolized using mappings matrices.

#### 4. Comparison of E/E architectures using set theory

Volkswagen has already existing decentralized EEA “Modulare Querbaukasten” or Modular Transverse Toolkit (MQB) and ongoing “Modularer E-Antriebsbaukasten” or modular electric drive (MEB) as centralized EEA (Press release, 2022) are considered for the reference scenarios in this paper. The architectural system model with logical-functional, software and hardware layers discussed earlier in (sec. 3) using (Figure 2) is independent of the architectural type. The types of artifacts on intra- and

inter-layers remain the same and vary quantitatively and qualitatively. The artifacts of our architectural system model are described as follows.

- Architectural model  $\mathbb{E}_D = \{F_D, SW_D, HW_D\}$  &  $\mathbb{E}_C = \{F_C, SW_C, HW_C\}$  where  $D \in$  decentralized EEA &  $C \in$  centralized EEA
- logical-functional layer  $F_D = \{F_{D1}, F_{D2}, F_{D3}, \dots, F_{Dl}\}$  &  $F_C = \{F_{C1}, F_{C2}, F_{C3}, \dots, F_{Cl}\}$  where  $(Dl = Cl) \vee (Dl \neq Cl)$
- logical-function  $F_{Di} = \{SF_{D1}, SF_{D2}, \dots, SF_{Dp}\}$  &  $F_{Ci} = \{SF_{C1}, SF_{C2}, \dots, SF_{Cp}\}$  where  $Di \in F_D$  &  $Ci \in F_C$
- Software layer  $SW_D = \{SW_{D1}, SW_{D2}, SW_{D3}, \dots, SW_{Dm}\}$  &  $SW_C = \{SW_{C1}, SW_{C2}, SW_{C3}, \dots, SW_{Cm}\}$  where  $(Dm = Cm) \vee (Dm \neq Cm)$
- Hardware layer  $HW_D = \{HW_{D1}, HW_{D2}, HW_{D3}, \dots, HW_{Dn}\}$  &  $HW_C = \{HW_{C1}, HW_{C2}, HW_{C3}, \dots, HW_{Cn}\}$  where  $(Dn = Cn) \vee (Dn \neq Cn)$

where  $(\forall F_D, \forall SW_D, \forall HW_D) \in \mathbb{E}_D$  &  $(\forall F_C, \forall SW_C, \forall HW_C) \in \mathbb{E}_C$  and  $Dl, Cl, Dm, Cm, Dn, Cn$  are maximum number of logical-function, software and hardware blocks present in decentralized and centralized EEA model respectively.

The task of comparing the two EEAs consists of determining similarities and differences quantitatively. We have used the set theory which is represented graphically in (Figure 3). The intersection area represents the common artifacts between these two EEAs, and calculated as  $(\mathbb{E}_D \cap \mathbb{E}_C)$ . We can use this term for all layers as  $(F_D \cap F_C)$ ,  $(SW_D \cap SW_C)$ ,  $(HW_D \cap HW_C)$ . The remaining area represents the differences i.e. artifacts specifically present only in a type of EEA and these are not being reused in the next EEA.

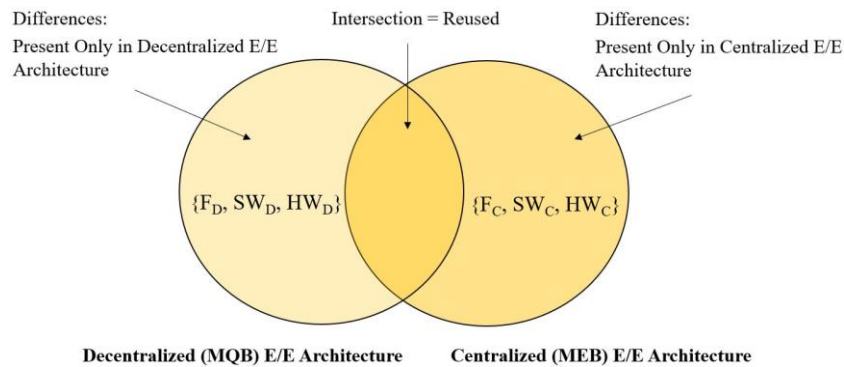

**Figure 3. Intersection of decentralized and centralized E/E architectures**

Consider the implementation example of a braking system in both types of EEAs. While shifting from decentralized to centralized EEA, the regenerative braking functionality is added to the system (Volkswagen, 2022). When a vehicle is slowing down electric motor acts as a generator and sends energy back to the battery. Therefore, the function is partly reused and upgraded with additional features. Similarly, many functions, software, and hardware are added, removed, and modified during the shift. OEMs are aiming to achieve the synergies between different architectural artifacts to reduce the development efforts and time. Hence, the inclusion of the similarity measure or reusability plays an important role. The similarity measure (Sim) is calculated by the Jaccard coefficient. It is expressed as the ratio of the intersection of two EEAs and the union of two EEAs, shown in (Equation 1). This Jaccard coefficient can be further used on individual layers of EEA to calculate similarities.

$$Sim(\mathbb{E}_D, \mathbb{E}_C) = \frac{|\mathbb{E}_D \cap \mathbb{E}_C|}{|\mathbb{E}_D \cup \mathbb{E}_C|} \quad (1)$$

This comparison aspect provides an overview of the commonality and differences quantitatively. A higher similarity coefficient expresses the more reusability of artifacts between two EEAs. We extend the use of the Jaccard coefficient to determine the reusability of different layers of EEA. While developing centralized EEA from decentralized EEA, a few sub-function blocks are being carried forward and reallocated to same or different hardware shown in (Figure 5). The quantitative aspect of the reusability of sub-function blocks is represented as

$$Reusability(\%) = \frac{\text{Number of common SF}}{\text{Total number of SF in both architectures}} * 100 \quad (2)$$



This reusability aspect acts as one of the input information to estimate development time, cost, efforts, and time to market. Further, it oversees the development to identify the fulfilment parameter for the reuse functions on ECUs. Reuse leads to a reduction in homologation efforts for the release.

## 5. Comparison of E/E architectures using Sankey diagram

The sub-function and hardware blocks inside respective layers are considered to reveal the data flow between two EEAs during the shift. By referring to (Figure 2), sub-function blocks are mapped to software and further to hardware blocks. Therefore, using traceability and transitive property, a perspective of mapping and relations between functions and sub-functions with the hardware is generated and shown in (Figure 4). The mappings have two conditions, one sub-function block must be mapped to only one hardware block and one or more sub-function blocks from the same or different functions can be mapped to the same hardware block. Hence, a hardware can realize multiple sub-function blocks. (Figure 4) shows the example of function 1 with four sub-function blocks mapped to four different hardware blocks.

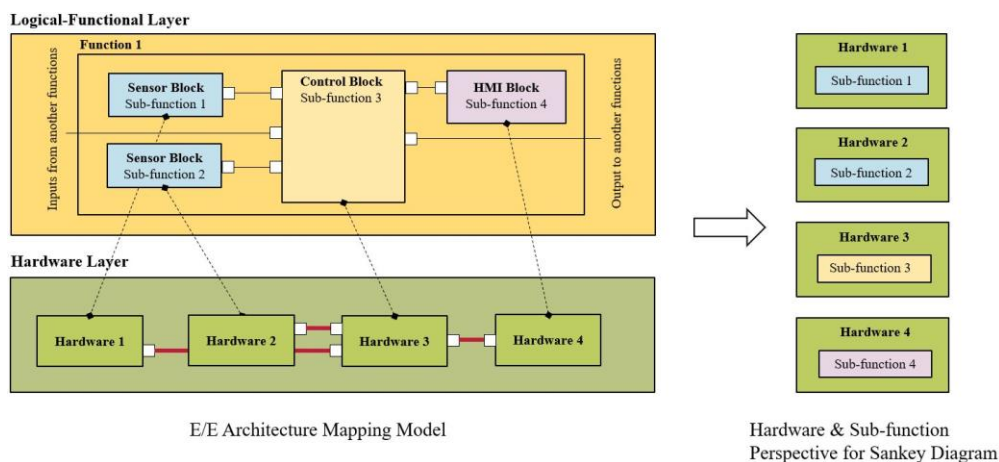

**Figure 4. Example of mappings between function, sub-function with hardware blocks**

The collection of such grouping between hardware and sub-functions is performed on MQB and MEB architectural data. We have developed the Python application for the implementation and visualization of this architectural shift. The example Sankey diagram and the observations as a result are shown in the next section.

## 6. Observations of Sankey diagram

The detailed view of sub-function and hardware blocks helps to analyse and visualize the patterns of addition, removal, and modification while shifting from one EEA to another. Some of the observations from (Figure 5) are

- New addition of hardware namely  $HW_{C2}$  and  $HW_{C3}$  in the centralized EEA.
- Removal of hardware namely  $HW_{D2}$ ,  $HW_{D3}$  and  $HW_{D4}$  while developing centralized EEA.
- Though  $HW_{D2}$  and  $HW_{D4}$  are removed but some of their sub-function blocks are reused and reallocated to other hardware as  $HW_{C2}$  and  $HW_{C3}$
- $HW_{C2}$  realized a large number of control blocks which are distributed on different hardware in decentralized EEA and similarly HMI blocks are consolidated to  $HW_{C3}$  in centralized EEA

The EEA size is large where, each EEA contains more than 500 functions, 5000 sub-function, 250 software, and 100 hardware blocks. To visualize large data and to improve the readability, Sankey diagram with hardware perspective is implemented where reallocation of sub-function blocks are quantitatively indicated by thickness of changeover connections in (Figure 6). The addition, removal, and carry forward of sub-functional blocks from decentralized to centralized EEA are observed. By using the real large data set mainly the convergence and divergence patterns of sub-functions over hardware blocks are observed.

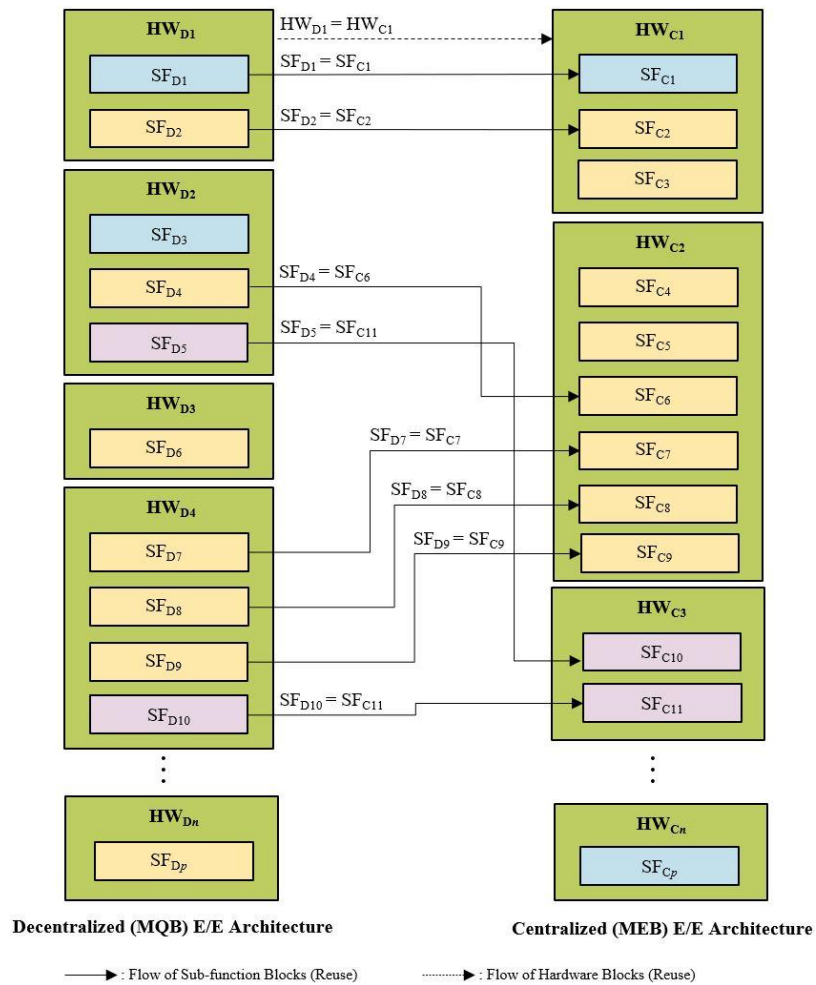

Figure 5. Example Sankey diagram with sub-function and hardware blocks

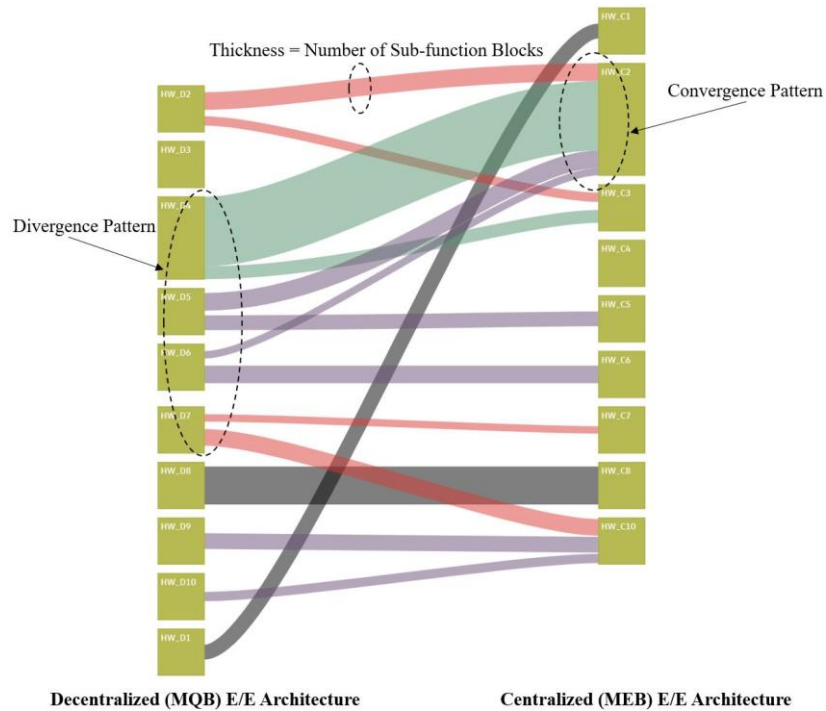

Figure 6. Part of Sankey diagram with hardware blocks on real data

Convergence means the sub-functional blocks are coming together in one hardware block of centralized EEA from different hardware blocks of decentralized EEA. Divergence shows the splitting of sub-functional blocks from one hardware block of decentralized EEA to different hardware block of centralized EEA. Such observations from (Figure 5 and Figure 6) ignite discussion, interpretation and analysis to understand the reasons behind such patterns in detail leading to effective decision-making. The technological trends affecting the development of centralized EEA can also be traced using such Sankey diagrams.

## 6.1. Interpretation of observed patterns

### 6.1.1. *Observation 1: convergence pattern on specific function, sub-function, and hardware blocks*

One of the reasons for the convergence pattern is technological advancement bringing together previously distributed technologies. There are many examples of technological advancements in other sectors using software like smartphones, laptops, and smart home functions where functionalities converge to replace multiple devices into one. In our case, these are various functions and hardware components. The convergence of functions on centralized hardware fuels the birth of new features. Communication and sensing technologies are transforming Advanced Driving Assistant System (ADAS) functionalities. New sensors like high-range nano radar and cameras led to the surge of features like object detection, lane assistance, and blind spot detection in the new EEA. Therefore, the patterns of convergence and consolidation of hardware are observed during the development of centralized EEA. Sometimes it is difficult to modify and upgrade functions in the existing decentralized EEA because of dependencies, interactions and physical interconnections with each other. Functions like ADAS include the technologies that assist drivers with safety features, lane assistance of the vehicle and also enable the various levels of autonomous driving. One of the system requirements is to access the data from various sensors and process it with high computing power in a faster manner. It is difficult to accomplish in a decentralized EEA as it requires central decision making. Another reason for convergence is the influence of the supplier strategy. The development of the functions distributed over multiple hardware requires extensive communication between OEM and multiple suppliers developing the ECUs is a costly overhead. Therefore, such factors drive the pattern of convergence during the shift.

### 6.1.2. *Observation 2: divergence pattern on specific functions and hardware blocks*

In decentralized EEA, most sub-function blocks have been implanted individually on hardware blocks having limited memory. Domain controllers in centralized EEA have high computing power and act as a central data hub inside the vehicle. Hence during the development, many control sub-function blocks from different hardware blocks of decentralized EEA are reallocated to the domain controller of the centralized EEA, and sub-function blocks like sensor, actuator, and HMI remain on the same hardware block. In decentralised EEA, enhancing cross-domain functionality impacts large number of hardware, and even additional hardware blocks are required. In a centralised EEA, the impact is on the domain controller with high performance, higher usage of an existing core, memory or network. Furthermore, a single software release for the central controller is adequate to enhance the cross-domain functionality. Similarly, the centralized approach is beneficial for software testing, integration, and releases by focused attention and lowered coordination with suppliers. Therefore, a divergence pattern in such cases is observed and it is beneficial for development and reduces the possible proliferation of the hardware.

### 6.1.3. *Observation 3: specific hardware blocks are highly affected*

In the Sankey diagram on real architectural data, it is observed that there is a large movement of sub-functional blocks from decentralized EEA onto the specific hardware blocks of centralized EEA. These specifically relate to infotainment and body control domain controllers due to the fact that OEMs are implementing functionalities that combine information, comfort, connectivity, and driving assistance. Similarly, hardware blocks in centralized EEA are also affected by the new regulations and standards concerning safety and security and UNECE regulations.



## 7. Conclusion and future work

Driven by megatrends, the vehicle is expected to be SDVs connected with the environment and undergo profound changes in current EE systems. Innovation and adaptation of continuous changes are essential for the EEA to stay abreast of evolving automotive technologies. In the first part of the paper, the bottleneck factors for the traditional decentralized EEAs are discussed. OEMs are moving away from single-function ECUs towards consolidation with domain-specific controllers in centralized EEAs. In complex decentralized EEAs having concurrent legacy systems to be maintained, a shift to a centralised EEA requires a systemic analytical approach. The Sankey diagram is used as a visualization technique to analyse shift using architectural data. Analysis patterns observed in the Sankey diagram as results, are used for the interpretation and validation of the shift. It helps to support the architectural design decisions of OEMs throughout the development. As future work, there are ways to expand on the methods for effort analysis during architectural shift. Advanced tools and libraries can be used to enhance the visualization aspect. More artifacts of EEA like signals that carry sensor and actuator data on automotive bus communication can be included in the Sankey diagram which will help in analysing the shift without losing any communication data.

## Acknowledgement

The results, opinions and conclusions expressed in this paper are not necessarily those of Volkswagen Aktiengesellschaft.

## References

- Apostu, S., Burkacky, O., Deichmann, J. and Doll, G. (2019), “Automotive Software and electrical/electronic architecture: Implications for oems”, McKinsey & Company, McKinsey & Company, available at: <https://www.mckinsey.com/industries/automotive-and-assembly/our-insights/automotive-software-and-electrical-electronic-architecture-implications-for-oems> (accessed 13 November 2023).
- Bandur, V., Selim, G., Pantelic, V. and Lawford, M. (2021), “Making the case for centralized automotive E/E Architectures”, *IEEE Transactions on Vehicular Technology*, Vol. 70, No. 2, pp. 1230–1245. <https://doi.org/10.1109/tvt.2021.3054934>
- Benckendorff, T., Lapp, A., Oexner, T. and Thiel, T. (2019) ‘Comparing current and future E/E architecture trends of commercial vehicles and passenger cars’, *Proceedings of the 19. Internationales Stuttgarter Symposium; Stuttgart, Germany, May 25, 2019; Springer Vieweg, Wiesbaden*, pp. 1190–1200. [https://doi.org/10.1007/978-3-658-25939-6\\_95](https://doi.org/10.1007/978-3-658-25939-6_95)
- Bucher, H., Reichmann, C. and Becker, J. (2017), “An integrated approach enabling cross-domain simulation of model-based E/E-architectures”, *Proceedings of the WCX™ 17: SAE World Congress Experience, United States, March 28, 2017, SAE Technical Paper Series*. <https://doi.org/10.4271/2017-01-0006>
- Eder, J. D. (2022). *Automatic Exploration of Automotive E/E Architectures [PhD Thesis]*, Technische Universität München. <https://mediatum.ub.tum.de/?id=1638880>
- Ghosal, A., Giusto, P., Sinha, P., Osella, M., D’Ambrosio, J. and Zeng, H. (2010), “Metrics for evaluating electronic control system architecture alternatives”, *SAE Technical Paper Series*, vol. 148, pp. 89-98. <http://doi.org/10.4271/2010-01-0453>
- IEEE (2000), *IEEE Std 1471-2000: IEEE Recommended Practice for Architectural Description of Software-Intensive Systems*, in *IEEE Std 1471-2000*. <https://doi.org/10.1109/ieeestd.2000.91944>
- Jiang, S. (2019), “Vehicle E/E architecture and its adaptation to new technical trends”, *Proceeding of the WCX SAE World Congress Experience, United States, April 02, 2019, SAE Technical Paper Series*, pp. 1–10. <https://doi.org/10.4271/2019-01-0862>
- Kanajan, S., Pinello, C., Haibo Zeng and Sangiovanni-Vincentelli, A. (2006), “Exploring trade-off’s between centralized versus decentralized automotive architectures using a virtual integration environment”, *Proceedings of the Design Automation & Test in Europe Conference, Munich, Germany, March 6-10, 2006, IEEE CS Press*, pp. 548-553. <https://doi.org/10.1109/date.2006.243895>
- Lisova, E., Broux, R., Denil, J., Bucaioni, A. and Mubeen, S. (2022), “Communication patterns for evaluating vehicular E/E architectures”, *Proceedings of the 2022 International Conference on Electrical, Computer, Communications and Mechatronics Engineering (ICECCME), Maldives, Maldives, November 16-18, 2022, IEEE*. <http://doi.org/10.1109/iceccme55909.2022.9987747>
- Mehboob, B., Chong, C. Y., Lee, S. P., & Lim, J. M. Y. (2021). “Reusability affecting factors and software metrics for reusability: A systematic literature review”. *Journal of Software: Practice and Experience*, Vol. 51, No. 3, pp. 1416-1458. <https://doi.org/10.1002/spe.2961>

- Navale, V.M., Williams, K., Lagospiris, A., Schaffert, M. and Schweiker, M.-A. (2015), “(r)evolution of E/E architectures”, *SAE International Journal of Passenger Cars - Electronic and Electrical Systems*, Vol. 8 No. 2, pp. 282–288. <https://doi.org/10.4271/2015-01-0196>
- Navet, N. and Simonot-Lion, F. (2017), *Automotive Embedded Systems Handbook*, CRC Press. <https://doi.org/10.1201/9780849380273-4>
- Otten, S., Glock, T., Hohl, C.P. and Sax, E. (2019), “Model-based variant management in Automotive Systems Engineering”, *Proceedings of the 2019 International Symposium on Systems Engineering (ISSE)*, Edinburgh, UK, October 01-03, 2019, IEEE, pp. 1-7. <http://doi.org/10.1109/isse46696.2019.8984593>
- Papamichail, M. D., Diamantopoulos, T., & Symeonidis, A. L. (2019). “Measuring the reusability of software components using static analysis metrics and reuse rate information”. *Journal of Systems and Software*, Vol. 158, p.110423. <https://doi.org/10.1016/j.jss.2019.110423>
- Placho, T., Schmittner, C., Bonitz, A. and Wana, O. (2020), “Management of Automotive Software updates”, *Microprocessors and Microsystems*, Vol. 78, pp. 103257. <https://doi.org/10.1016/j.micpro.2020.103257>
- Popp, P., di Natale, M., Giusto, P., Kanajan, S. and Pinello, C. (2007), “Towards a methodology for the quantitative evaluation of Automotive Architectures”, *Proceedings of the 2007 Design, Automation & Test in Europe Conference & Exhibition Nice, France, April 16-20, 2007*, IEEE. <http://doi.org/10.1109/date.2007.364643>
- PREEvision (2010), *E/E Engineering Environment*. [online] Vector, available at: <https://www.vector.com/int/en/products/products-a-z/software/preevision/#> (accessed 13 November 2023).
- Press release (2022), “Baukastenstrategie als Erfolgsformel: Der MQB Feiert Zehnjähriges Jubiläum”. [online] Volkswagen Newsroom, available at: <https://www.volkswagen-newsroom.com/de/pressemittelungen/baukastenstrategie-als-erfolgsformel-der-mqb-feiert-zehnjahriges-jubilaeum-8030>. (accessed 13 November 2023a).
- Reinhardt, D., and Kucera, M. (2013), “Domain Controlled Architecture- A New Approach for Large Scale Software Integrated Automotive Systems”, *Proceedings of the 3rd International Conference on Pervasive Embedded Computing and Communication Systems - PECCS, 2013*, SciTePress, pp. 221-226. <https://doi.org/10.5220/0004340702210226>
- ReportLinker. (2021). “Intelligent vehicle E/E architecture and Computing Platform Industry Research Report, 2021”. [online] GlobeNewswire News Room. Available at: <https://www.globenewswire.com/news-release/2021/09/01/2289809/0/en/Intelligent-Vehicle-E-E-Architecture-and-Computing-Platform-Industry-Research-Report-2021.html>
- Shahin, M., Liang, P. and Babar, M.A. (2014), “A systematic review of software architecture visualization techniques”, *Journal of Systems and Software*, Vol. 94, pp. 161–185. <https://doi.org/10.1016/j.jss.2014.03.071>
- Schindewolf, M., Stoll, H., Guissouma, H., Puder, A., Sax, E., Vetter, A., Rumez, M., & Henle, J. (2022), “A comparison of architecture paradigms for dynamic reconfigurable automotive networks” *Proceedings of the 2022 International Conference on Connected Vehicle and Expo (ICCVE)*, Lakeland, FL, USA, March 07-09, 2022, IEEE, pp. 1-7. <https://doi.org/10.1109/iccve52871.2022.9742775>
- Tagawa, G.B. and Souza, M.L. (2011), “An overview of the Integrated Modular Avionics (IMA) concept”, *Proceedings of the Brazilian Conference on Dynamics, Control and Applications*, September, 2011, DINCON, pp. 277– 280. <http://doi.org/10.5540/dincon.2011.001.1.0071>
- Tany, N. S., Suresh, S., Sinha, D. N., Shinde, C., Stolojescu-Crisan, C., & Khondoker, R. (2022). “Cybersecurity Comparison of Brain-Based Automotive Electrical and Electronic Architectures”. *Information*, Vol. 13, No. 11, pp. 518. <https://doi.org/10.3390/info13110518>
- Vector Group (2010), *Model-Based Electric/Electronic Development*. [online] Vector, available at: [https://cdn.vector.com/cms/content/products/preevision/docs/PREEvision\\_doc\\_brochure\\_EN.pdf](https://cdn.vector.com/cms/content/products/preevision/docs/PREEvision_doc_brochure_EN.pdf) (accessed 13 November 2023).
- Volkswagen (2022). A tale of two powertrains. [online] Volkswagen Newsroom, available at: <https://www.vw.com/en/newsroom/future-of-mobility/meb-v-mqb.html>. (accessed 12 February 2024).
- Zerfowski, D. and Lock, A. (2019), “Functional architecture and E/E-architecture – a challenge for the automotive industry”, *Proceedings of the 19. Internationales Stuttgarter Symposium*; Stuttgart, Germany, May 25, 2019; Springer Vieweg, Wiesbaden, pp. 909–920. [https://doi.org/10.1007/978-3-658-25939-6\\_70](https://doi.org/10.1007/978-3-658-25939-6_70)
- Zhu, H., Zhou, W., Li, Z., Li, L. and Huang, T. (2021), “Requirements-Driven Automotive Electrical/Electronic Architecture: A Survey and Prospective Trends”, *IEEE Access*, Vol. 9, pp. 100096–100112. <https://doi.org/10.1109/access.2021.3093077>